

OPERATION AND MAINTENANCE MANUAL

SH130B SSB

COD.: MUM0121 REV. 01

english

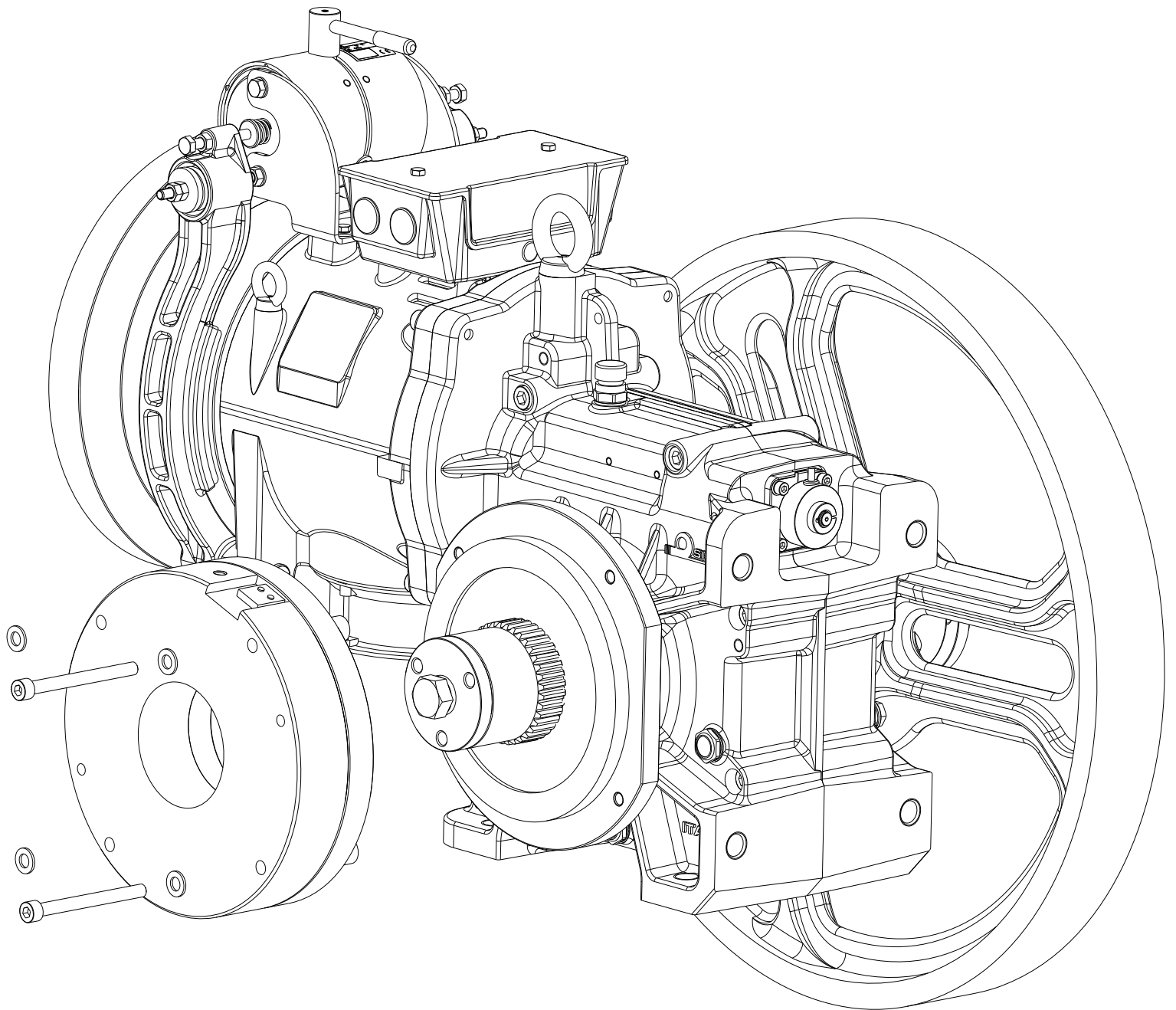

SICOR S.p.A.

Head Office and Production Centre
Viale Caproni 32 (Industrial Area) 38068 Rovereto (TN) Italy
Ph.. +39 0464 484111 Fax +39 0464 484100
www.sicor-spa.it info@sicor-spa.it

INDEX

1.	GENERAL INDICATIONS	2
2.	PROJECT DESCRIPTION	3
2.1.	LIABILITY AND WARRANTY	3
3.	SSB PROJECT	4
3.1.	ELECTROMAGNETIC BRAKE DEVICE	5
3.2.	BRAKE SUPPORT	7
4.	OVERALL DIMENSIONS	10
5.	SSB SUPPLY	11
5.1.	COMPLETE SSB-SH130B KIT	11
5.2.	SSB-SH130B WINCH OPTION	11
5.3.	COMPLETION KIT	11
5.4.	ACCESSORIES	11
6.	INSTALLATION AND MAINTENANCE	12
7.	SAFETY PRECAUTIONS	12
8.	TRANSPORTING AND HANDLING LOADS	13
9.	INSTALLING THE COMPLETE SSB KIT	13
10.	COMPLETION KIT INSTALLATION	16
11.	ELECTRICAL CONNECTIONS	16
11.1.	BRAKE	16
11.2.	MICROSWITCH	17
11.3.	SSB power supply	17
12.	STARTING THE WINCH	18
13.	CHECKS AND MAINTENANCE WORK	19
13.1.	SSB BRAKE AIR-GAP ADJUSTMENT	20
13.2.	SSB BRAKE MICROSWITCH ADJUSTMENT	20
14.	MANUAL EMERGENCY OPERATING	21
14.1.	WARNINGS	21
14.2.	INSTRUCTIONS FOR AN EMERGENCY MANUAL MANOEUVRE	21
15.	ANNEXES	24
15.1.	TÜV CERTIFICATION FOR SH130B WINCH	24

1. GENERAL INDICATIONS

The purpose of this manual is to give a detailed description of the SSB project (Slow Shaft Brake) characteristics for the SH130B winch and its usage, maintenance and emergency requirements by way of texts, drawings and technical data sheets.

Property of this manual is reserved and it is forbidden to reproduce it, even partially, without the written authorisation of Sicor S.p.A..

This manual is an integral part of the SSB supply and must be kept in a protected place that is also easy to access in the case of need.

For any problems or if this manual is lost or damaged please refer to:

Registered Office and Factory

Viale Caproni N°32 (Zona Industriale)

38068 Rovereto (TN) – Italy

Phone +39-0464 484 111 Fax +39-0464 484 100

www.sicor-spa.it

info@sicor-spa.it

2. PROJECT DESCRIPTION

The SSB project is a device to protect against excess speed of the cab when ascending and/or uncontrolled movements upwards or downwards with the doors open for traction drive lifts (EN 81-80, 5.9.4).

The device consists of an electromagnetic clutch brake connected directly to the pulley shaft by means of a tongue and groove system and constrained to the winch with a bolted support. Assembly of this type of brake requires a particular winch configuration so the choice has to be made when placing the order for the machine.

This device helps meet safety requirements for existing plant and is manufactured in compliance with current regulations, in particular:

Machinery Directive 2006/42/EC, 2014/33/UE, EN 81-20, EN 81-50, UNI EN 12100, [95/16/EC, EN81-1]

2.1. LIABILITY AND WARRANTY

The SSB must be installed on the SH130B winch by qualified personnel in compliance with these instructions.

Bear in mind that this manual can in no way take the place of the experience of lift installers, maintenance engineers or those who repair lifts.

The responsibility for training and refresher courses of workers lies with the company assigned to install and service the lift.

Sicor S.p.A. does not accept any responsibility for damages caused by an improper use or for damages deriving from the result of actions different from those described in this manual and that can compromise the characteristics of the product.

The product is covered by a 24-month warranty that starts from the date of dispatch.

The product warranty can be cancelled if parts or components are installed different from those described in these instructions.

For the technical details about the components to buy, this manual in no way takes the place of the actual instructions provided with the subject parts and enclosed with this document.

3. SSB PROJECT

The SSB device installed on SH130B type winches consists of the following components (Figure 1) and in particular:

- Winch with extended pulley shaft
- Electromagnetic brake device
- Brake support
- Accessories
 - SSB power supply
 - Extended shaft protection (only for the SSB option supply)
 - Hexagonal wrench bracket and SSB release screws

Figure 1 – SSB-SH130B winch assembly

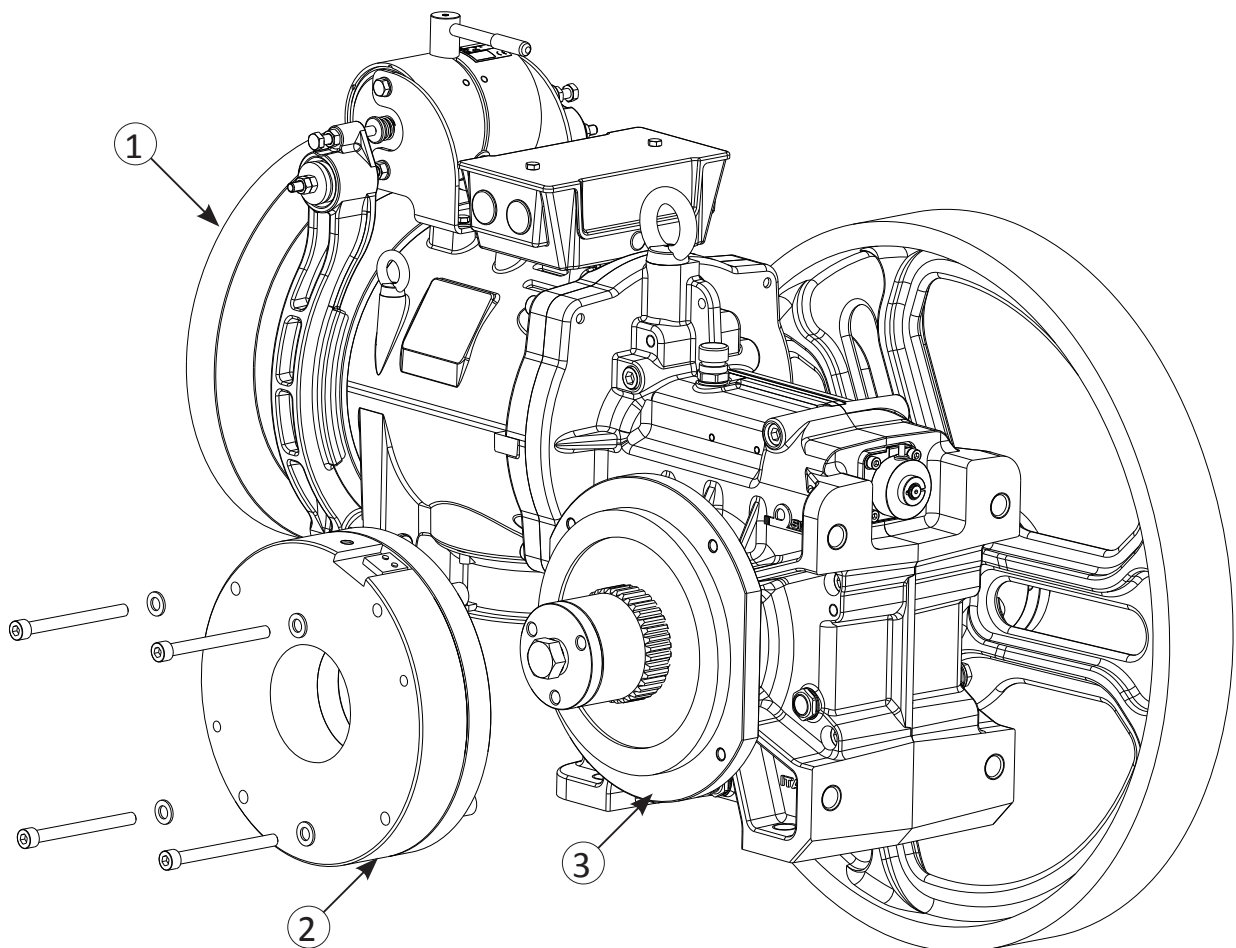

- ① SH130B Winch
- ② SSB brake group
- ③ SSB brake support flange code PIS0067

3.1. ELECTROMAGNETIC BRAKE DEVICE

The electromagnetic brake (Figure 2) is the physical braking device installed on the drive pulley shaft. It consists of an electromagnetic body, a clutch disc and a hub with knurled coupling. This device is open (slow shaft of the free winch) when powered with current or closed (braked slow shaft) when there is no power supply. It is supplied with a mechanical blocking device (transport screws with red coloured head) that must be removed before starting the device. The following table gives the technical features of the electromagnetic parking brake (Table 1).

Figure 2 – Warner VAR08-SZ1050 ERS/1000 brake - exploded view of parts and complete assembly

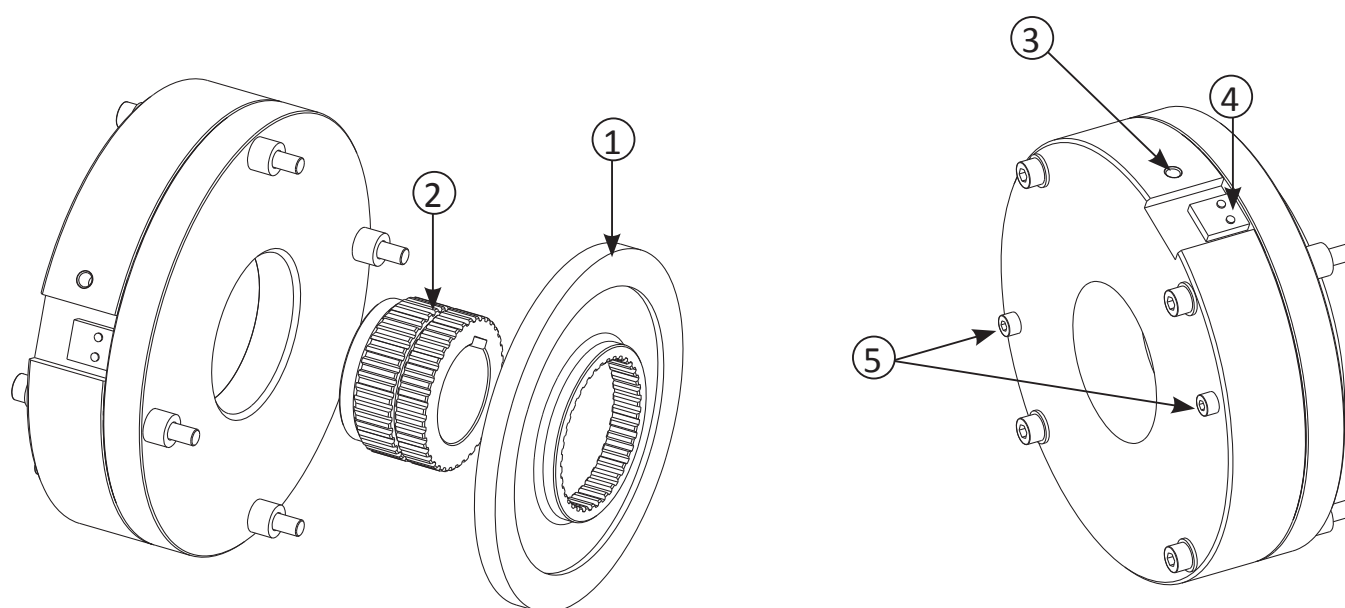

- ① Clutch disk with the flange side boss
- ② Hub
- ③ M10 thread
- ④ Microswitch
- ⑤ Transportation screws

Table 1 - Technical features of the Warner ESR VAR08-SZ1050/1000 brake.

TECHNICAL SPECIFICATIONS	
Brake type	Warner ERS VAR08-SZ1050/1000
Torque [Nm]	1000
Rated voltage [Vdc]	103.5
Over-excitation voltage [V]	207
Rated current [A]	0,70
Over-excitation current [A]	1,40
Resistance [Ohm]	148
Rated power [W]	72,4
Over-excitation power [W]	289,5
ED [%]	60 (100% ON REQUEST)
Weight [kg]	33,6
Maximum rotation speed [rpm]	250
Air gap [mm]	0,3 + 0,1/0
Max. air gap [mm]	0,7
Operating temperature [°C]	0/40 °C
Protection class (electrical) []	IP42
Level of insulation []	Class F (155°C)
Microswitch	--
Voltage [Vdc]	24
Current [mA]	10 - 100

The specifications given in the table comply with the Warner-Electric-Europe technical documentation.

3.2. BRAKE SUPPORT

The brake support is the adaptor used to install the SSB emergency brake on a SH130B winch. It comprises a mounting flange (CODE: PIS0067) with threads for anchoring the brake body. This flange is bolted directly on to the main body (shaft) of the winch (Figure 3).

Figure 3 – Electromagnetic brake support, front flange (CODE: PIS0067).

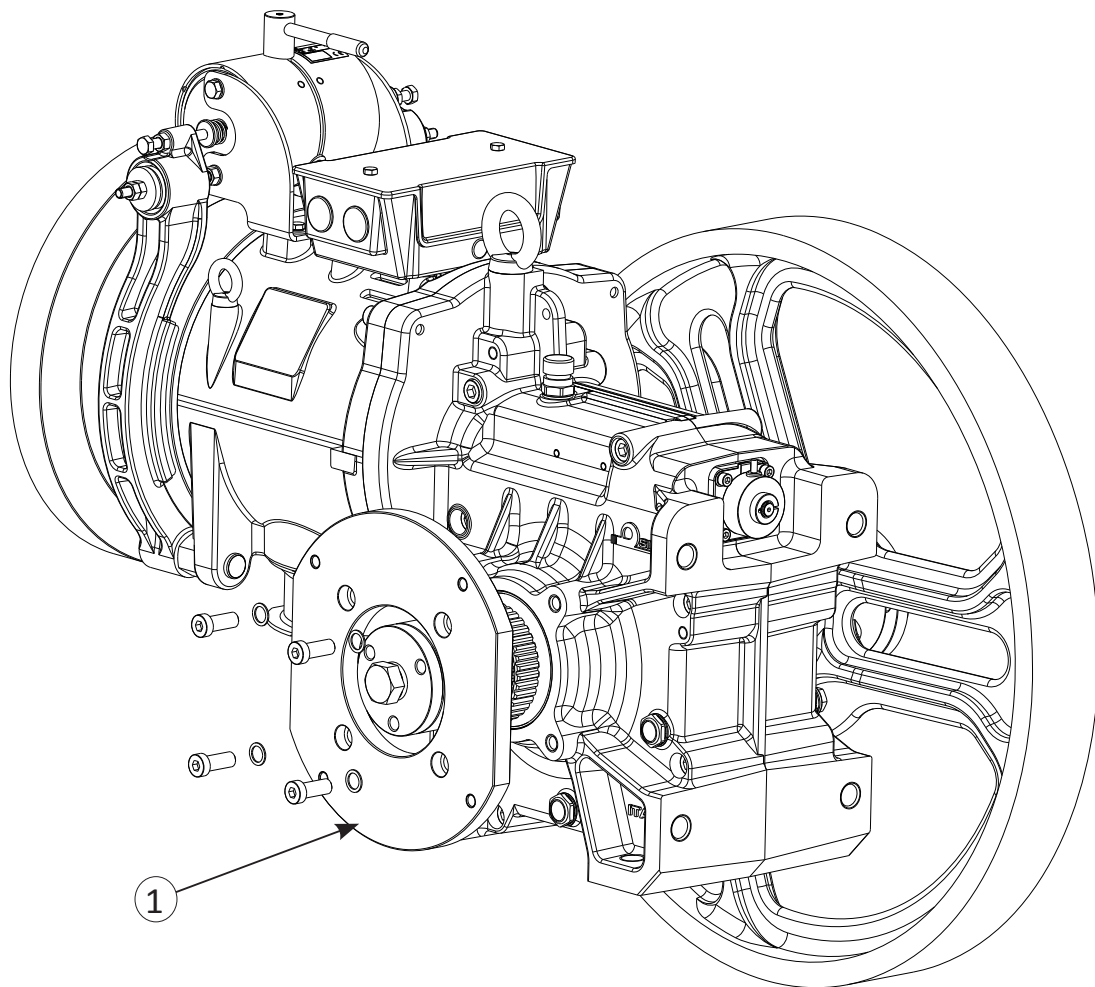

① SSB brake support flange code PIS0067

3.3. ACCESSORIES

Warner Electric Europe power supply (CODE: GEN0122) for electromagnetic brake (Figure 4). The following technical characteristics comply with the specifications given in the Warner Electric Europe manual, code: SM383 rev.:03/06 (Table 2).

Table 2 – technical features brake power Warner CODE: GEN0122

Supply voltage [VAC]	max. 230
Frequency [Hz]	50/60
Output voltage [VDC]	103.5
Current [A]	max. 4
Power output [W]	max. 414
Maximum power permitted (t=2s) [W]	828

Figure 4 - SSB Brake power supply CODE GEN0122 and overall dimensions of the component.

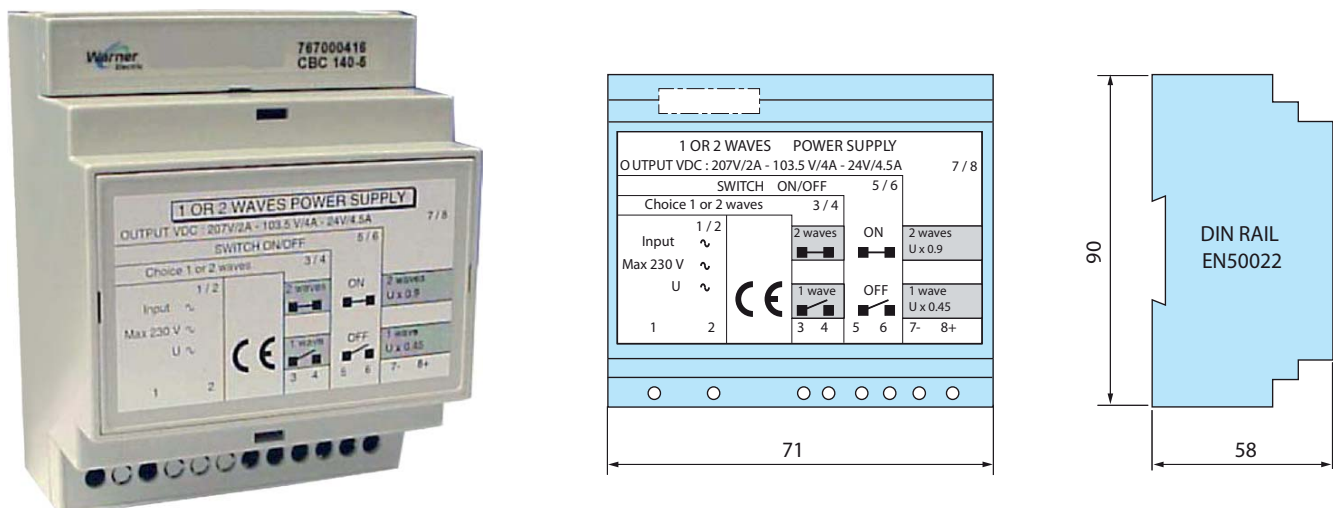

- Plastic guard for the extended pulley shaft (CODE COP0056).
- Hexagonal wrench bracket and brake release screws kit (CODE: GEN0127): metal wall mounting bracket (CODE: GEN0124) or control unit with hex wrench (CODE: GEN0123) and seats for SSB brake release screws.

Figure 5 – Wall bracket kit with hexagonal wrench and housings for the SSB release screws (CODE: GEN0127).

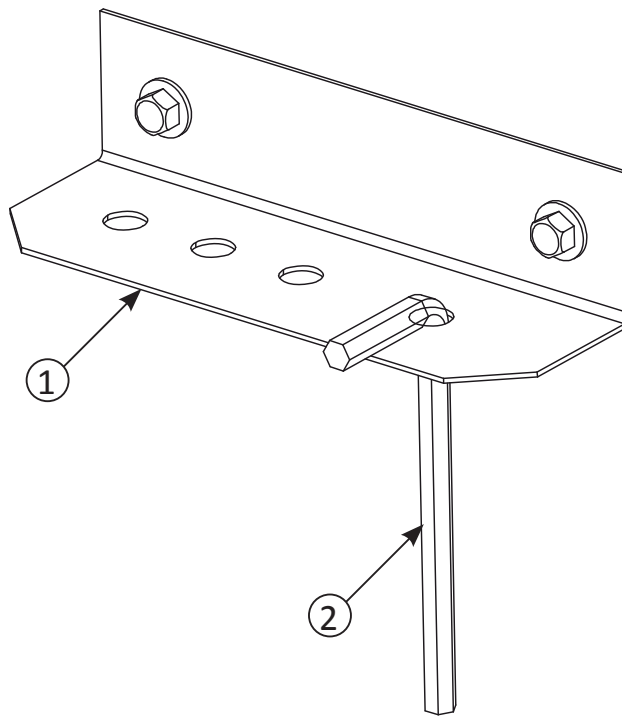

① SSB brake wall bracket code: GEN0124

② SSB brake release hex wrench code: GEN0123

4. OVERALL DIMENSIONS

Figure 6 – Overall dimensions in the case of SH130B winch with SSB option without the drive pulley

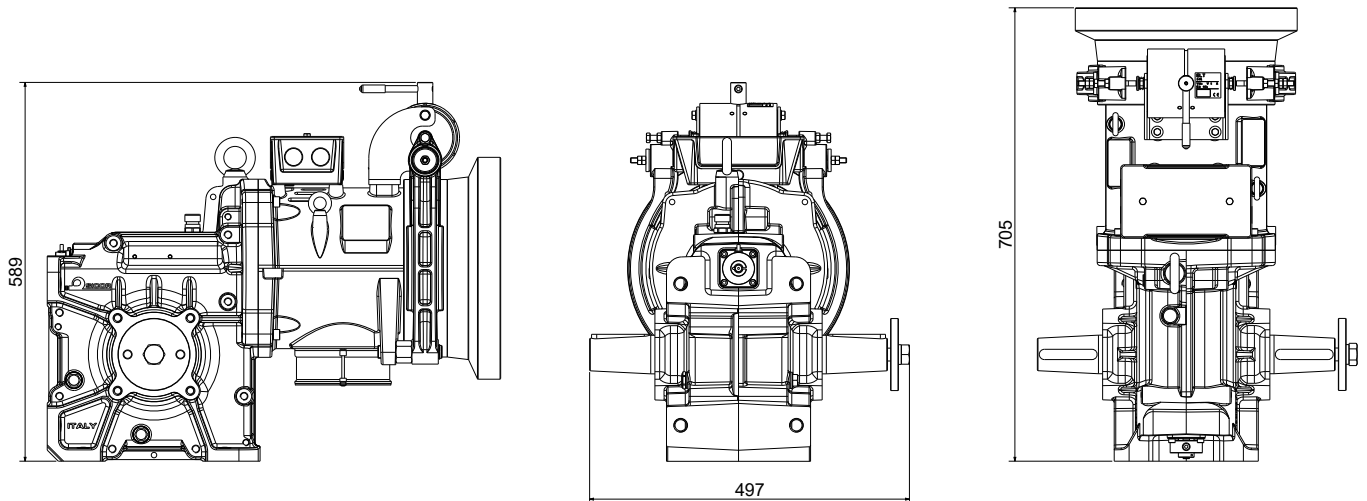
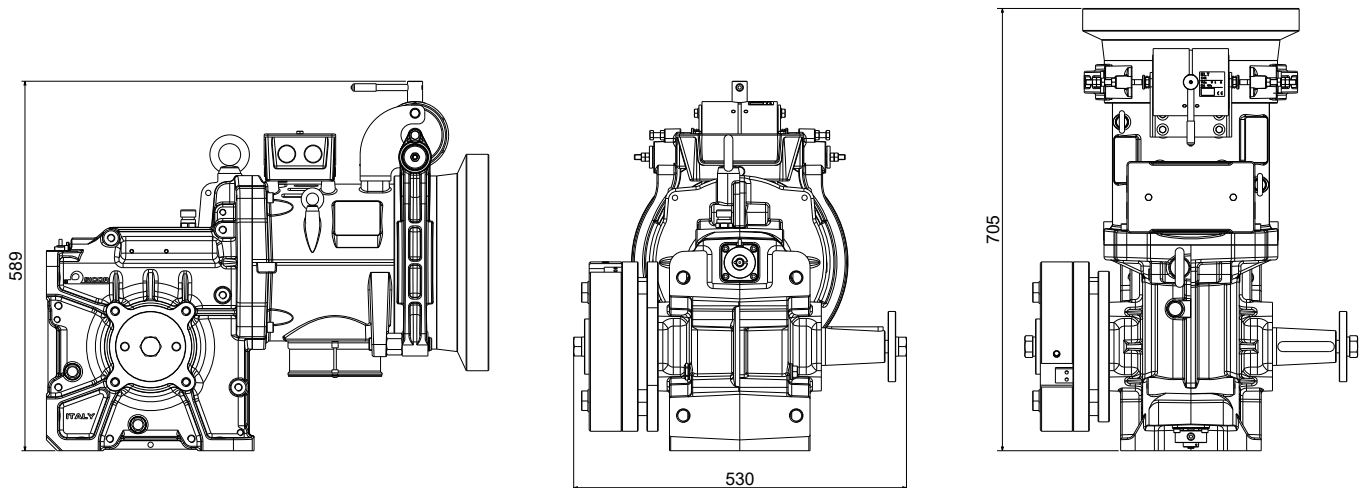

Figure 7 – Overall dimensions in the case of SH130B winch with emergency SSB (complete kit) without the drive pulley



5. SSB SUPPLY

The SH130B type of winch includes various types of supply. In particular, the product range is divided in:

- Complete SSB-SH130B kit.
- SSB-SH130B winch option.
- Complete Kit for SH130B winch (CODE: XFR0292 duty cycle 60%, XFR0293 duty cycle 100%).
- Accessories.

Details of the various types of supply, listed previously, are given in the following paragraphs.

5.1. COMPLETE SSB-SH130B KIT

The complete SSB kit on the SH130B winch comprises the supply of the following components:

- SH130B winch with extended pulley shaft.
- Brake support flange (CODE: PIS0067).
- Electromagnetic Warner VAR08-SZ1050 ERS/1000 brake (CODE: FAL0042 duty cycle 60%, FAL0043 duty cycle 100%).

Hexagonal wrench bracket kit with housing for SSB release screws (CODE: GEN0127).

5.2. SSB-SH130B WINCH OPTION

The product supply for this configuration comprises:

- SH130B winch with extended pulley shaft.
- Plastic guard for the extended pulley shaft (CODE COP0056).

5.3. COMPLETION KIT

The completion kit includes:

- Brake support flange (CODE: PIS0067).
- Electromagnetic Warner VAR08-SZ1050 ERS/1000 brake (CODE: FAL0042 duty cycle 60%, FAL0043 duty cycle 100%).
- Hexagonal wrench bracket kit with housing for SSB release screws (CODE: GEN0127).

5.4. ACCESSORIES

- Electromagnetic brake power supply (paragraph 3.3): the supply does not include electric connecting cables (CODE: GEN0122).

6. INSTALLATION AND MAINTENANCE

Installing and/or maintenance may only be done by competent personnel, authorised to access the machinery and having the necessary equipment and instruments.

Before starting any installation and/or maintenance work, attention must be given to the safety requirements given below in order to avoid accidents and damage to the product components:





- Make sure you have the appropriate personal protection equipment (helmet, body harness, gloves, safety shoes).
- Always secure equipment and other objects to avoid them accidentally falling from a height.
- Make sure that the power has been disconnected before working on electrical equipment.
- Only install the electrical system and/or the connections once you have read the relative instructions.
- Before starting installation, see if there are any structural and space limitations where the installation / maintenance work will be carried out.
- It is advisable to consider where and when you will be working and which assembly/maintenance procedures you will follow.
- Take account beforehand of all significant limitations that may regard the various operation phases and do not start work without first evaluating the consequences.

7. SAFETY PRECAUTIONS

Installation personnel are responsible for making sure that installation and maintenance are carried out in accordance with the essential health and safety protection criteria and requirements.



Installation and maintenance personnel must observe and remain updated in relation to accident prevention regulations and legal obligations to avoid injury to persons or damage to the product during installation, maintenance and repair.

Important warnings regarding safety and hazards are signalled using the following symbols.

	Warning of high hazard risk (e.g.: zones of shearing, cutting, crushing, etc.).
	Generic hazard warning.
	Risk of damage to parts of the machinery (for example due to incorrect installation or similar).
	Symbol to indicate additional important information.

8. TRANSPORTING AND HANDLING LOADS

Assembly/maintenance work may mean loads have to be transported and/or handled.

	<p>Before lifting and/or moving a load by hand, each time check how much it weighs and decide the best way to handle it while bearing in mind any standards or laws in this regard..</p>
	<p>Bear in mind the following when handling loads:</p> <ul style="list-style-type: none"> - When lifting and transporting loads, avoid to move suspended loads over people. - Always visually inspect the lifting means and harness (winches, hooks, ropes. etc.) before using or starting them. - When harnessing the load, the lifting point must be located near the centre of gravity of the load itself to avoid any rotating effects and/or tipping over.

9. INSTALLING THE COMPLETE SSB KIT

- Place the brake securing flange CODE: PIS0067 at the extended pulley shaft. Position the completely painted part towards the winch so that it remains in the exposed area for contact with the surface of the clutch.



Incorrect positioning of the brake support flange may affect correct operation functioning of the device.

Then secure the component to the winch body using 4 x M12x30 screws and 4 x M12 growers with a tightening torque of 85 Nm.

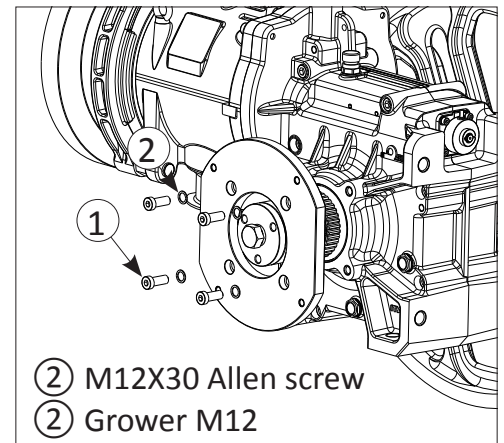

- Use dial gauge to check the perpendicularity of the brake support flange with pulley shaft extension. Perform this check at several points as shown in the figure. The maximum deviation from perpendicularity is ± 0.1 mm.



Incorrect positioning of the brake support plate causes significant variations when braking. If necessary, loosen the screws and reposition the components correctly. Use calibrated metal shims as required to ensure to the correct positioning of the component.

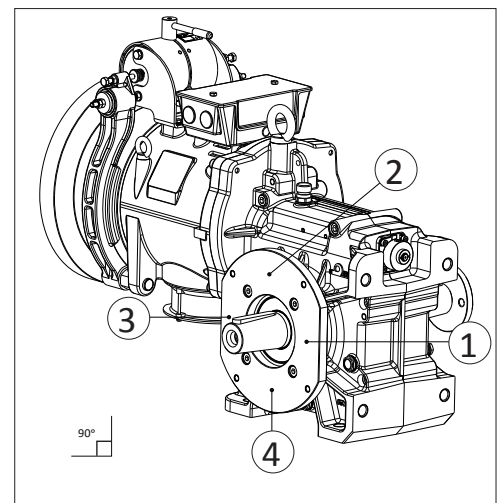

3. Position the brake hub on the shaft with the knurled part towards the brake supporting flange and lock in position with the washer and the Hex Head M20x60 screw with torque of 300 Nm.

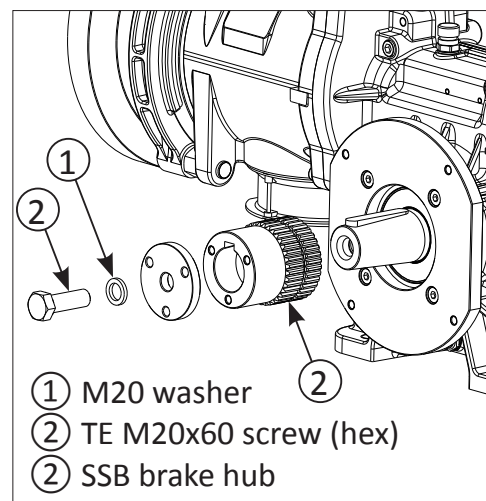

4. Fit the clutch disc on the hub with the projection facing inwards. Check that the clutch surface is in uniform contact with the brake securing flange (CODE: PIS0067). If necessary repeat the procedure outlined at point paragraph 2 for correct positioning of the flange.



The clutch surface is designed to work in dry conditions. The friction material must not come into contact with any type of oil, grease, or abrasive powder.

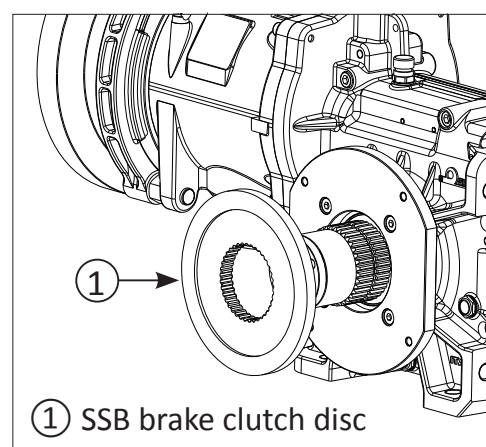

5. Align the brake with the securing flange and fasten in position using the screws supplied (4 M10x110 and 4 M10 safety washers). Tighten the fastening screws with a torque wrench in a star sequence, using a pre-tightening torque of 25Nm and a final torque of 75Nm ($\pm 10\%$).

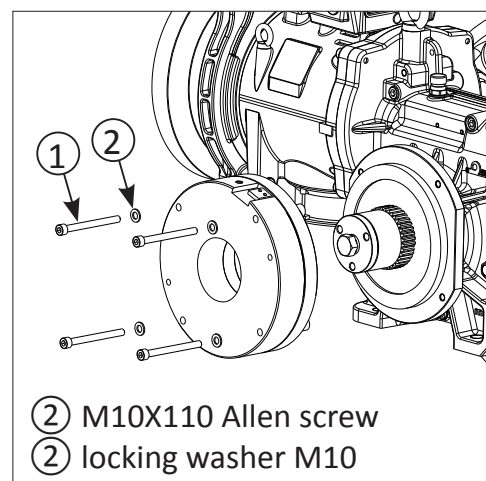



The brake is intended for static applications and/or as a safety brake. Dynamic brakings are limited to emergency and trial brakings.

6. Fit the SSB brake protective cover (COP0122 if present) with the two brake fastening screws

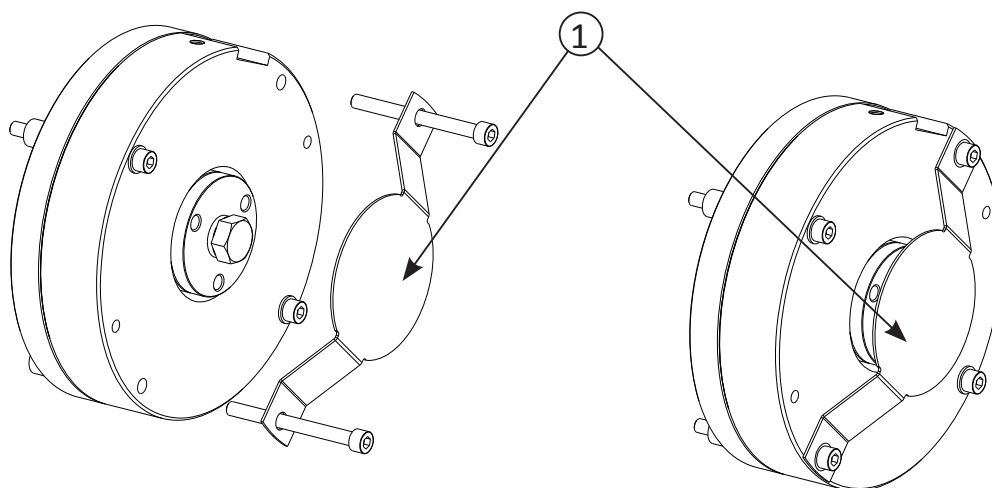

- ① SSB brake protection cover code: COP00122

7. Mount the brake release screw bracket (CODE: GEN0127) - supplied - inside the control panel or near it. Then remove the two transport screws of the brake, putting them in their housings.

Electrically connect the device following the indications given in paragraph 12.

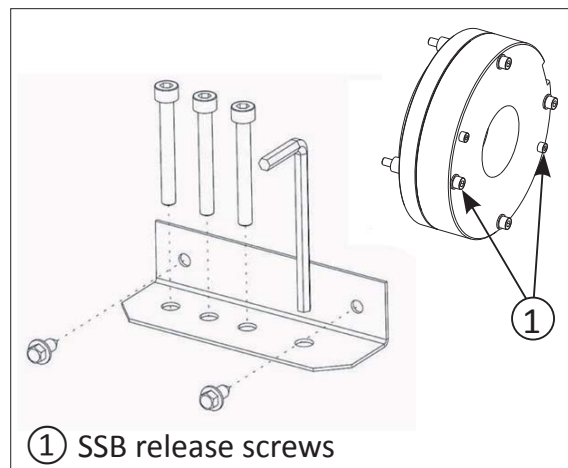

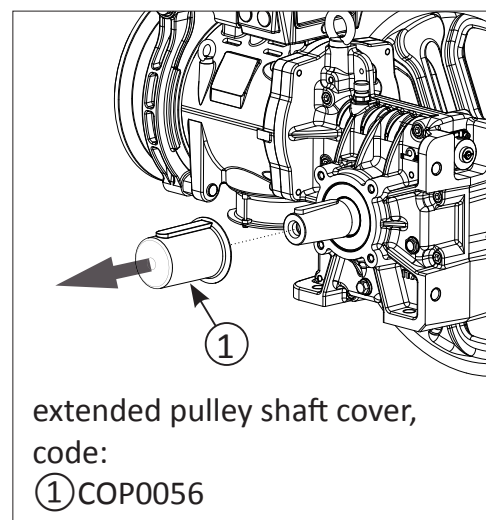

10. COMPLETION KIT INSTALLATION

- Check the correct position of the winch.
- Remove the plastic cover from the extended pulley shaft (CODE: COP0056). If necessary, clean the component thoroughly before continuing with installation.
- Follow steps 1 to 7 in paragraph 9 of this manual.



11. ELECTRICAL CONNECTIONS

	All electrical connections must be made with the main switch in the OFF position.
	Make sure that the rated supply voltage is maintained at all times.
	Direct current is used to power the brake so as to have a very reduced turn-on time of the brake which is ideal in the case of emergency stops.

These instructions in no way replace the Warner Electric Europe technical documentation enclosed with this manual.

11.1. BRAKE

The VAR08-SZ1050 ERS/1000 brake works with direct current supply and an over-excitation profile (VDC207/103.5). The brake power supply (CODE: GEN0122) is not included in the standard SSB supply (complete kit) but is an optional accessory available only on request.

Electrically wire the device, connecting the cable leading from the brake to the power on the control panel or to the power supply provided. Reversing polarity will not affect how the brake works.

The connection cables must have an adequate cross section to prevent any sudden rise in voltage between source and brake. The tolerance in the supply of voltage to the brake terminals is +5%/-10%. The brake must only be powered after the transport screws have been removed - they can be easily identified by their red coloured heads.

11.2. MICROSWITCH

If there is a power failure to the brake coil (slow shaft braked) the microswitch contacts change over to the NC position as indicated in Figure 8; on the contrary, in the case of a powered brake coil (slow shaft free), the microswitch is changed over to the NO position. Please see the data in Table 1 for the electrical specifications.

Figure 8 – Microswitch electrical connections: contact change-over in the case of no current to the SSB coil

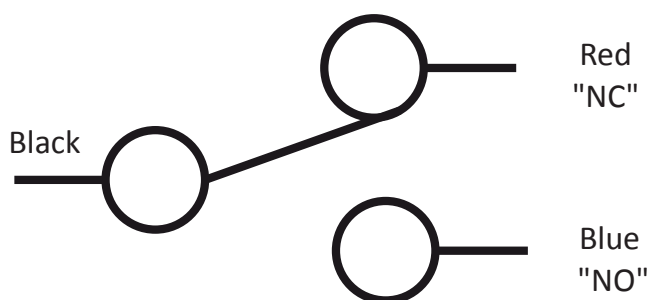

11.3. SSB power supply

The brake power supply (CODE: GEN0122) is not included in the standard SSB supply (complete kit) but is an optional accessory available only on request.

Do the wiring, connecting the main power (maximum voltage 230VAC) to terminals 1 and 2 on the terminal block. Now connect the brake coil cables to terminals 7 and 8 and the SSB drive signal to terminals 5 and 6 (Figure 9). Lastly connect a timed relay (0.5-2s / 9A-400V) to terminals 3 and 4 for controlling over-excitation. The switch for the SSB drive (9A - 400V) and the relay are not included in the supply.

Figure 9 – Wiring diagram for the SSB power supply: KA switch (9A, 400V) and the relay are not included in the supply

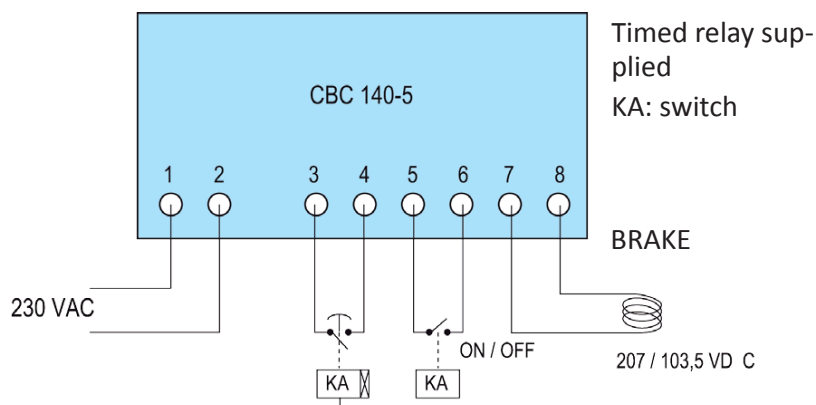

12. STARTING THE WINCH

This paragraph is only valid in the case of the complete kit or completion kit. Before starting the device, make sure all the installation instructions given in this manual have been complied with and then proceed as explained below:

- Check that the brake clutch surface is evenly touching the fixing flange.
- Check that the fastening screws of the SSB are tightened correctly.
- Check that the fastening screws of the flange are tightened correctly.
- Check that the electrical connections are made correctly.
- Make sure the brake transport screws have been removed and are in the housings in the bracket supplied.
- When the system is stopped check that the SSB (Figure 10) air gap is adjusted in compliance with the indications given in paragraph 13.1 of this manual. This check must be done measuring the gap with calibrated metal feeler gauges in several points around the brake's circumference.
- Move the lift a few times and check that when the winch is moving the clutch disc is not rubbing against the braking plates.
- Check the microswitch is working properly as the brake opens and closes. Adjust the microswitch if necessary, following the indications in paragraph 13.2 of this manual.

Figure 10 – Check the brake air gap with calibrated metal feeler gauges in several points around the SSB device

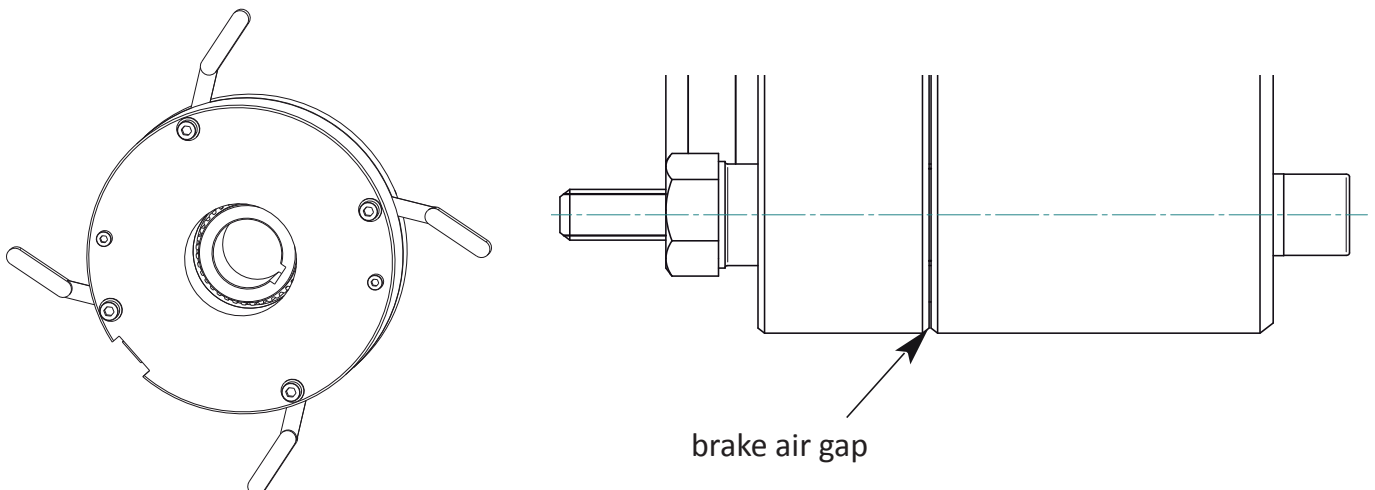

13. CHECKS AND MAINTENANCE WORK

The purpose for the checks and maintenance work is to ensure the efficiency and maintain the SSB device in proper working order. Maintenance frequency can vary as it depends on the frequency of use, age, working conditions, location, type of building and on the environmental conditions where it is installed.

To this end, the company providing the assistance and maintenance service must prepare a suitable maintenance schedule for the subject case with maintenance times as short as reasonably possible without in any way compromising the safety of people.

The standard checks and verifications for the single components of the SSB parking brake are given below.



All checks and maintenance work must be carried out paying particular attention to the safety of the maintenance engineer and of other people.

- If the guard is mounted on the SSB, remove it.
- Check the correct tightness of all the device's fastening screws.
- Check the state of wear of the brake lining, replacing it if necessary.
- Check that the front surface of the fixing flange is perpendicular to the pulley shaft axis.
- Check that the clutch surface is evenly touching the fixing flange. Adjust the position of the brake support flange if necessary.



An uneven contact of the clutch surface will compromise the braking action of the device and make it wear more quickly.

- Check the air gap, measuring with calibrated feeler gauges in several points of the device, adjusting the gap if necessary as explained in paragraph 13.1.
- Check that the microswitch is working properly, adjusting it if necessary as explained in paragraph 13.2.
- Check that the electrical connections are made correctly.
- Clean the device thoroughly.
- If the SSB has a cover, put it back in place.

13.1. SSB BRAKE AIR-GAP ADJUSTMENT

The SSB brake is typically provided with air-gap already regulated. The correct value must be 0.3 mm +0.1/0. Check it, using calibrated metal feeler gauges as indicated in figure 10. If this value is greater than the maximum indicated, the clutch disc must be replaced.



Before starting to check the SSB, make sure the winch is NOT working and that the main brake is working properly.



These instructions in no way replace the Warner Electric Europe technical documentation enclosed with this manual.

13.2. SSB BRAKE MICROSWITCH ADJUSTMENT

The SSB device is typically supplied with the microswitch already adjusted.

In the case of necessity, adjust it as explained below:

Figure 11 – Microswitch and adjustment screw

- ① Microswitch
- ② Microswitch adjustment screw
- ③ Air-gap

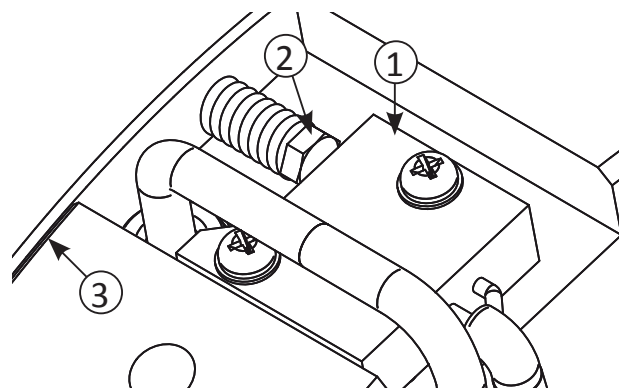

An uneven contact of the clutch surface will compromise the braking action of the device and make it wear more quickly.

- Put a calibrated 0.15 mm feeler gauge by the microswitch adjustment screw and the movable brake plate.
- Power the brake and turn the adjustment screw until the point of contact is reached with the microswitch (Figure 11).
- Remove the thickness gauge.
- Check correct operation by engaging/disengaging a few times.
- Repeat the operation if necessary.



These instructions in no way replace the Warner Electric Europe technical documentation enclosed with this manual.

14. MANUAL EMERGENCY OPERATING

These instructions describe the emergency manual manoeuvre in the case of an SH130B winch equipped with an SSB parking brake (Slow Shaft Brake), type Warner ERS VAR08-SZ1050/1000.

14.1. WARNINGS

	<p>MANUAL EMERGENCY MANOEUVRE IS A DANGEROUS TASK. IT CAN BE USED TO MOVE THE CAB EXCLUDING ALL THE PLANT SAFETY CONTACTS. FOR THIS REASON, ANYONE WHO PERFORMS THIS OPERATION MUST HAVE BEEN CAREFULLY TRAINED BY SPECIALISED PERSONNEL AND MUST BE AWARE OF THE RISKS INVOLVED.</p>
---	---

Assistance in the event of an emergency must only be provided by expert, specially trained personnel. All the operations performed in the event of an emergency must strictly follow the instructions in this manual. A copy of this document must therefore be kept near the device and be easy to access if necessary.

In the event of an emergency entailing manual manoeuvres strictly observe the following instructions:

- Follow local safety requirements.
- Do not neglect the safety of passengers at risk in any way.
- Do not put them at risk in any way.
- Make sure that their actions do not create hazardous situations for third parties.
- Communication with any passengers in the cab must be established as soon as possible in order to reassure the people present. This can help to establish the position of the cab in the well more precisely.
- Before each intervention, first inform the passengers of what you intend to do.
- After completion of work, make sure there are no problems with normal operating of the plant.

14.2. INSTRUCTIONS FOR AN EMERGENCY MANUAL MANOEUVRE

	<p>AN EMERGENCY MANUAL MANOEUVRE IS DANGEROUS.</p>
---	--

It can be used to move the cab excluding all the plant safety contacts.

For this reason, anyone who performs this operation must have been carefully trained by specialised personnel and must be aware of the risks involved.

	<p>For correct emergency manual operating, carefully follow these instructions.</p>
---	---

- Check that all lift doors of the floors are closed and they cannot be opened in any way.
- **MAKE SURE THE CAB IS AT A FLOOR LEVEL.**
- Place the main switch on the control panel to the **OFF** position.
- Reassure the passengers in the cab, explaining to them exactly what you intend to do.

Figure 12 – Top view of the main winch brake lever: locking/releasing positions of the main brake lever.

Positions of the top main brake lever

- ① brake active (closed)
- ② brake inactive (open)

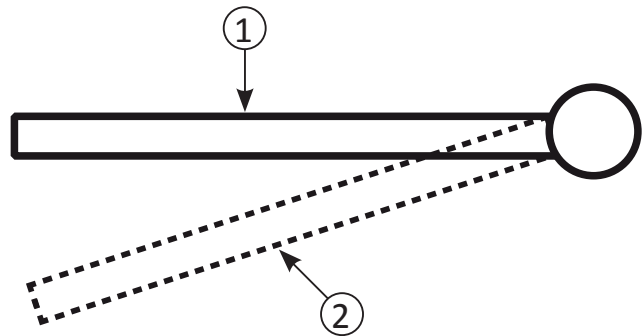

The passengers must not try to force the cab doors open or attempt to get out of it in any way.

- Check that the operating conditions of the main brake and winch are safe for moving the cab.



To see if the main brake on the winch is working properly, check:

- if the brake shoes are broken
- if the brake linings are damaged which limits the contact surface
- if contact with the braking surface is uniform

- Release the main brake positioned at the top of the winch using the manual release lever (Figure 12 – ②).
- With the main brake released, try turning the winch's flywheel in both directions, making certain it is blocked.



If the fast shaft of the winch is turning freely or you notice excessive play, it means the winch is "out of order" and the cab is being supported only by the SSB emergency brake.



If the winch and/or the main brake are out of use or the safety is inserted, perform the rescue procedure and ensure that the cab is secure by using a special device suitable for the type of plant, place and operating conditions.

- Release manual lever to unlock the main winch brake (Figure 12 – ①).
- Retrieve the ssb brake release screws and the hexagonal wrench from the housings in the wall bracket.

- IF THE GUARD IS MOUNTED ON THE FRONT OF THE SSB, REMOVE IT.
- Release the ssb emergency brake, tightening the release screws in their place on the brake body (figure 13).

Figure 13 – SSB emergency brake release screws (opening)

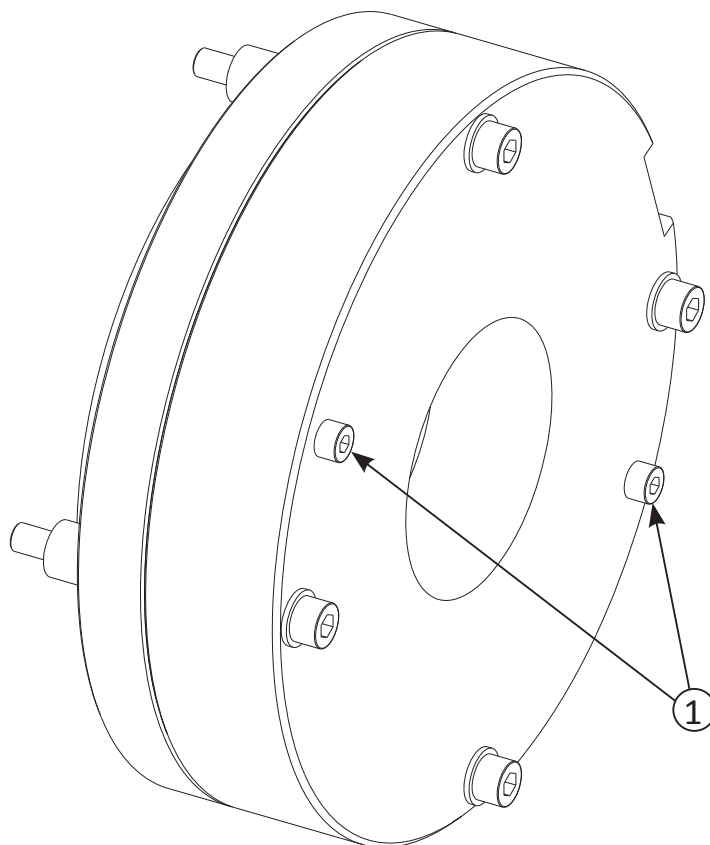

① SSB release screws

- Check rotation direction of the winch for the cab movement manoeuvre.
- Manually block rotation of the winch's flywheel.
- Release the main brake by turning the manual lever (Figure 12 – ②).
- Start the manual manoeuvre, bringing the cab to the destination floor.
- Release manual lever to unlock the main winch brake (Figure 12 – ①).
- Open the cabin doors and help the passengers.
- Close the cab doors.
- Restore the ssb emergency brake removing the release screws.
- Put the ssb release screws and the hexagonal wrench back into the housings in the wall bracket supplied.
- Put the front protection of the ssb back in place.

15. ANNEXES

15.1. TÜV CERTIFICATION FOR SH130B WINCH

ZERTIFIKAT ◆ CERTIFICATE ◆ 認証証書 ◆ CERTIFICADO ◆ CERTIFICAT



Industrie Service

Type-examination certificate

Certificate no.:	ESV 818
Certification office:	TÜV SÜD Industrie Service GmbH Westendstr. 199 80686 München - Germany
Applicant/ certificate holder:	WARNER Electric Europe 7, rue de Champfleür BP 20095 49124 St. Barthélemy D'Anjou - France
Date of application:	2011-06-22
Manufacturer of the test sample:	WARNER Electric Europe 7, rue de Champfleür BP 20095 49124 St. Barthélemy D'Anjou - France
Product:	Braking element acting on the shaft of the traction sheave, as a part of the protection device against unintended car movement
Type:	ERS VAR08 SZ1050/----
Test laboratory:	TÜV SÜD Industrie Service GmbH Prüflaboratorium für Produkte der Fördertechnik Prüfbereich Aufzüge und Sicherheitsbauteile Westendstr. 199 80686 München - Germany
Date and number of the test report:	2011-09-09 ESV 818
Examination basis:	EN 81-1:1998 + A3:2009 (D), issue December 2009
Result:	The safety component conforms to the requirements of examination basis for the respective scope of application stated on page 1 - 2 of the annex to this type-examination certificate.
Date of issue:	2011-09-19

Certification office for products of conveyor systems
 Lifts and safety components

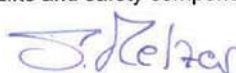
 p. p. Siegfried Melzer





SICOR S.p.A.

Head Office and Production Centre

Viale Caproni 32 (Industrial Area) 38068 Rovereto (TN) Italy

Ph.. +39 0464 484111 Fax +39 0464 484100

www.sicor-spa.it info@sicor-spa.it