

OPERATION AND MAINTENANCE MANUAL

SH130G

COD.: MUM0196 REV. 01

english

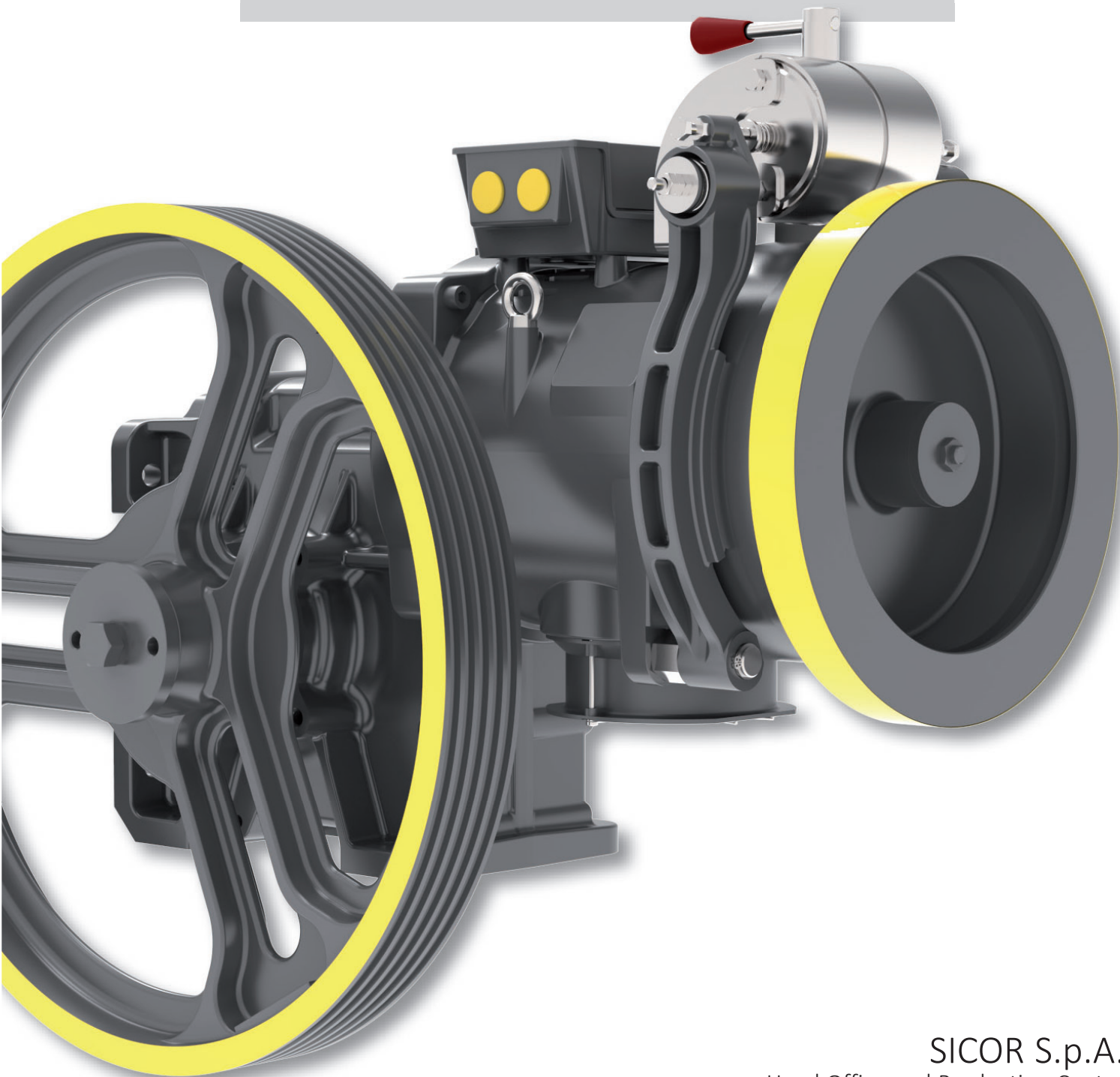

SICOR S.p.A.

Head Office and Production Centre
Viale Caproni 32 (Industrial Area) 38068 Rovereto (TN) Italy
Ph.. +39 0464 484111 Fax +39 0464 484100
www.sicor-spa.it info@sicor-spa.it

INDEX

1.	LETTER TO THE CUSTOMER	2
2.	MACHINE IDENTIFICATION	3
3.	WARRANTY	4
4.	GENERAL DELIVERY NOTES.....	5
5.	SAFETY PRECAUTIONS	6
6.	SAFETY REQUIREMENTS	7
7.	TECHNICAL FEATURES:	10
8.	MOVING THE WINCH	11
9.	NOTES FOR INSTALLATION.....	14
9.1.	MOTOR ROTATION INSTRUCTIONS.....	15
9.2.	ENCODER INSTALLATION INSTRUCTIONS	16
9.3.	VENT PLUG POSITIONING (CODE:TAP0025)	17
10.	WINCH LUBRICATION	18
10.1.	CHANGING THE OIL	18
10.2.	CHECKING THE OIL LEVEL	19
11.	ELECTRICAL CONNECTIONS	20
12.	WIRING DIAGRAM.....	21
13.	STARTING THE WINCH	22
14.	DISPOSAL/RECYCLING	23
15.	MAINTENANCE	24
15.1.	PRE-ADJUSTMENT OF THE BRAKE	25
15.2.	BRAKE ADJUSTMENT	25
15.2.1.	STROKE ADJUSTMENT	25
15.2.2.	CHECKING THE ADJUSTMENT	25
15.2.3.	ADJUSTMENT OF BRAKING TORQUE.....	26
15.3.	CHECKING THE STROKE	27
15.4.	COMPULSORY MAINTENANCE OPERATIONS.....	28
16.	MANUAL EMERGENCY OPERATING	29
16.1.	WARNINGS	29
16.2.	INSTRUCTIONS FOR AN EMERGENCY MANUAL MANOEUVRE.....	29

1. LETTER TO THE CUSTOMER

Dear Customer,

SICOR winches are designed and manufactured in accordance with the Machinery Directive 2006/42/EC, 2014/33/EU, EN 81-20, EN 81-50, UNI EN 12100, [95/16/EC, EN 81-1], in full respect of the regulations in force.

As such, they do not represent a hazard for installation and maintenance personnel when used according to the instructions supplied in this manual, and provided the relevant safety devices are always kept in good working order.

This document is designed to certify that the safety devices on the machine were in full working order when the latter was delivered, that this manual has been delivered with the machine and that the installer takes responsibility for complying fully with its contents.

SICOR declines any and all responsibility for damage caused by equipment that has been modified, tampered with or otherwise undergone any operations not in compliance with the contents of the manual, with the instructions contained therein or with the indications provided in other documents. SICOR congratulates you on choosing this product and hopes that you will be impressed by its excellent performance.

SICOR S.p.A.

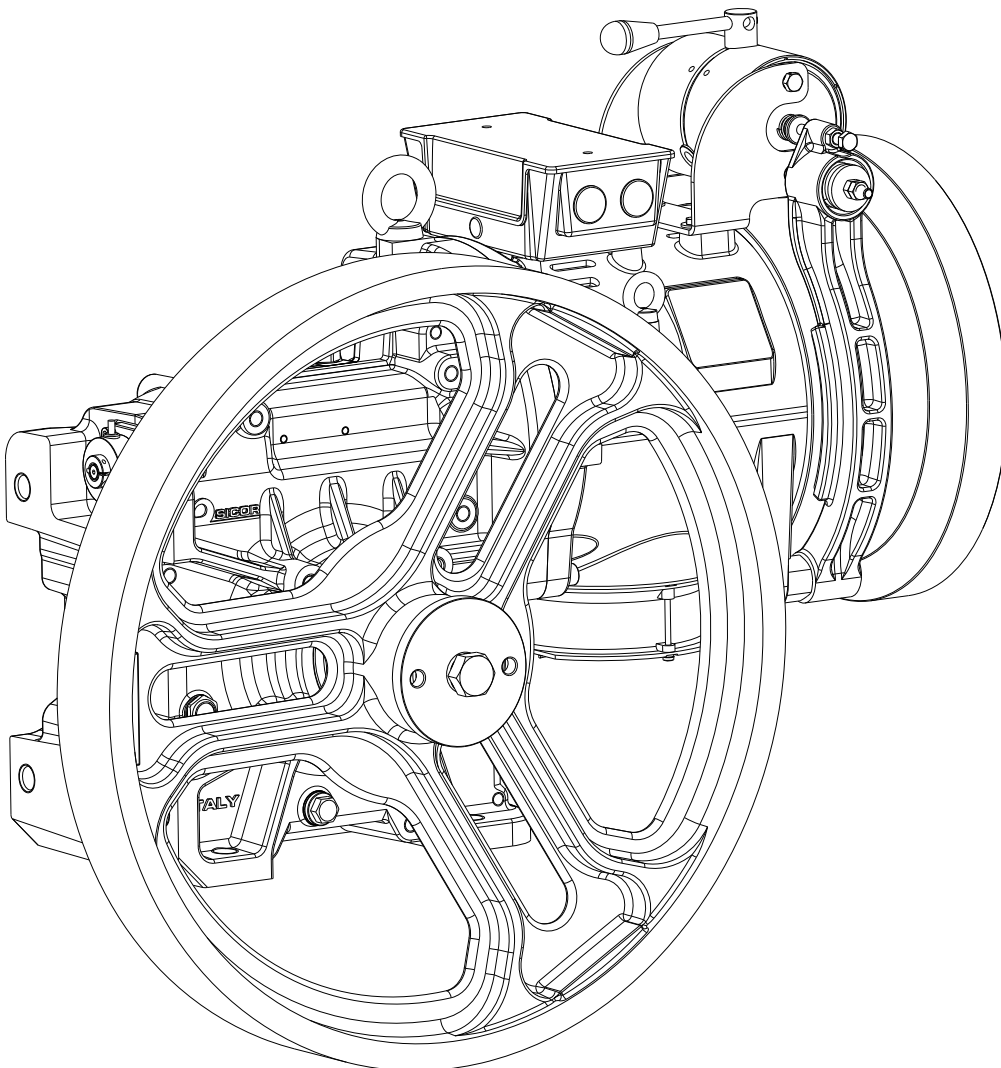

2. MACHINE IDENTIFICATION

When writing to SICOR or Sidor Service Centres with regard to winches, always quote the serial number.

This number, as well as other data regarding the identification of the winch, can be found on the plates located on the machine, electromagnet and motor as shown in the figure below.

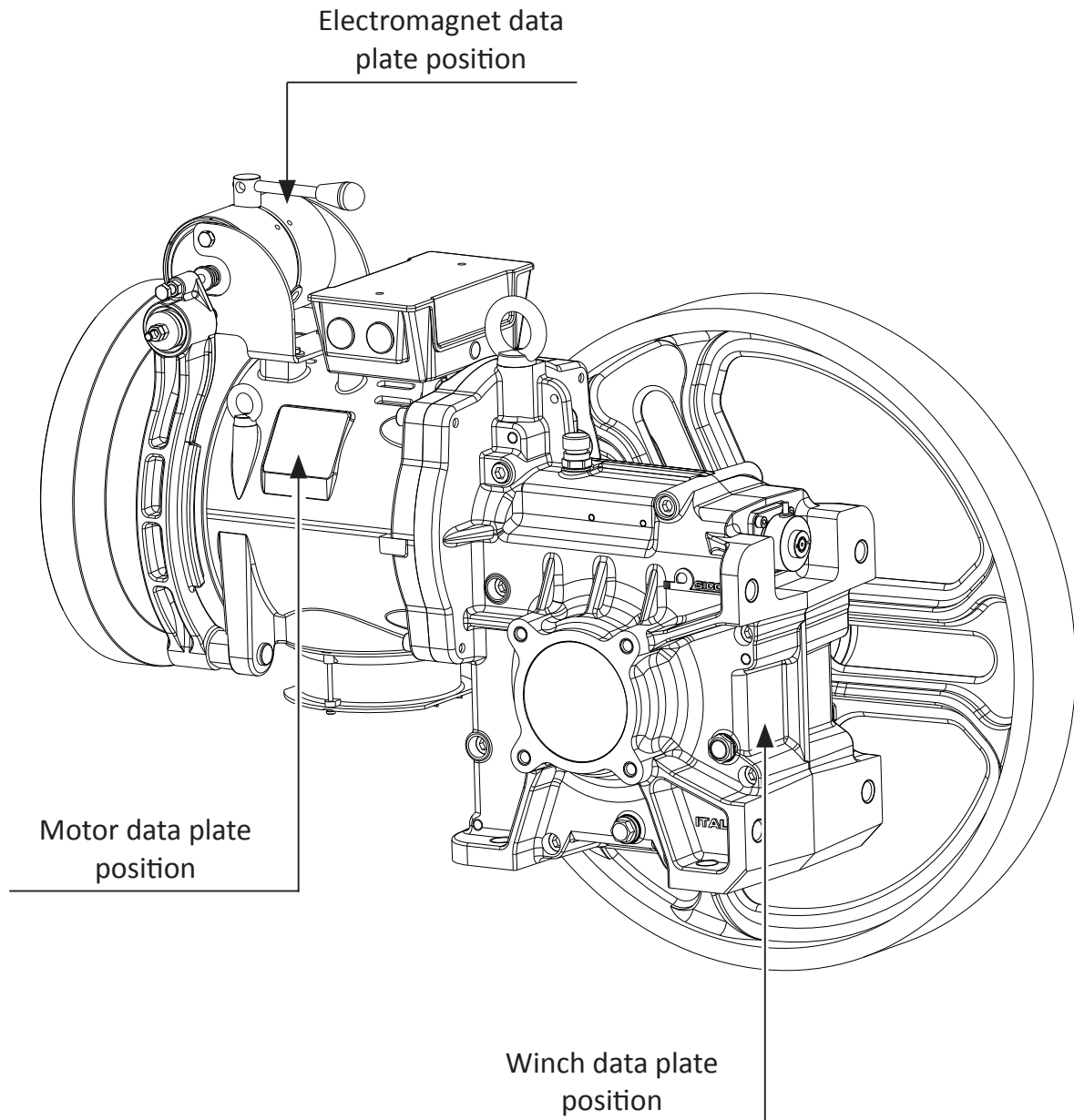

3. WARRANTY

- The warranty, apart from other contractual agreements, is regulated by the following clauses:
 - The warranty on SICOR products is valid for a period of TWO years from the date of the shipping document. During this period, SICOR will replace free of charge any component recognised as faulty.
 - A component can be declared faulty only if the fault is recognised by SICOR SpA.
 - Parts under warranty, to be repaired or replaced, must be sent to SICOR carriage paid.
 - The Customer must send any request for technical assistance to SICOR in writing. Labour, travel and board and lodging costs must be met by the Customer.

- The warranty lapses automatically when one of the following conditions applies:
 - The parts for which service has been requested have been tampered with.
 - The type of application was unauthorised or not agreed beforehand in writing with SICOR.
 - The use of the machine does not conform to the characteristics for which it was built or to the indications in the technical catalogue or in this “Use and Maintenance Manual”.
 - The identification plates are missing and the machine cannot be identified.

- The warranty does not cover operational parts subject to normal wear and tear: brake linings, bearings, electric windings.

- The warranty does not include indemnity for transport costs or machine stoppage.

- Procedures for action under warranty:
 - All warranty claims must be communicated to SICOR within 8 days of the anomaly appearing, in writing or by fax.
 - SICOR will confirm in writing or by fax any acceptance of repair work to be performed by the Customer under warranty or will send its own technicians.
 - Any faulty material replaced by the Customer must remain at SICOR's disposition for 30 days so that any necessary checks can be made or the parts shipped to SICOR if specifically requested in writing by the company.
 - Absolutely no claims will be accepted for warranty repairs that were not previously authorised in writing by SICOR.
 - In all cases, full photographic documentation of repair work must be presented; this is not only for documentary reasons but also to allow SICOR to correct or further improve the quality and reliability of its machines.

4. GENERAL DELIVERY NOTES

Winches can be shipped on pallets or in crates.
In all cases, on receipt of the winch, check that:

- the packing is undamaged
- the supply corresponds to the specifications of the order (see waybill or packing list)
- there is no visible damage to the winch or its accessories

In the event of damage or missing pieces, immediately send a detailed report to SICOR, its agent, or the shipping agent.

Spare parts or parts of equipment of the supply, when necessary, are packed in separate containers.

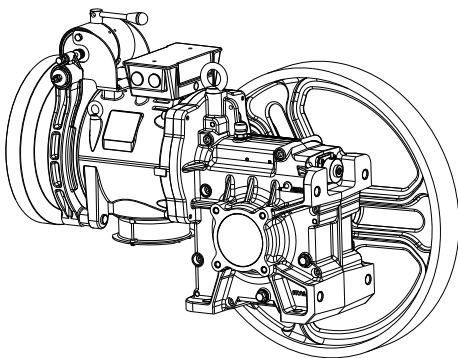

Gear motor complete with accessories according to order specifications

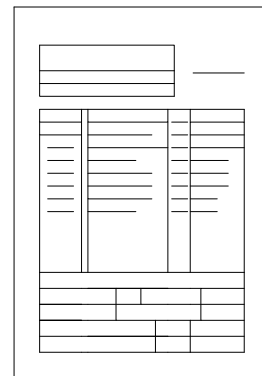

Machine data sheet Work Order

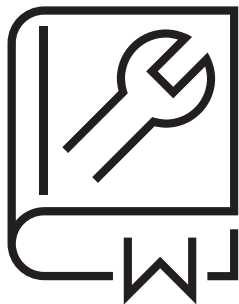

Operation manual

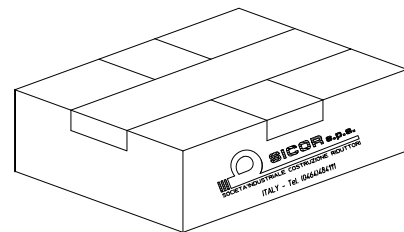





Box with spare parts (if requested))

5. SAFETY PRECAUTIONS

Installation personnel are responsible for making sure that installation and maintenance are carried out in accordance with the essential criteria and requisites for health and safety protection. Installation and maintenance personnel must observe and remain updated in relation to accident prevention regulations and legal obligations to avoid injury to persons or damage to the product during installation, maintenance and repair.

Important warnings regarding safety and hazards are signalled using the following symbols.

	Warning of high hazard risk (e.g.: zones of shearing, cutting, crushing, etc.).
	Generic hazard warning.
	Risk of damage to parts of the machinery (for example due to incorrect installation or similar).
	Symbol to indicate additional important information.

WHEN THESE WARNINGS APPEAR,
PROCEED WITH THE UTMOST CAUTION.

Definitions: INSTALLATION and/or MAINTENANCE PERSONNEL:

qualified operator recognised as such by the Customer, authorised by the Customer to work on the machine for installation and maintenance operations.

6. SAFETY REQUIREMENTS



WARNING

The winch **MUST** be installed in an area that is strictly kept under lock and key. Access to this area must be limited to qualified maintenance personnel who have been authorised by the customer. The following notice must be affixed to the door providing access to this area:

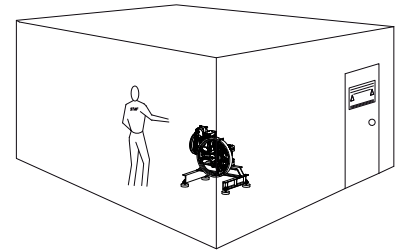

Installers or maintenance personnel must be aware of the dangers associated with the machine and must have read and understood the safety precautions in this manual.

Before installing the winch, the customer must verify that the concrete slab and/or the support structures of the shifting loads and the winch meet the required safety factors.

The Customer **MUST** also respect the distances from walls and from other machines in accordance with the directives and standards in force in the country where the winch will be installed.

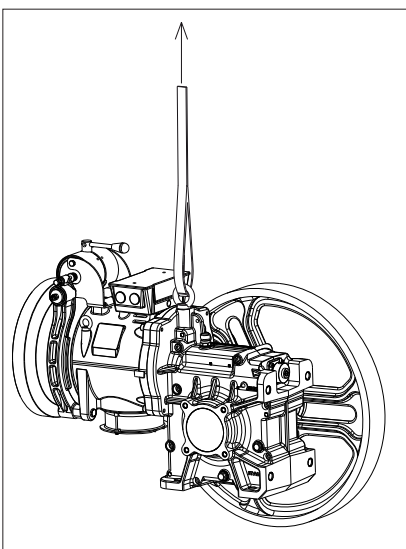
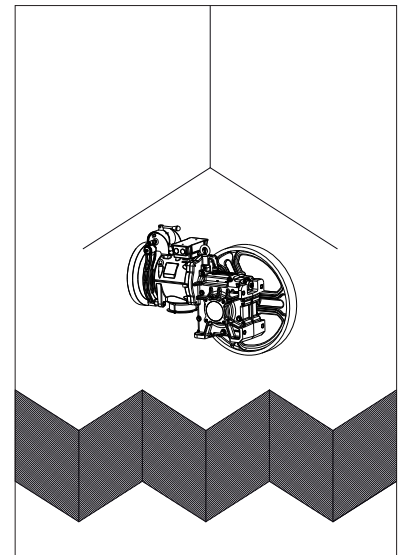

LIFTING

To move the winch (see Chap. 8 - Moving the winch) use a suspension-type lifting system connected to the eyebolts on the reduction unit and a non-metallic strap wrapped around the motor, or use an adequately sized forklift (see Chap 7 - Technical features) to lift the winch a maximum of 30 cm off the floor and move the winch slowly.



EXCLUSION OF POWER SOURCES

Before carrying out any cleaning, lubrication and/or maintenance work, maintenance personnel must put the winch out of service by disconnecting the power supply and must wait for the heated parts of the motor and the winch to reach ambient temperature.

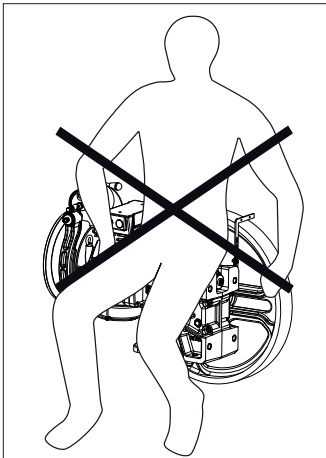
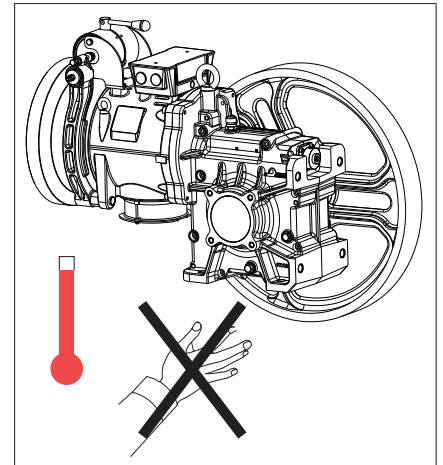

WARNING

Do not lean and/or sit on the winch, either when it is in or out of service.



WARNING

Do not approach or lean against the rotating parts (flywheel or pulley painted yellow).

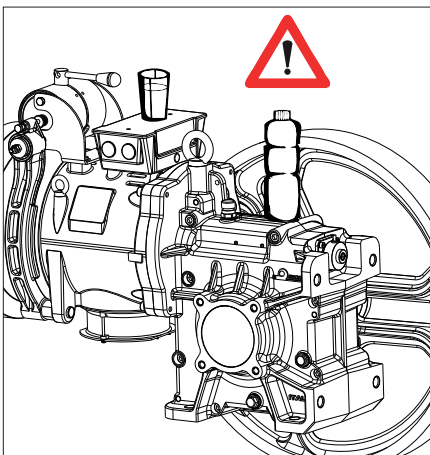
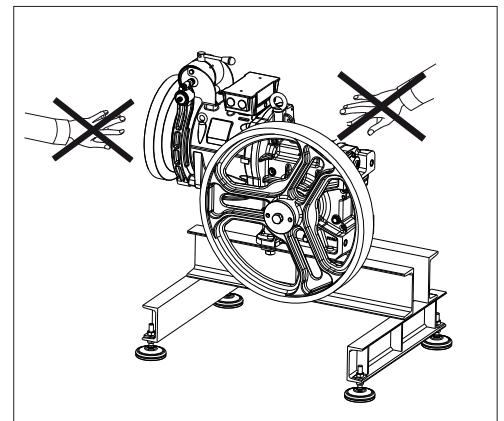

Do not deposit or place any objects or containers of liquids etc. on the winch and especially on electrical parts.



Never tamper with or disable the safety devices or by-pass them or use them for purposes other than those for which they were intended.

Do not tamper with or damage or remove the number plates. If deteriorated or illegible, immediately ask SICOR for replacement.

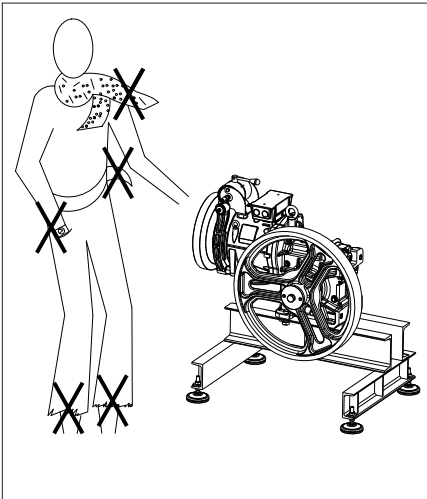
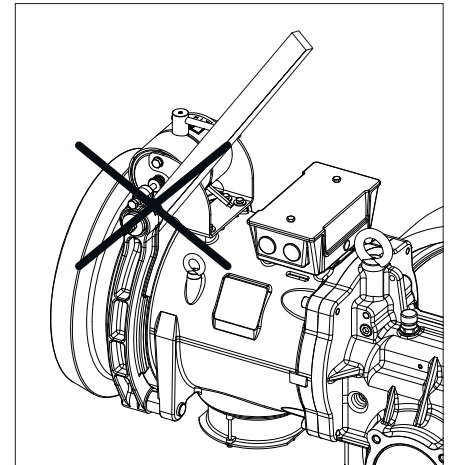

When working near the winch, installers and maintenance personnel **MUST NEVER WEAR LOOSE AND/OR TORN CLOTHING** (scarves, cravats, hats, necklaces, belts, watches, bracelets, rings, etc...).

7. TECHNICAL FEATURES:

Here are the overall dimensions of the winch in its maximum configuration.

More detailed data such as: reduction ratio, absorbed power, number of poles in motor, etc. can be found in the SICOR technical catalogue.

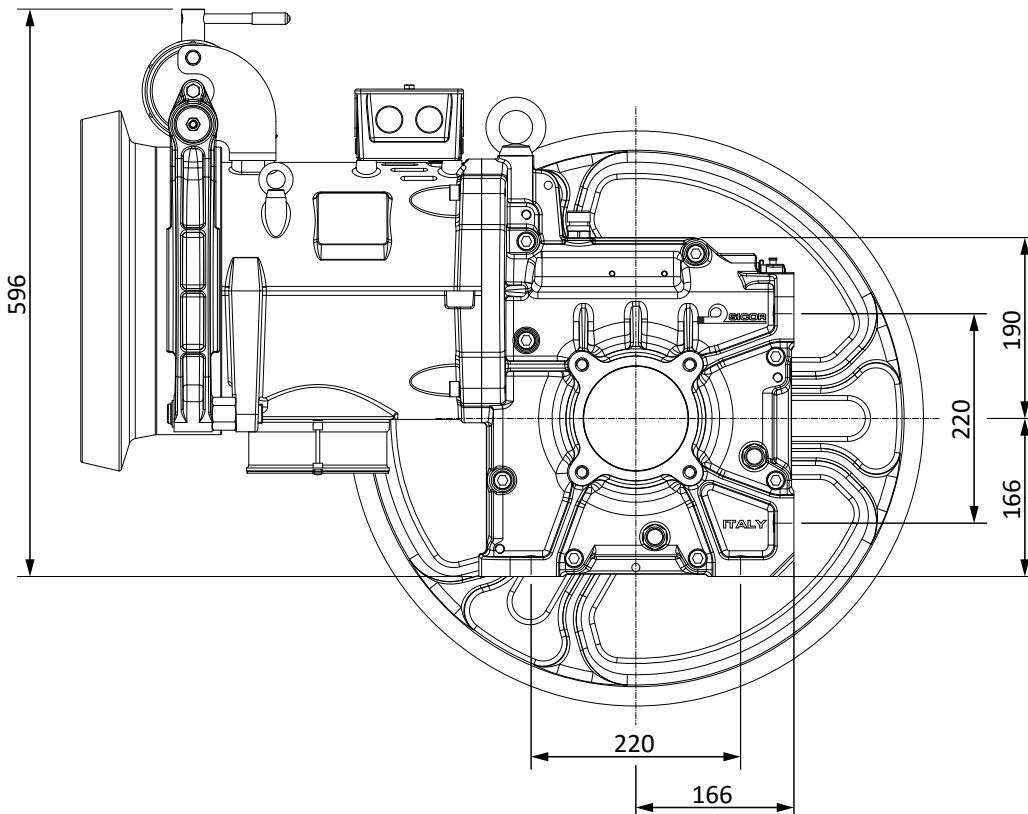
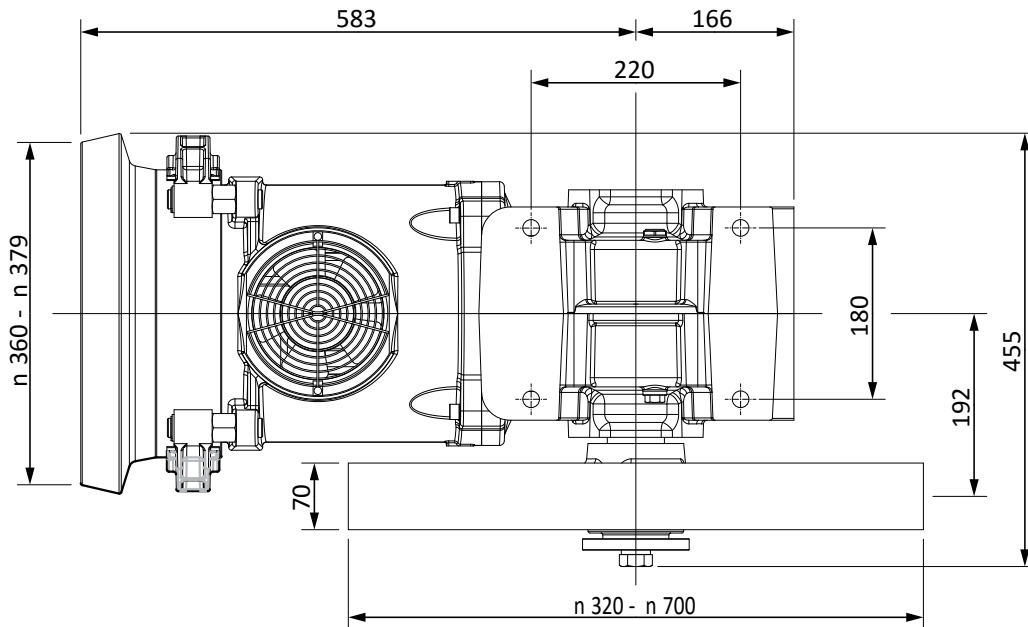

8. MOVING THE WINCH

WARNING

RISK OF CRUSHING,
IMPACT AND ABRASION



Personnel responsible for handling the winch must read the safety requirements in paragraph 6 of this manual and must wear work gloves and safety shoes.

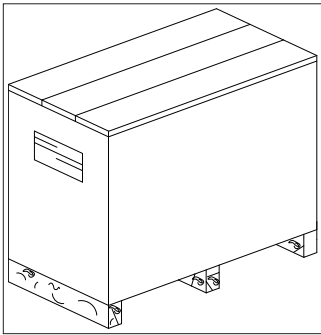
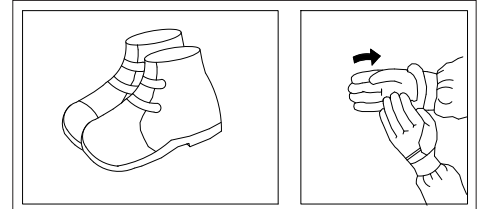

The winch is shipped by SICOR in crates or on a pallet wrapped in nylon film.



WARNING

Never move the crates by dragging them. Always lift them. Before removing the machine from its packing, place it as near as possible to its final position.

To move the crate, use a crane with ropes or an adequately sized forklift with long forks (see Chap. 7 "Technical features").

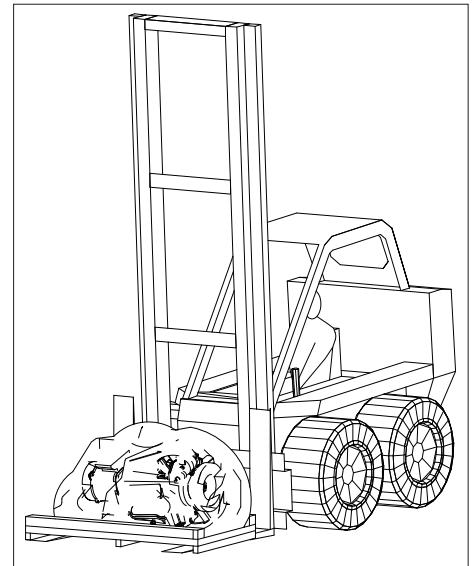

The forks must also be positioned as widely as possible to avoid tipping over.



If the machine has been shipped on a pallet, use an adequately sized load spreader when moving with a crane so that the lifting cables or chains are kept in a vertical position and do not damage parts of the machine.



During handling, remember the following points:

- proceed slowly
- do not lift the crate more than 30 cm off the ground unless obstacles are present.
- lay the crate on the ground slowly

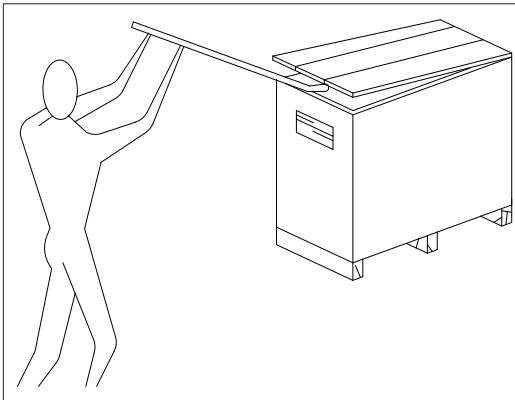
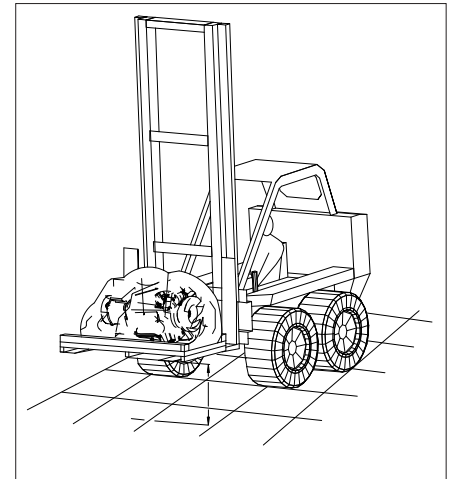

When unpacking the crate, start from the top and use suitable tools to open it. Afterwards, if the packaging is a crate, remove the side walls, removing the nails below from the pallet. When the machine is unpacked, **DO NOT DISPOSE OF THE PACKAGING IN THE ENVIRONMENT**, but rather reuse it or send it to a recycling company.

Once the walls of the crate have been removed, check that the supply corresponds with the shipping document and the order. If there is a discrepancy with the order, immediately notify SICOR or their agent. When necessary, proceed as described in paragraph 4 "General delivery notes".

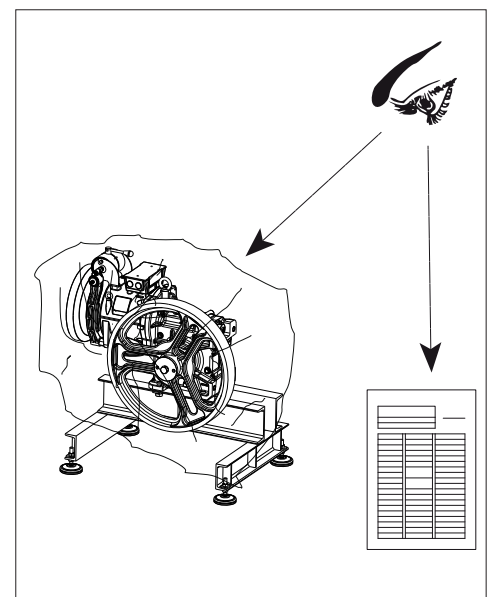

After slinging the winch, remove the screws that attach it to the pallet before lifting it.

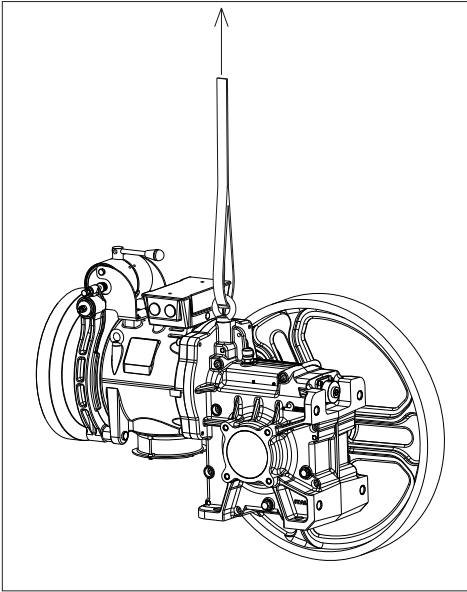

When moving the unpacked winch, use a crane or an adequately sized forklift with wide forks and a suspension-type lifting system connected to the eyebolts on the reduction unit and a non-metallic strap wrapped around the motor.



WARNING

Make sure there are no people exposed within the operating range of transport means with the winch (danger zone).



If the winch is stored for long periods, leave it on its pallet and make sure it is adequately protected (at least with a waterproof covering) to prevent oxidation of the internal or external parts of the machine.

Remember that the oxidation of shafts or other mechanical parts reduces its fatigue strength.

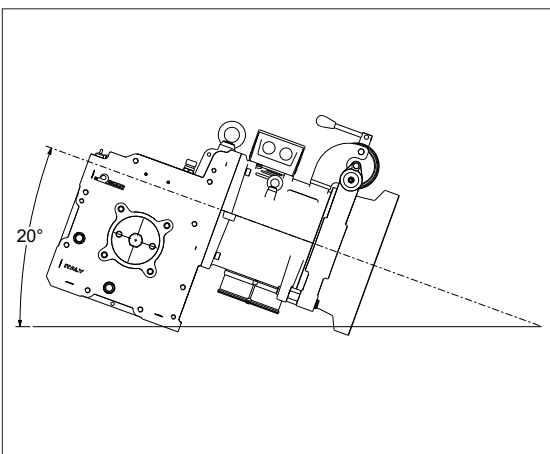
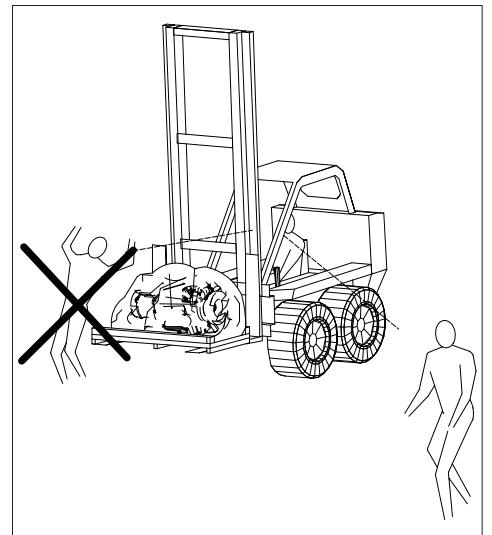

During the lifting and transport of the winch, make sure that it is not inclined, in relation to the horizontal position, at more than a 20 angle°, as the oil in the winch may leak. If the winch has to be transported in a slanted position exceeding these angles, the winch order must specify a request for supply with “oil separately”.

9. NOTES FOR INSTALLATION



WARNING

The location in which the winch is installed must have the following characteristics:

It must be dry and not dusty: this is essential to prevent electrochemical corrosion of mechanical parts and a high concentration of water in the lubricating oil. (clean the machine room before installing the machine).

The room must be ventilated: the room must have adequate openings or conditions that allow air circulation which dissipates the heat from the motor and the reduction unit.

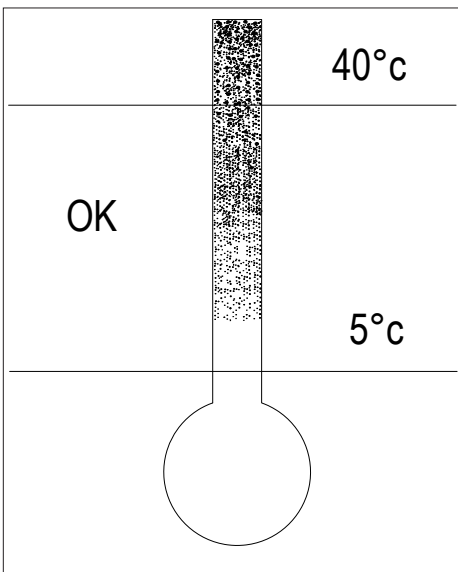
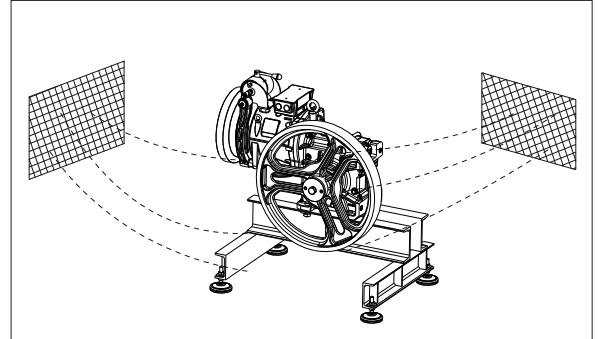

The room temperature must be between 5 °C and 40 °C. .
For other temperatures, contact SICOR.

The customer must make sure that the electrical system where the winch will be installed has suitably gauged cables, is correctly earthed and adequate power is installed.

9.1. MOTOR ROTATION INSTRUCTIONS



Before rotating the motor, you must:

- read the “Safety Requirements” chapter.
- disconnect the electrical power supply to the winch.
- Position the machine vertically so as not to change the alignment of the motor.
- Remove the pulley unit.
- Unscrew the locknuts so that there is clearance between the shoes and the drum/flywheel.
- Remove the 4 M10x40 fastening screws that connect the motor unit to the winch shaft.
- Turn the motor unit 180° in a clockwise direction (to adapt it to your requirements) until the holes where the screws were inserted are lined up with the holes on the winch shaft.
- Put the 4 M10x40 screws and washers back in place. Tighten to a torque of 50 Nm.

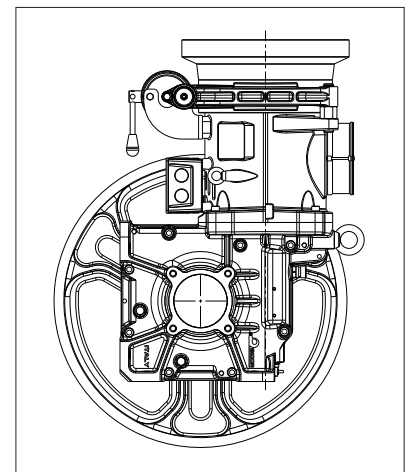
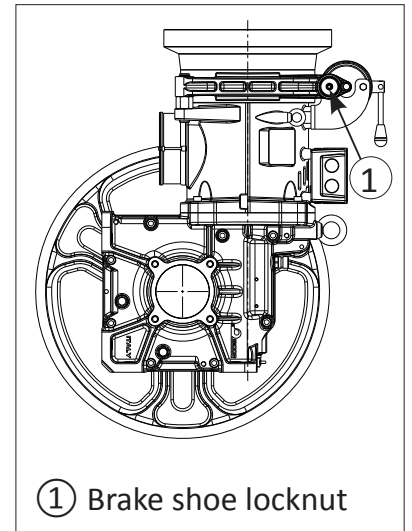

9.2. ENCODER INSTALLATION INSTRUCTIONS



Before installing the encoder, you must:

- read the “Safety Requirements” chapter.
- disconnect the electrical power supply to the winch.



If machines are ordered with the encoder option, they are supplied with all the parts needed to perform this task. The standard option includes an encoder driving pin.

- Unscrew the M3 screws that fasten the Lika C50 encoder plate.
- Remove the retaining plate and replace it with the one supplied by Sicor.
- Remove two of the 4 M6 fastening screws on the flange as shown in the diagram.
- Put the encoder in position by sliding it coaxially until the plate touches the thrust bearing flange.
- Put the M6 screws back in place by inserting them in the 7-diameter holes in the plate and tighten them to a torque of 10 Nm.
- Tighten the specially supplied encoder fastening dowel.

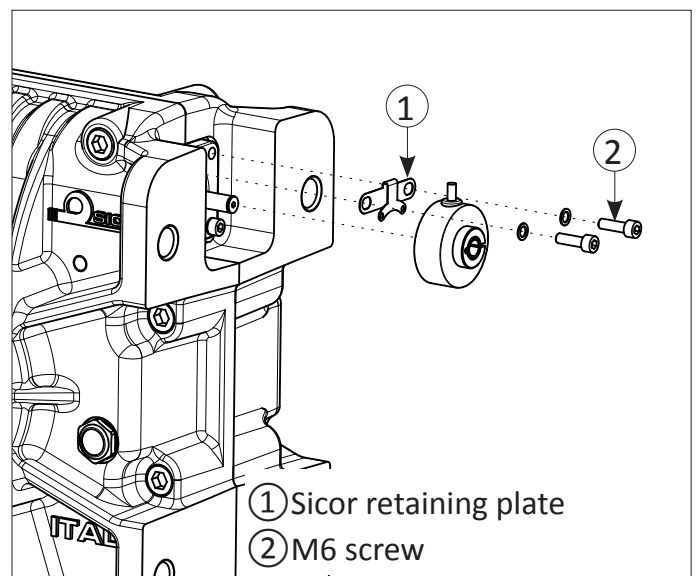
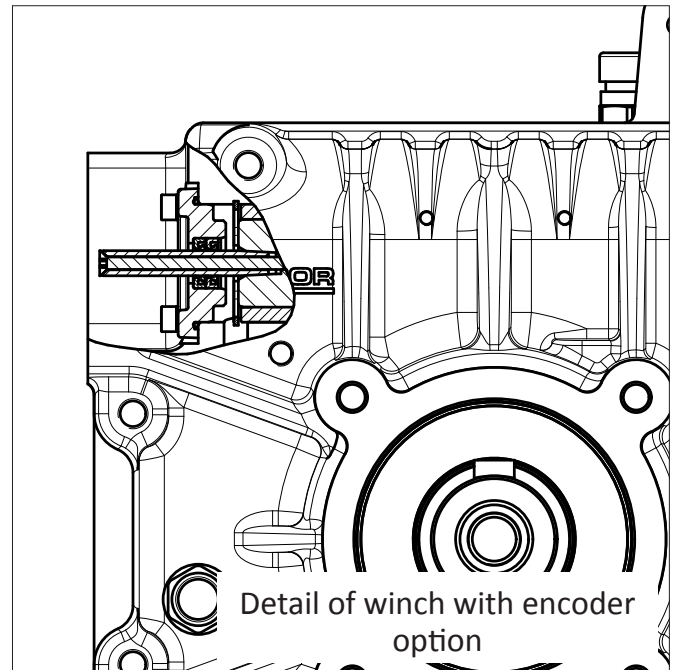

9.3. VENT PLUG POSITIONING (CODE:TAP0025)

The SH130G winch has a vent plug located on the reduction unit casing.

The vent plug acts as a safety valve. The pressure caused by the movement of the rotating elements within the gearbox is released via the labyrinth without allowing oil to spray out.

 The winch can be shipped in a left or right horizontal configuration and the vent plug is positioned as shown in the figure.

In the event of vertical positioning, there is no need to reposition the vent plug.

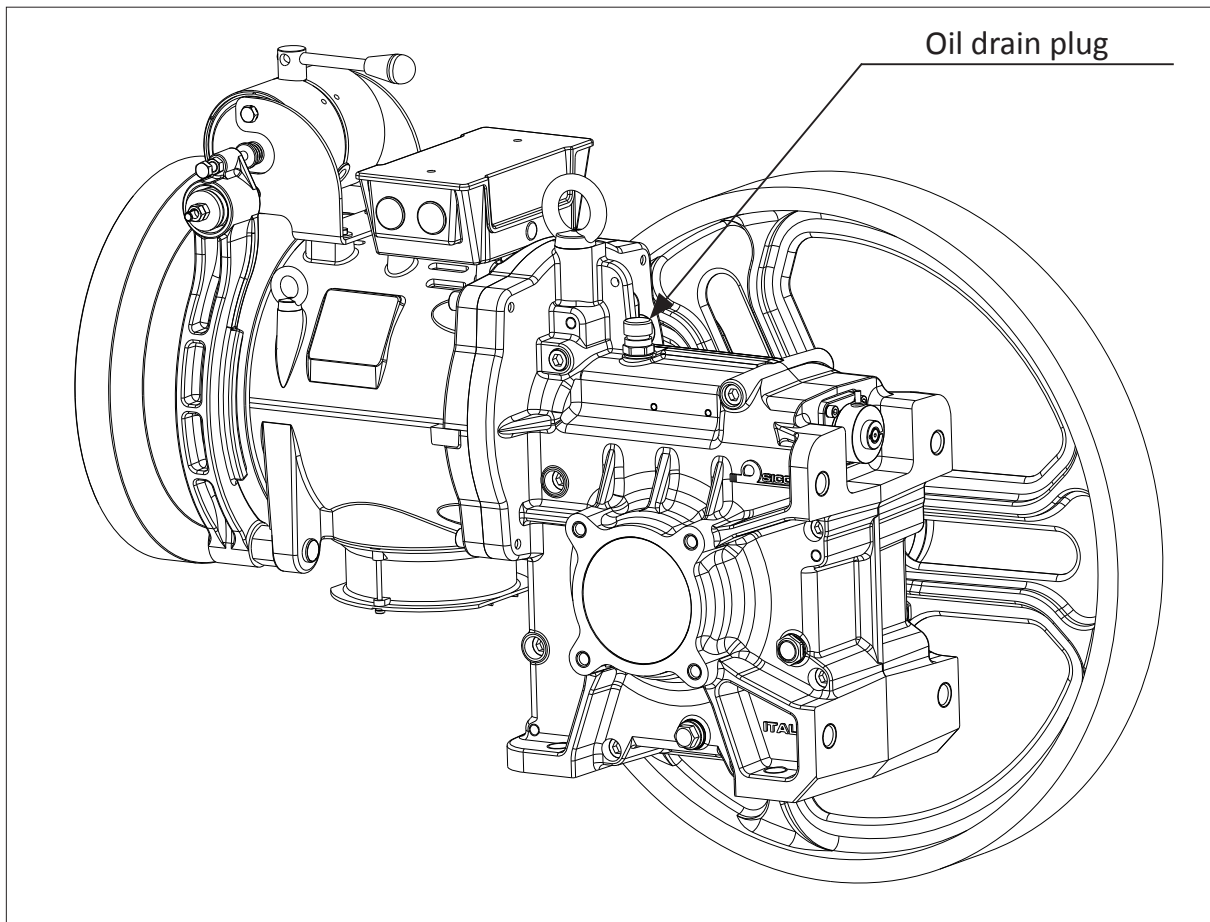

10. WINCH LUBRICATION

Shell Omala S4 WE synthetic oil is supplied with the winch. Ensure that the oil drain screw is tightly closed and check that the oil level is at the halfway point on the transparent gauge.

Shell Omala S4 WE is non-miscible with mineral oils and with most other types of synthetic lubricants. Be careful, therefore, to avoid mixtures forming during refill operations, both when draining and when topping up.

Mineral oils are not permitted for use in the machine.

The exclusive use of Shell Omala S4 WE oils is advisable.

Contact Sicor s.p.a. for information on using lubricants other than those indicated in this manual, and for instruction on the relevant replacement procedure.



Do not use other types of oil!

The SH130G winch requires 2,8 litres of oil.

10.1. CHANGING THE OIL

We recommend to change oil after 600 hours of winch operation, ensuring correct fluxing within the reduction unit.

Subsequent lubricant changes should be performed every 24/36 months depending on the conditions of use of the machine. If the oil temperature exceeds 85 °C (during intense use), the oil must be changed every 2 years. The oil must also be changed if it is contaminated by other substances (e.g. water or topping up with unrecommended oil).

To change the oil:



- read the "Safety Requirements" chapter.
- disconnect the electrical power supply to the winch.
- wait for at least one hour from machine shut-down so that the oil in the winch cools down.

- ① Oil level
- ② Oil filling
- ③ Oil discharge

Right horizontal winch

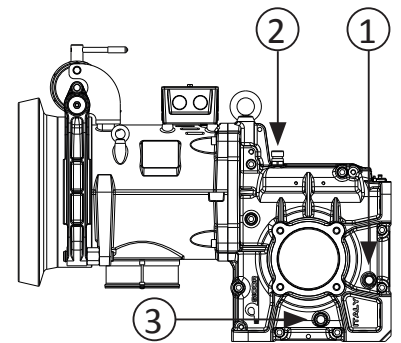

Vertical winch

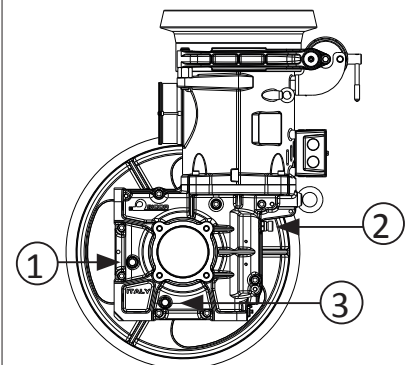

Left horizontal winch

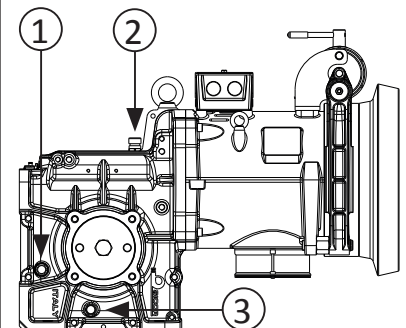

- clean the area around the oil filler cap on the winch to prevent from entering dirt or deposits which could cause serious damage to the machine
- remove the oil filler cap
- place a container under the drain plug to collect the used oil
- unscrew and remove the drain plug and wait a few minutes for the tank to drain completely.
- clean the drain plug and the area where it is housed with a cloth; tighten the plug and make sure to also insert the washer; tightly fasten.
- thoroughly clean the surface of the new oil container, the filler cap and the area surrounding it to prevent dirt or deposits entering the winch. Failure to comply with these instructions may cause serious damage to the machine.
- pour the oil through a clean spout until the level on the transparent gauge is reached.
- replace the filler cap.

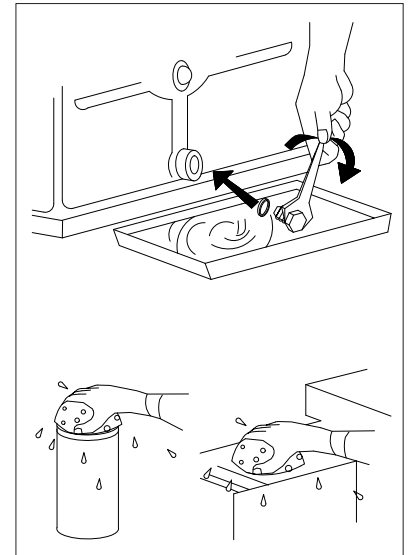

DISPOSAL/RECYCLING



Disposal must take place in line with the highest industry standards and in full respect of environmental considerations, in accordance with the legal regulations in force.

10.2. CHECKING THE OIL LEVEL

Checking the oil level can be done immediately by checking the transparent gauge. If the oil level is low, top up using the same type of oil that is in the winch. To top up, follow the above steps.



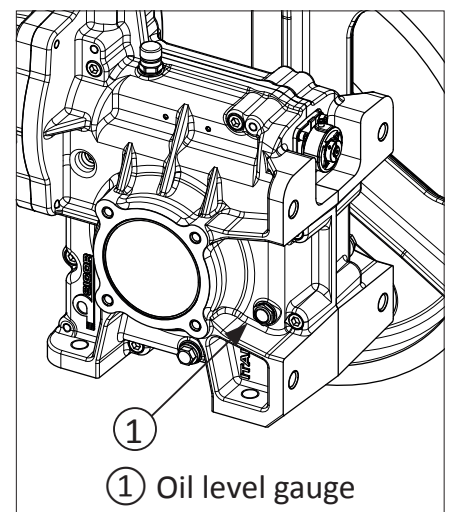

The oil level must be checked when the machine has been off for at least 30 minutes.



11. ELECTRICAL CONNECTIONS

Before making the electrical connections, installers **MUST** make sure that the mains voltage matches the technical specifications and the data on the winch identification plate.

	All electrical connections must be made with the main switch in the OFF position.
	Make sure that the rated supply voltage is maintained at all times.

If they match, connect the electric motor.

1 ELECTRIC MOTOR

Using the wiring diagram (which can be found in the motor terminal box), make the electrical connections and make sure that you connect the phases and earth correctly.



IMPORTANT NOTE

Any thermistors on the motor **MUST BE CONNECTED TO A SPECIFIC RELAY ONLY.**

Incorrect connection of the thermistors will burn them out immediately.

2 AUXILIARIES

Connect any auxiliaries by referring to the wiring diagram placed under the terminal box cover or enclosed with this manual.

Check that the tension of the installed brake corresponds to that of its dedicated charger, check that the coil connections correspond to those indicated in the diagram under the terminal board cover. The installer is responsible for providing a suitable surge suppressor to protect the brake coil.

Please also remember to check the fan voltage and power frequency.

After connecting, close the terminal box.



In any motor configuration, always connect the correct voltage ($V\sim$) to terminals 1, 2 of the fan.

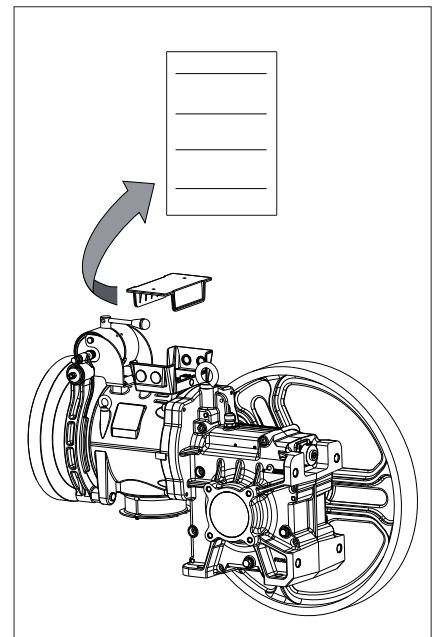
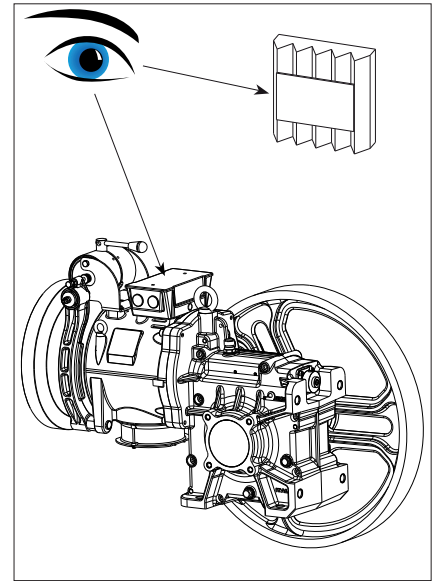

12. WIRING DIAGRAM

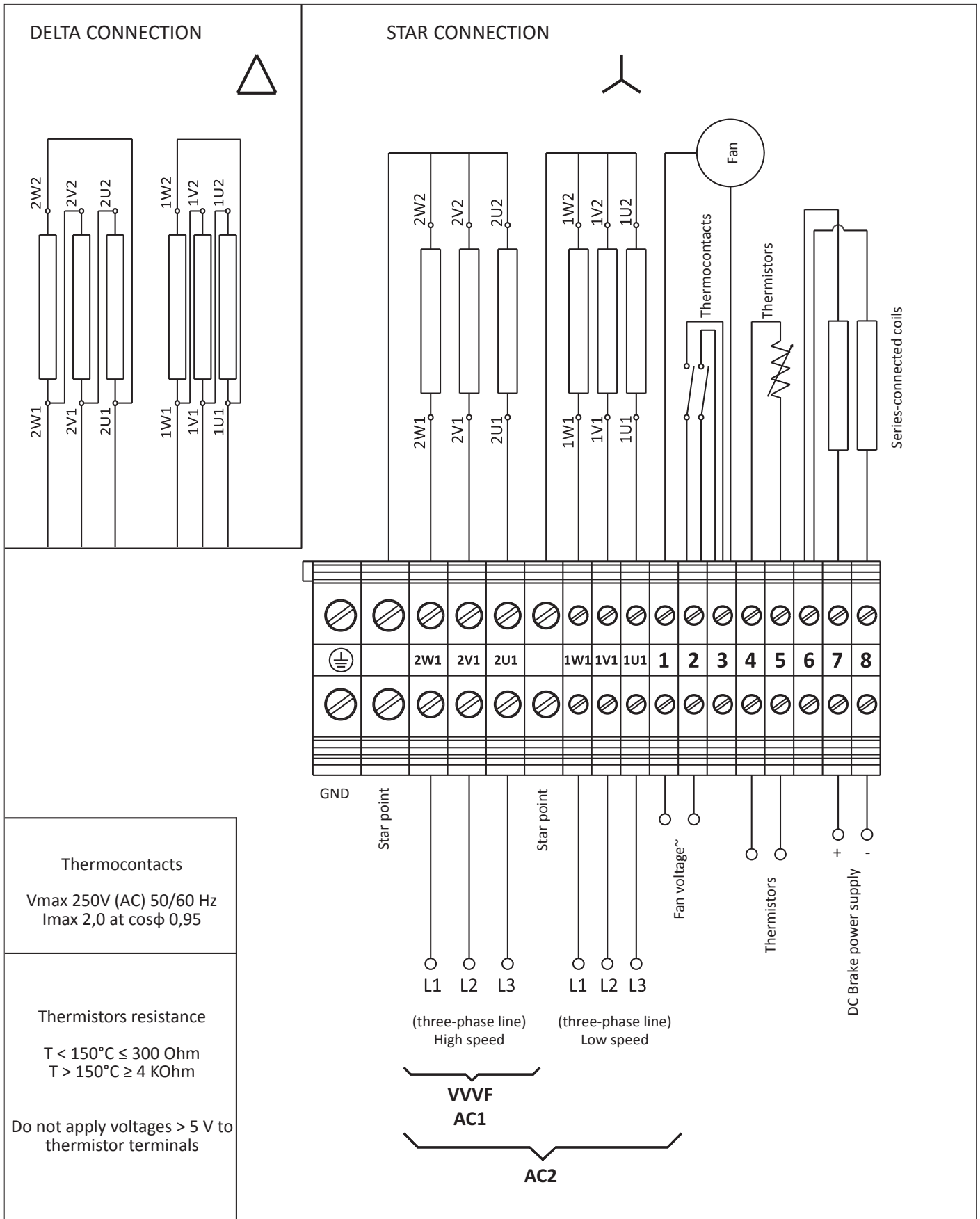

13. STARTING THE WINCH

Before placing the cables on the pulley:

- Make sure that the reduction unit has been filled with oil.
- Check that the electric connections have been made correctly and that the terminal box covers have been put back into position.
- After turning the flywheel a few turns by hand, start the motor at high speed for a few seconds in one direction and then, after a short pause, in the other.
- Wait a few minutes (5 minutes minimum) for the oil to flow along the channels and lubricate the rotating parts.
- Make sure the brake releases correctly as described in the sheet enclosed with the winch.
- Run the machine without load for 3 ÷ 5 minutes at high speed and make sure no anomalies occur. If malfunctioning occurs, recheck the electrical connection, supply voltage, absorbed current and/or the way the winch is clamped to its base. If you are uncertain about anything, contact SICOR.
- Make sure that the flywheel always turns freely. Repeat the last step and recheck.
- At this point, place the cables on the pulley and perform the first operations.
- Make sure that the counterweight is the correct size and does not overload the winch and the motor.

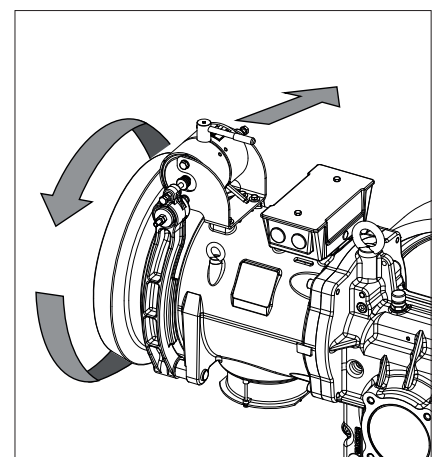
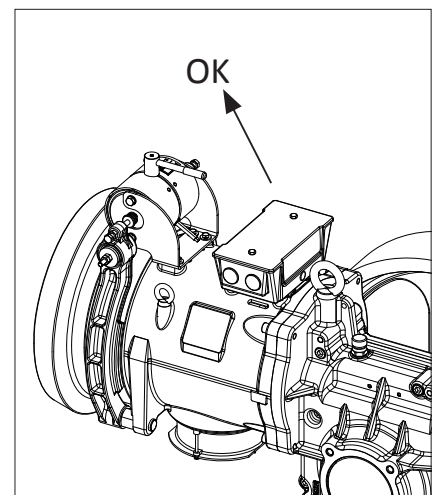
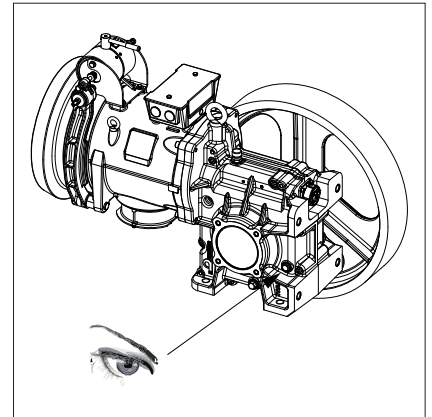

WARNING

Never operate the winch under load when the base fastening screws are not tight! This may cause serious damage to the machine!

**IMPORTANT**

When installing the lift, do not operate the winch for long periods at low speed.



When the winch operates for long periods at low speed, the machine supports are not lubricated properly and may seize up unexpectedly.

To ensure proper lubrication, always start the winch at normal operating speed each time work is begun and then run at high speed every half hour.

START-UP/SHUT-DOWN

The customer is responsible for the procedures, instructions and wiring diagrams for the start-up and shut-down of the winch.



NEVER USE THE WINCH FOR PERFORMANCES ABOVE THOSE INDICATED IN THE TECHNICAL CATALOGUE.

14. DISPOSAL/RECYCLING

Disposal must take place in line with the highest industry standards and in full respect of environmental considerations, in accordance with the legal regulations in force.

15. MAINTENANCE

Before carrying out any maintenance work, **MAKE SURE YOU HAVE** read paragraph 6 "Safety requirements" in this manual.

Installing and/or maintenance may only be done by competent personnel, authorised to access the machinery and having the necessary equipment and instruments.



WARNING

Before starting any installation and/or maintenance work, attention must be given to the safety requirements given below in order to avoid accidents and damage to the product components:

- Make sure you have the appropriate personal protection equipment (helmet, body harness, gloves, safety shoes).
- Always secure equipment and other objects to avoid them accidentally falling from a height.
- Make sure that the power has been disconnected before working on electrical equipment.
- Only install the electrical system and/or the connections once you have read the relative instructions.
- Before starting installation, see if there are any structural and space limitations where the installation / maintenance work will be carried out.
- It is advisable to consider where and when you will be operating and which assembly/maintenance procedures you will use.
- Take account beforehand of all significant limitations that may regard the various operation phases and do not start work without first evaluating the consequences.



Installers/maintenance personnel must provide a maintenance plan in relation to the use characteristics of the winch.

Routine maintenance of the winch is limited to:

- Lubrication of the winch (see page 18)
- General cleaning of the winch
- Brake adjustment
- Assessment of wear and tear of brake linings
- Assessment and checking of wear and tear of pulley grooves



Some reduction ratios have a partial degree of reversibility, in such conditions the opening on the machine brake can generate cab and counterweight movement.

Before manually opening the brake therefore, ensure that the counterweight is resting on the shock absorbers and that the cab cannot be accessed.

15.1. PRE-ADJUSTMENT OF THE BRAKE

The winches are normally supplied with the brake that requires some adjustment based on the characteristics of the system. The braking distance depends on the compression of the brake's springs; the springs need to be adjusted to obtain the braking torque of the braking system that is suitable for the system, and in compliance with EN81.20-50 (See chart).

If an additional adjustment is required, follow the instructions reported in the following chapter.

* See chapter "CHECKING THE STROKE"

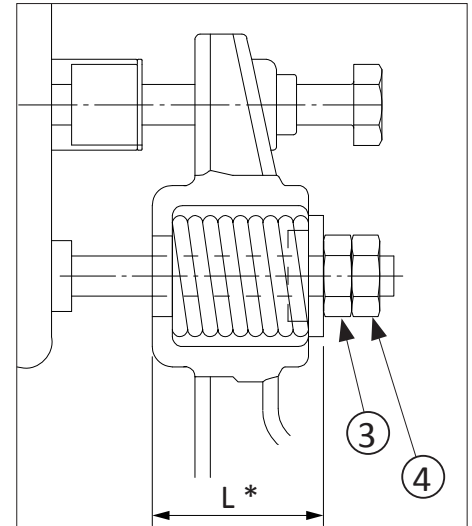

15.2. BRAKE ADJUSTMENT

The brake has two separate magnets so that the shoes operate independently of each other.

Usually the brake shoes must open with the shortest stroke possible, but without showing any friction on the brake's drum under the normal winch working condition.

Check periodically the status of wearing of the brake's shoes' friction material. In case of wear, proceed with the adjustment operations in compliance with what's provided in the following chapters.

During each adjustment intervention, make sure that between the opened brake's shoe (winch free to rotate) there's a space equal to 0.1-0.15 mm in the lining's lower part, by verifying with a calibrated spacer.

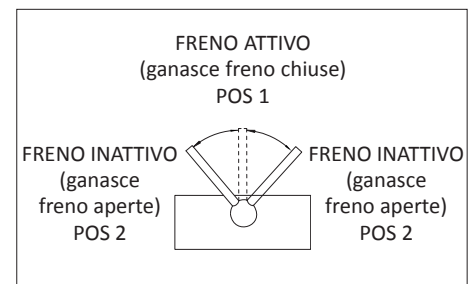

15.2.1. STROKE ADJUSTMENT

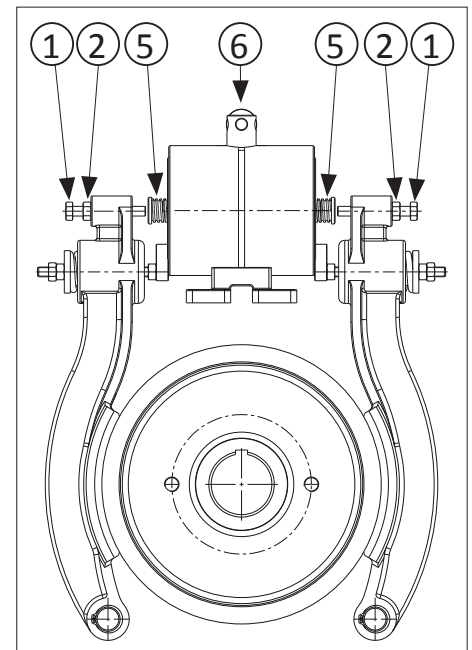

- Loosen the locknuts (2) on both the brake shoes and unscrew the adjusting screw (1) leaving a clearance of 4-5 mm between the screw and the electromagnet pin (5),
- turn the brake opening lever (6) to the "open" position,
- tighten the adjusting screws (1) by hand until they are flush with the electromagnet pin (5),
- turn the brake opening lever (6) to the "closed" position and tighten the adjusting screw half a turn (equal to about 0.1-0.15 mm in the lining's lower part) against the electromagnet pin,
- tighten the locknuts (2).

15.2.2. CHECKING THE ADJUSTMENT

Move the cab up and down and listen to the noise level. The stroke is correctly adjusted if the brake lining does not touch the brake drum while the lift is moving and no noise is heard when braking.

15.2.3. ADJUSTMENT OF BRAKING TORQUE

The braking distance depends on the compression of the brake springs, which are adjusted to suit the characteristics of the equipment and in conformity with EN81.20-50 .par. 5.9.2.2.2.1. where applicable.

It must be taken into consideration that following wear to the lining, the springs compression level tends to decrease, reducing its braking capacity. In this case, increasingly the pre-load of the spring alone is considered to be an error, given the fact that the operation must be accompanied by the adjustment of the stroke (refer to paragraph 14.2.1).

If this procedure is not done correctly, the brake system may not work properly.

The braking torque is adjusted when the cab is empty.

- Repeat the same steps for both brake shoes:
- Unscrew the locknuts (4).
- Check the braking distance.
- If the braking distance is too short, loosen the spring by turning the nut (3). If it is too long, tighten the spring again by turning the nut (3).
- Once the braking distance has been adjusted correctly, check that the springs are of the same length. Secure using the locknut (4).

When the adjustment is complete, it is important to check that the springs are not fully compressed and that the provisions set out in EN81.20-50 par. 5.9.2.2.2.1 have been verified. In the event that the springs are fully compressed, bring them back to the L level shown in the Figure and proceed again with the stroke and braking torque adjustment cycle.

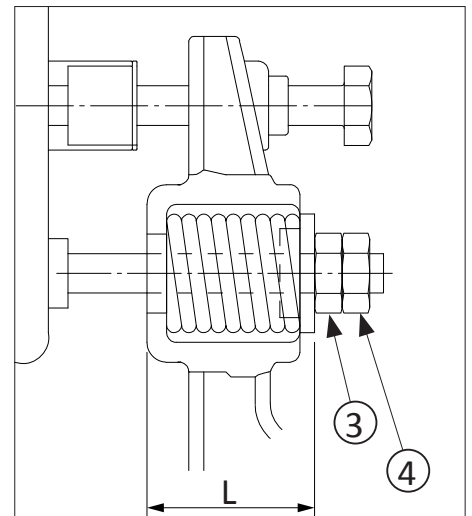

15.3. CHECKING THE STROKE

Make sure that the brake opening lever (6) is in position (brake closed). Manually press the electromagnet pin (5) right down and then measure the clearance between the adjusting screw (1) and the electromagnet pin (5). If it is < 0.5 mm, the stroke must be adjusted immediately.

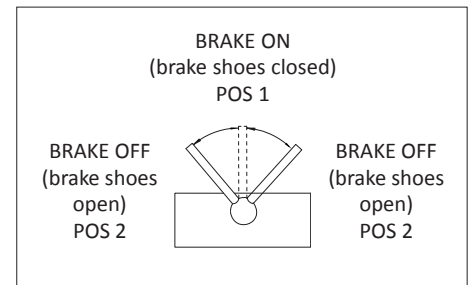

Braking torque \varnothing D 276 mm

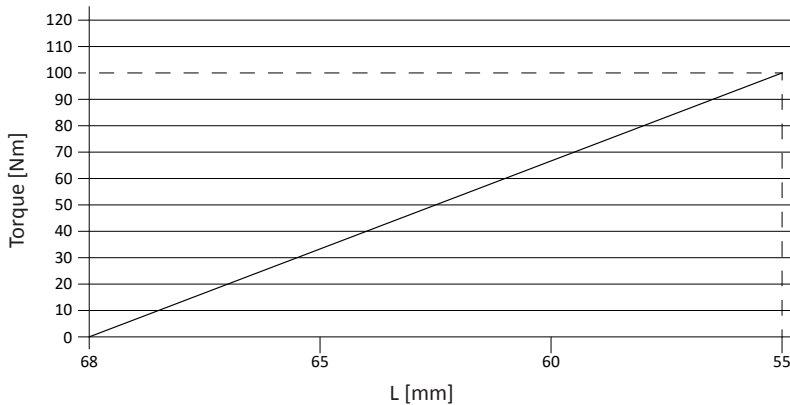

Braking torque \varnothing D 302 mm

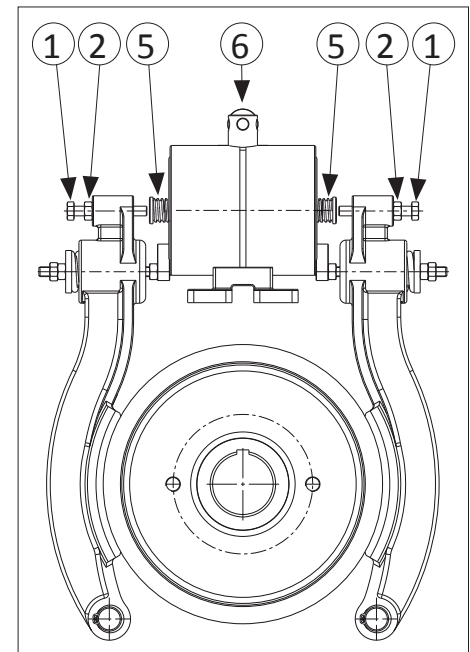
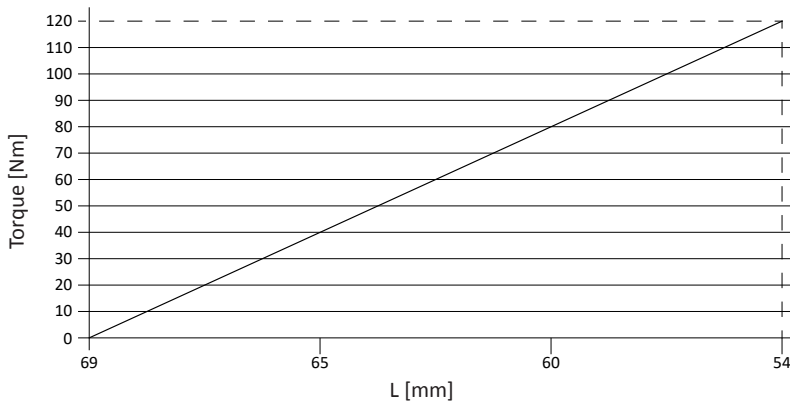

Machine type	D (\varnothing Brake drum) [mm]	L (minimum) [mm]	Maximum braking torque [Nm]	Brake lining friction coefficient [Nm]
SH130G	276	55	100	0,44
SH130G	302	54	120	0,44

15.4. COMPULSORY MAINTENANCE OPERATIONS

It is necessary to plan the below listed checks according to the minimum schedule indicated in the table. In any case is responsibility of the elevator maintenance manager evaluate the necessity to increase the frequency of check in case of intense duty.

Check	Frequency
Oil level	6 months
Adjustment of opening of brake shoes and friction material thickness check *	6 months
Wear and tear of pulley grooves	6 months
(Acoustic) of condition of bearings	6 months
(Acoustic) of presence of abnormal noise levels	6 months
Gear backlash measured as shown in the figure. (First ensure that there is no axial play of the screw)	12 months

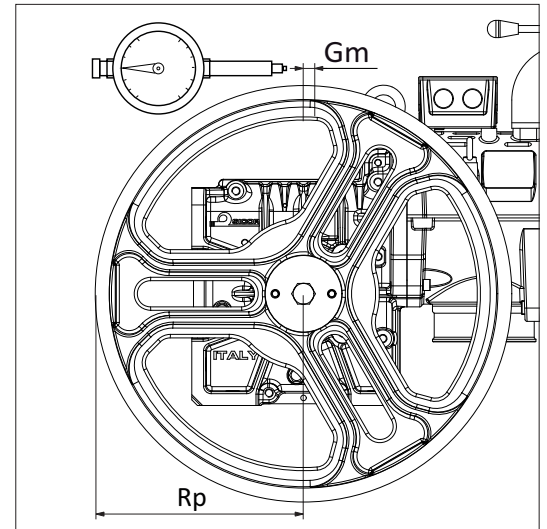

$$G = Gm \times \frac{Rpr \text{ [mm]}}{Rp \text{ [mm]}}$$

R.R.	Rpr (mm)
52/1	111,2
43/1	110,4
37/1	109,6

* The nominal thickness in 6 mm, brake shoes must be replaced before the minimum thickness of the friction material reaches 2 mm.

Rpr = pitch radius of gear

Rp = radius of pulley

Gm = measurement of pulley clearance

When the "G" gear play exceeds the "GL" value, as indicated below, the gear must be replaced because it no longer offers the required level of safety.

	Reduction Ratio		
	52/1	43/1	37/1
GL (mm)	0,73	0,87	1,01

16. MANUAL EMERGENCY OPERATING

16.1. WARNINGS



Manual emergency manoeuvre is a dangerous task. It can be used to move the cab excluding all the plant safety contacts. For this reason, anyone who performs this operation must have been carefully trained by specialised personnel and must be aware of the risks involved.

Assistance in the event of an emergency must only be provided by expert, specially trained personnel. All the operations performed in the event of an emergency must strictly follow the instructions in this manual. A copy of this document must therefore be kept near the storage area and be easy to access if necessary.

In the event of an emergency entailing manual manoeuvres strictly observe the following instructions:

- Follow local safety requirements.
- Do not neglect the safety of passengers at risk in any way.
- Do not put them at risk in any way.
- Make sure that their actions do not create hazardous situations for third parties.
- Communication with any passengers in the cab must be established as soon as possible in order to reassure the people present. This can help to establish the position of the cab in the well more precisely.
- Before each intervention, first inform the passengers of what you intend to do.
- After completion of work, make sure there are no problems with normal operating of the plant.

16.2. INSTRUCTIONS FOR AN EMERGENCY MANUAL MANOEUVRE



Manual emergency operating is a dangerous task

It can be used to move the cab excluding all the plant safety contacts.

For this reason, anyone who performs this operation must have been carefully trained by specialised personnel and must be aware of the risks involved.



For correct emergency manual operating, carefully follow these instructions.

- Check that all lift doors of the floors are closed and they cannot be opened in any way.
- Check that the cab is at floor level. If it is not, do the following.
- Place the main switch on the control panel to the OFF position.
- Reassure the passengers in the cab, explaining to them exactly what you intend to do.



Passengers must not try to force open the cab doors or try to get out of the cab.

- Check that the operating conditions of the main brake and winch are safe for moving the cab.



To see if the main brake on the winch is working properly, check:

- if the brake shoes are broken
- if the brake linings are damaged which limits the contact surface
- if contact with the braking surface is uniform

- Check rotation direction of the winch for the cab movement manoeuvre.



If the winch and/or the main brake are out of use or the safety is inserted, perform the rescue procedure and ensure that the cab is secure by using a special device suitable for the type of plant, place and operating conditions.

- Manually block rotation of the winch's flywheel.
- Release the main brake using the special manual lever (POS 2).
- Begin manual operating to move the cab to the required floor by manually rotating the flywheel in the right direction.
- Release the manual release lever of the main brake on the winch and check that it goes back to the off position (POS 1).
- Open the cabin doors and help the passengers.
- Close the cabin and floor doors.
- Check that all lift doors of the floors are closed and they cannot be opened in any way.



Never loosen the tension of the brake springs to make manual emergency operating easier.

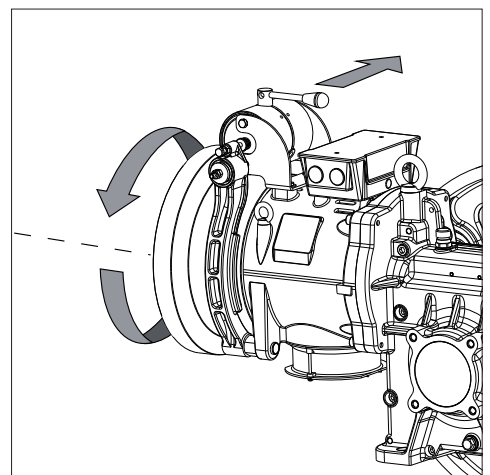
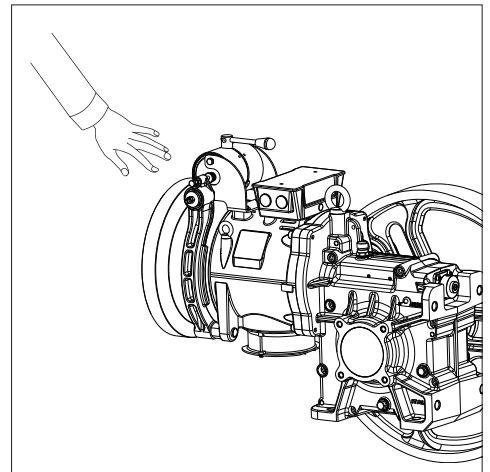
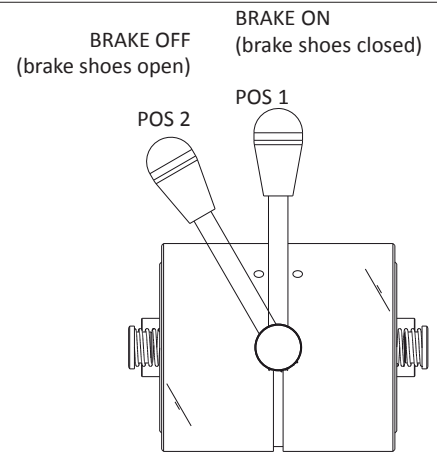

If the winch is fitted with a slow shaft brake (SSB), follow the procedures described in the relevant manual.

SICOR S.p.A.

Head Office and Production Centre

Viale Caproni 32 (Industrial Area) 38068 Rovereto (TN) Italy

Ph.. +39 0464 484111 Fax +39 0464 484100

www.sicor-spa.it info@sicor-spa.it

