

OPERATION AND MAINTENANCE MANUAL

# SH190 SSB

COD.: MUM0208 REV. 02

english

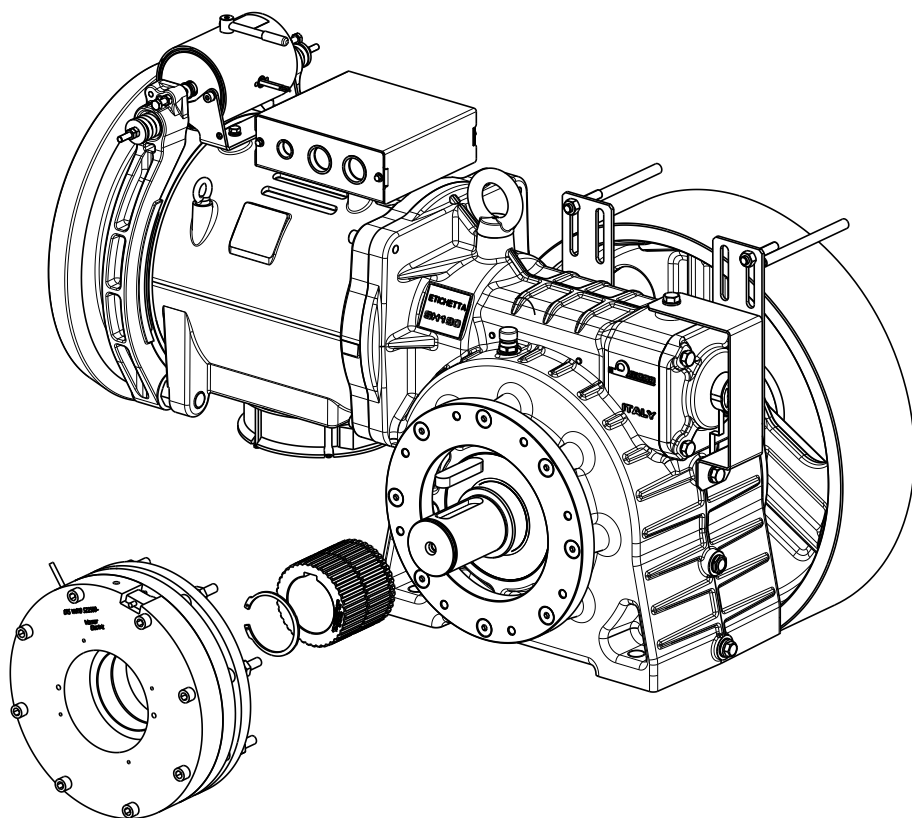

SICOR S.R.L.

Head Office and Production Centre  
Viale Caproni 32 (Industrial Area) 38068 Rovereto (TN) Italy  
Ph.. +39 0464 484111 Fax +39 0464 484100  
[www.sicoritaly.com](http://www.sicoritaly.com) [info@sicoritaly.com](mailto:info@sicoritaly.com)

 **SICOR**  
DRIVING THE FUTURE



**INDEX**

1.	GENERAL INDICATIONS .....	2
2.	PROJECT DESCRIPTION .....	3
2.1.	LIABILITY AND WARRANTY .....	3
3.	SSB PROJECT .....	4
3.1.	ELECTROMAGNETIC BRAKE DEVICE .....	5
3.2.	BRAKE SUPPORT .....	7
4.	OVERALL DIMENSIONS .....	10
5.	SSB SUPPLY .....	11
5.1.	COMPLETE SSB SH190 KIT .....	11
5.2.	SSB SH190 WINCH OPTION .....	11
5.3.	COMPLETION KIT .....	11
5.4.	ACCESSORIES .....	11
6.	INSTALLATION AND MAINTENANCE .....	12
7.	SAFETY PRECAUTIONS .....	13
8.	TRANSPORTING AND HANDLING LOADS .....	13
9.	INSTALLING THE COMPLETE SSB KIT .....	14
10.	COMPLETION KIT INSTALLATION .....	15
11.	ELECTRICAL CONNECTIONS .....	16
11.1.	BRAKE .....	16
11.2.	MICROSWITCH .....	17
11.3.	SSB POWER SUPPLY .....	17
12.	STARTING THE WINCH .....	18
13.	CHECKS AND MAINTENANCE WORK .....	19
13.1.	SSB BRAKE AIR-GAP ADJUSTMENT .....	19
13.2.	SSB BRAKE MICROSWITCH ADJUSTMENT .....	20
14.	MANUAL EMERGENCY OPERATING .....	21
14.1.	WARNINGS .....	21
14.2.	INSTRUCTIONS FOR AN EMERGENCY MANUAL MANOEUVRE .....	21
15.	ANNEXES .....	24
15.1.	TÜV CERTIFICATION FOR SH190 SSB WINCH .....	24

## 1. GENERAL INDICATIONS

The purpose of this manual is to give a detailed description of the SSB project (Slow Shaft Brake) characteristics for the SH190 winch and its usage, maintenance and emergency requirements by way of texts, drawings and technical data sheets.

Property of this manual is reserved and it is forbidden to reproduce it, even partially, without the written authorisation of Sicor S.p.A..

This manual is an integral part of the SSB supply and must be kept in a protected place that is also easy to access in the case of need.

For any problems or if this manual is lost or damaged please refer to:

Registered Office and Factory  
Viale Caproni N°32 (Zona Industriale)  
38068 Rovereto (TN) – Italy  
Phone +39-0464 484 111 Fax +39-0464 484 100  
[www.sicor-spa.it](http://www.sicor-spa.it)  
[info@sicor-spa.it](mailto:info@sicor-spa.it)

## 2. PROJECT DESCRIPTION

The SSB project is a device to protect against excess speed of the cab when ascending and/or uncontrolled movements upwards or downwards with the doors open for traction drive lifts (EN 81-80, 5.9.4).

The device consists of an electromagnetic clutch brake connected directly to the pulley shaft by means of a tongue and groove system and constrained to the winch with a bolted support. Assembly of this type of brake requires a particular winch configuration so the choice has to be made when placing the order for the machine.

This device helps meet safety requirements for existing plant and is manufactured in compliance with current regulations, in particular:

Machinery Directive 2006/42/EC, 2014/33/UE, EN 81-20, EN 81-50, UNI EN 12100, [95/16/EC, EN 81-1]

### 2.1. LIABILITY AND WARRANTY

The SSB must be installed on the SH190 winch by qualified personnel in compliance with these instructions.

Bear in mind that this manual can in no way take the place of the experience of lift installers, maintenance engineers or those who repair lifts.

The responsibility for training and refresher courses of workers lies with the company assigned to install and service the lift.

Sicor S.p.A. does not accept any responsibility for damages caused by an improper use or for damages deriving from the result of actions different from those described in this manual and that can compromise the characteristics of the product.

The product is covered by a 24-month warranty that starts from the date of dispatch.

The product warranty can be cancelled if parts or components are installed different from those described in these instructions.

For the technical details about the components to buy, this manual in no way takes the place of the actual instructions provided with the subject parts and enclosed with this document.

## 3. SSB PROJECT

The SSB device installed on SH190 type winches consists of the following components (Figure 1) and in particular:

- Winch with extended pulley shaft
- Electromagnetic brake device
- Brake support
- Accessories
  - SSB power supply
  - Extended shaft protection (only for the SSB option supply)
  - Hexagonal wrench bracket and SSB release screws

Figure 1 – SSB-SH190 winch assembly

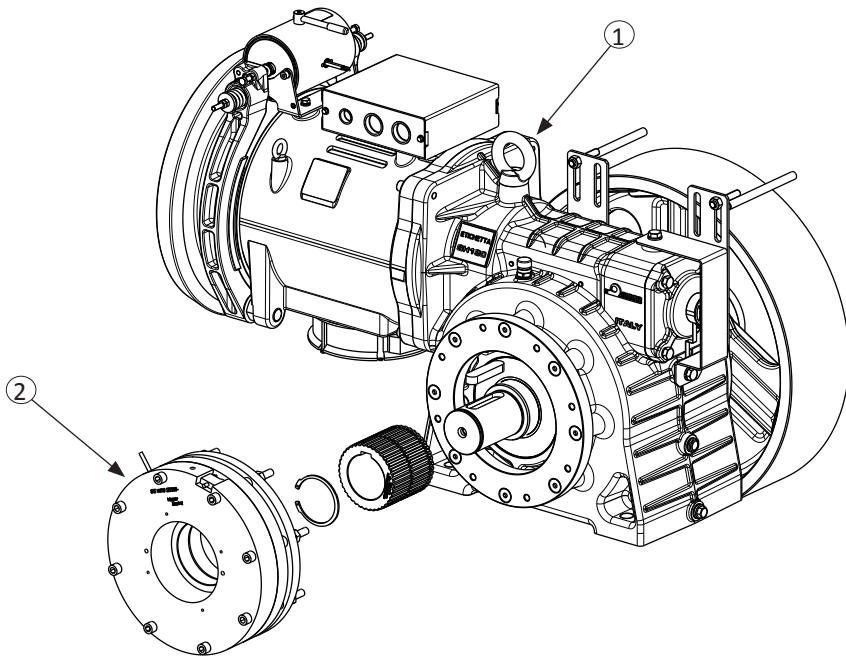

- ① SH190 Winch
- ② SSB brake group

## 3.1. ELECTROMAGNETIC BRAKE DEVICE

The electromagnetic brake (Figure 2) is the physical braking device installed on the drive pulley shaft. It consists of an electromagnetic body, a clutch disc and a hub with knurled coupling. This device is open (slow shaft of the free winch) when powered with current or closed (braked slow shaft) when there is no power supply. It is supplied with a mechanical blocking device (transport screws with red coloured head) that must be removed before starting the device. The following table gives the technical features of the electromagnetic parking brake (Table 1).

Figura 2 – Warner brake, type ERS VAR10-SZ2500/3000 (COD.: GEN0227), exploded drawing of the components and complete unit

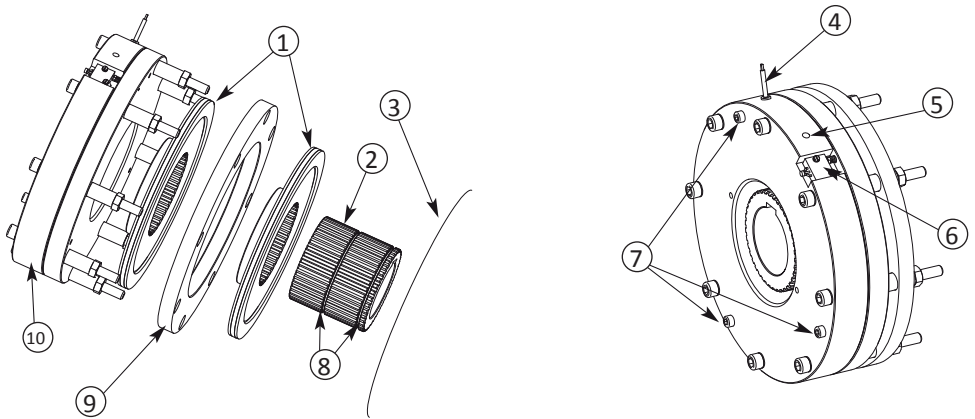

- ① Clutch disc projecting on the flange side
- ② Hub
- ③ Mounting flange (customer)
- ④ Coil cable
- ⑤ M10 thread
- ⑥ Microswitch
- ⑦ Transport screws
- ⑧ Hub with O-rings
- ⑨ Term disc
- ⑩ Magnet

Table 1 - Technical features of the Warner ERS VAR10-SZ2500/3000 brake.

### TECHNICAL SPECIFICATIONS

Brake type	Warner ERS VAR10-SZ2500/3000
Torque [Nm]	2500
Rated voltage [Vdc]	103,5
Over-excitation voltage [V]	207
Rated current [A]	0,76
Over-excitation current [A]	1,52
Resistance [Ohm]	136
Rated power [W]	79
Over-excitation power [W]	315
ED [%]	60
Weight [kg]	60
Maximum rotation speed [rpm]	250
Air gap [mm]	0,45 + 0,1 / - 0,05
Max. air gap [mm]	0,7
Operating temperature [°C]	-25 / 40°C
Protection class (electrical) [ ]	IP54
Level of insulation [ ]	Class F (155°C)
Microswitch	--
Voltage [Vdc]	24
Current [mA]	10 - 100
Estimated life [cycles]	50.000.000

The specifications given in the table comply with the Warner-Electric-Europe technical documentation.



## 3.2. BRAKE SUPPORT

The brake support is the adaptor used to install the SSB emergency brake on a SH190 winch. It comprises a mounting flange (CODE: PIS0083) with threads for anchoring the brake body. This flange is bolted directly on to the main body (shaft) of the winch (Figure 3).

Figure 3 – Electromagnetic brake support, front flange (CODE: PIS0083).

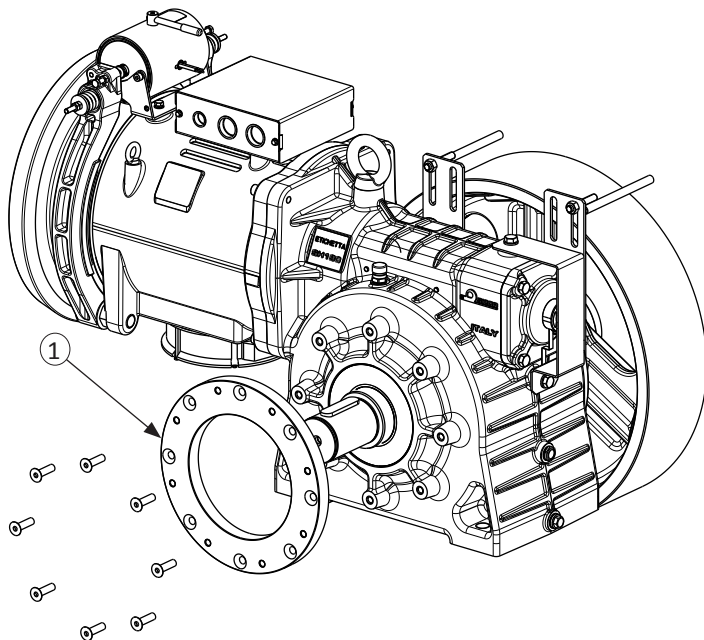

① SSB brake support flange code PIS0083

## 3.3. ACCESSORIES

Warner Electric Europe power supply (CODE: GEN0122) for electromagnetic brake (Figure 4). The following technical characteristics comply with the specifications given in the Warner Electric Europe manual, code: SM383 rev.:03/06 (Table 2).

Table 2 – technical features brake power Warner CODE: GEN0122

Supply voltage [VAC]	max. 230
Frequency [Hz]	50/60
Output voltage [VDC]	103.5
Current [A]	max. 4
Power output [W]	max. 414
Maximum power permitted (t=2s) [W]	828

Figure 4 - SSB Brake power supply CODE GEN0122 and overall dimensions of the component.

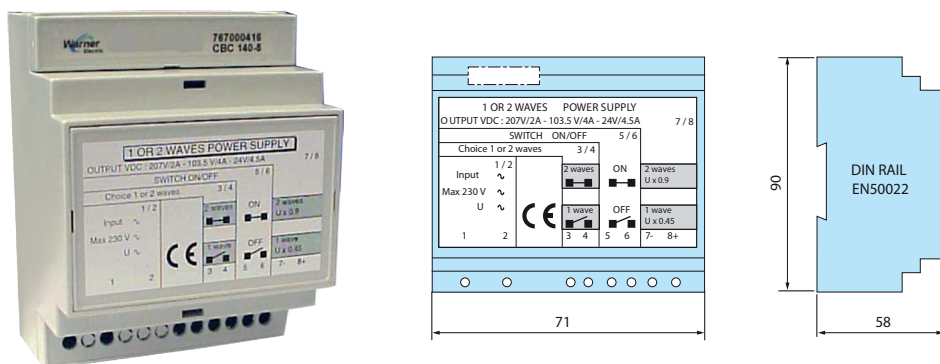

- Plastic guard for the extended pulley shaft (CODE COP0077).
- Hexagonal wrench bracket and brake release screws kit (CODE: GEN0127): metal wall mounting bracket (CODE: GEN0124) or control unit with hex wrench (CODE: GEN0123) and seats for SSB brake release screws.

Figure 5 – Wall bracket kit with hexagonal wrench and housings for the SSB release screws (CODE: GEN0127).

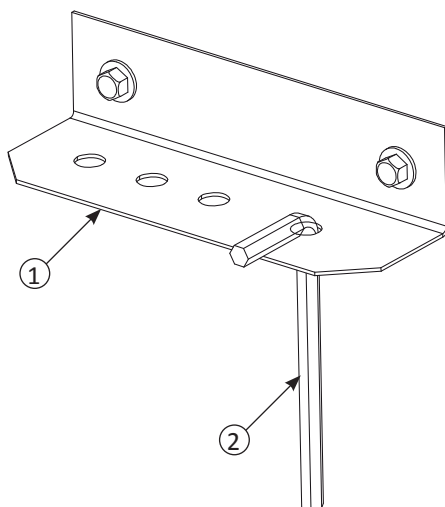

① SSB brake wall bracket code: GEN0124

② SSB brake release hex wrench code: GEN0123

#### 4. OVERALL DIMENSIONS

Figure 6 – Overall dimensions in the case of SH190 winch with SSB option without the drive pulley

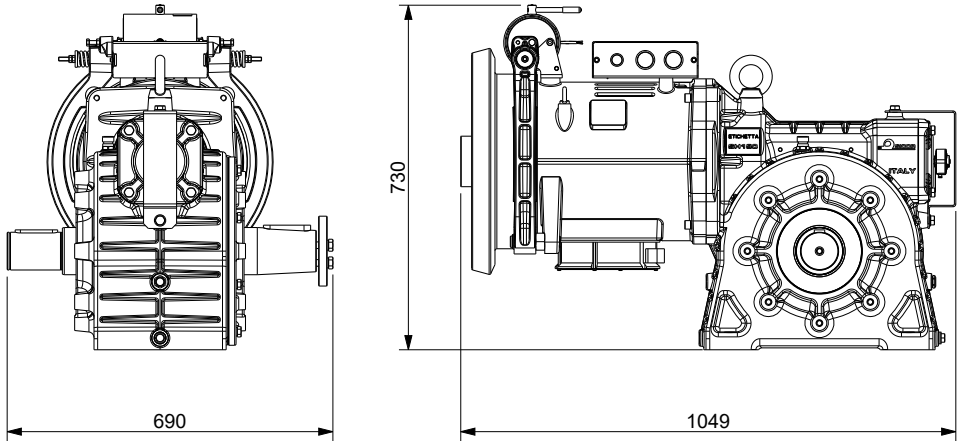
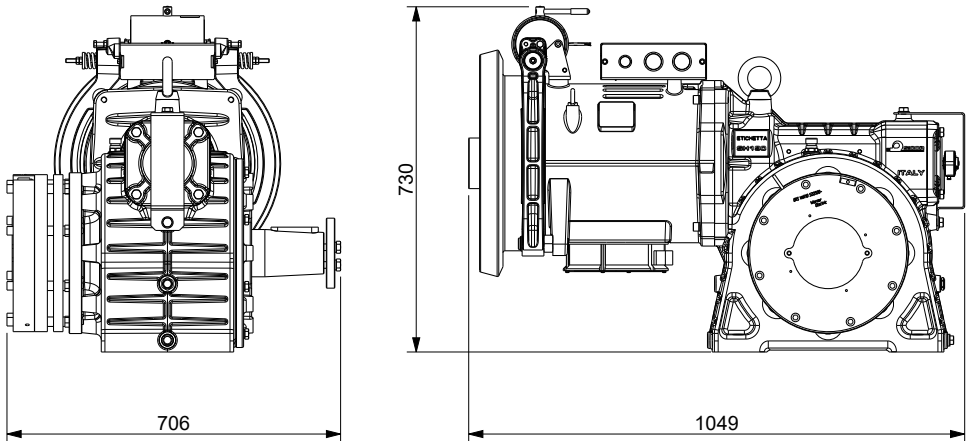

Figure 7 – Overall dimensions in the case of SH190 winch with emergency SSB (complete kit) without the drive pulley



## 5. SSB SUPPLY

The SH190B type of winch includes various types of supply. In particular, the product range is divided in:

- Complete SSB SH190 kit.
- SSB-SH190 winch option.
- Complete Kit for SH190 winch (CODE: XFR0241 duty cycle 60%, XFR0242 duty cycle 100%).
- Accessories.

Details of the various types of supply, listed previously, are given in the following paragraphs.

### 5.1. COMPLETE SSB SH190 KIT

The complete SSB kit on the SH190 winch comprises the supply of the following components:

- SH190 winch with extended pulley shaft.
- Electromagnetic Warner ERS VAR10-SZ2500/3000 brake (CODE: FAL0039 duty cycle 60%, FAL0040 duty cycle 100%)
- Hexagonal wrench bracket kit with housing for SSB brake release screws (CODE: GEN0127).

### 5.2. SSB SH190 WINCH OPTION

The product supply for this configuration comprises:

- SH190 winch with extended pulley shaft.
- Plastic guard for the extended pulley shaft (CODE COP0077).

### 5.3. COMPLETION KIT

The completion kit (only suitable for winches with the SSB option) includes:

- Electromagnetic Warner ERS VAR10-SZ2500/3000 brake (CODE: FAL0039 duty cycle 60%, FAL0040 duty cycle 100%).
- Hexagonal wrench bracket kit with housing for SSB release screws (CODE: GEN0127).
- Brake support flange (CODE: PIS0083).

### 5.4. ACCESSORIES

- Electromagnetic brake power supply (paragraph 3.3): the supply does not include electric connecting cables (CODE: GEN0122).

## 6. INSTALLATION AND MAINTENANCE

Installation and/or maintenance operations may only be performed by competent personnel, authorised to access the machinery and having the necessary equipment and instruments.





Before starting any installation and/or maintenance work, attention must be given to the safety requirements given below in order to avoid accidents and damage to the product components:

- Make sure you have the appropriate personal protection equipment (helmet, body harness, gloves, safety shoes).
- Always secure equipment and other objects to avoid them accidentally falling from a height.
- Make sure that the power has been disconnected before working on electrical equipment.
- Only install the electrical system and/or the connections once you have read the relative instructions.
- Before starting installation, see if there are any structural and space limitations where the installation / maintenance work will be carried out.
- It is advisable to consider where and when you will be working and which assembly/maintenance procedures you will follow.
- Take account beforehand of all significant limitations that may regard the various operation phases and do not start work without first evaluating the consequences.

## 7. SAFETY PRECAUTIONS



Installation personnel are responsible for making sure that installation and maintenance are carried out in accordance with the essential health and safety protection criteria and requirements. Installation and maintenance personnel must observe and remain updated in relation to accident prevention regulations and legal obligations to avoid injury to persons or damage to the product during installation, maintenance and repair.

Important warnings regarding safety and hazards are signalled using the following symbols.

	Warning of high hazard risk (e.g.: zones of shearing, cutting, crushing, etc.).
	Generic hazard warning.
	Risk of damage to parts of the machinery (for example due to incorrect installation or similar).
	Symbol to indicate additional important information.

## 8. TRANSPORTING AND HANDLING LOADS

Assembly/maintenance work may mean loads have to be transported and/or handled.

	Before lifting and/or moving a load by hand, each time check how much it weighs and decide the best way to handle it while bearing in mind any standards or laws in this regard.
	Bear in mind the following when handling loads: <ul style="list-style-type: none"> <li>- When lifting and transporting loads, avoid to move suspended loads over people.</li> <li>- Always visually inspect the lifting means and harness (winches, hooks, ropes. etc.,) before using or starting them.</li> <li>- When harnessing the load, the lifting point must be located near the centre of gravity of the load itself to avoid any rotating effects and/or tipping over.</li> </ul>

## 9. INSTALLING THE COMPLETE SSB KIT

- Place the brake securing flange CODE: PIS0067 at the extended pulley shaft. Position the completely painted part towards the winch so that it remains in the exposed area for contact with the surface of the clutch.



Incorrect positioning of the brake support flange may affect correct operation functioning of the device.

Then secure the component to the winch body using 8 x M12x45 with a tightening torque of 97 Nm.

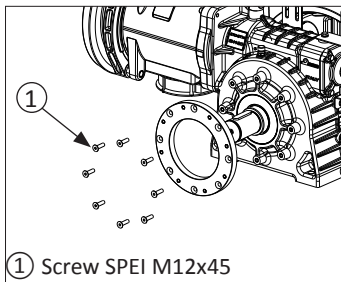

- Use dial gauge to check the perpendicularity of the brake support flange with pulley shaft extension. Perform this check at several points as shown in the figure. The maximum deviation from perpendicularity is  $\pm 0.1$  mm.



Incorrect positioning of the brake support plate causes significant variations when braking. If necessary, loosen the screws and reposition the components correctly. Use calibrated metal shims as required to ensure to the correct positioning of the component.

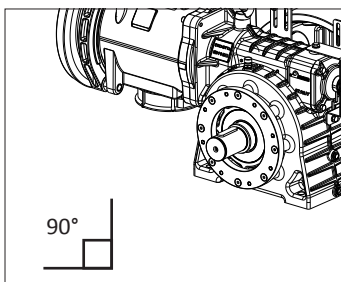

- Insert the tongue in the groove on the shaft. Position the brake hub on the shaft with the knurled part towards the brake supporting flange and lock in position with the 80 diameter circlip supplied.

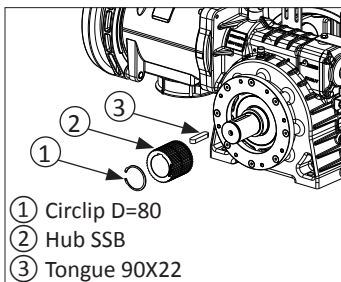

- Fit the clutch disc on the hub with the projection facing outward. Check that the clutch surface is evenly touching the structure surface.



The clutch surface is designed to work in dry conditions. The friction material must not come into contact with any type of oil, grease, or abrasive powder.

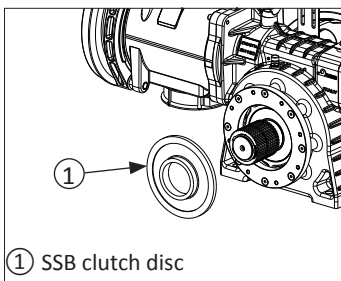



- Align the brake with the fixing flange and secure it in position using the screws supplied (8 M12x150 and 8 M12 safety washers). Tighten the fastening screws with a torque wrench in a star sequence, using a pretightening torque of 50Nm and a final torque of 130Nm



The brake is intended for static applications and/or as a safety brake. Dynamic brakings are limited to emergency and trial brakings.

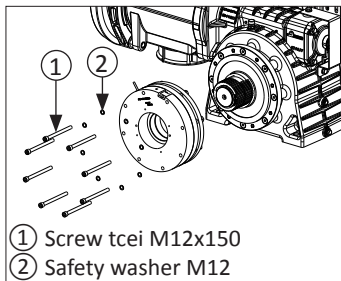

- Mount the brake release screw bracket (CODE: GEN0127) - supplied - inside the control panel or near it. Then remove the two transport screws of the brake, putting them in their housings.

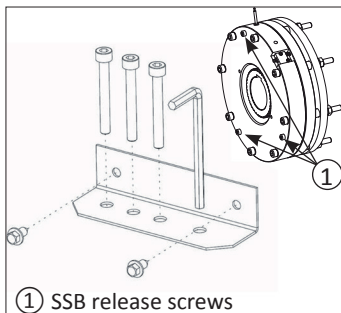



- Electrically connect the device following the indications given in paragraph 11.

## 10. COMPLETION KIT INSTALLATION

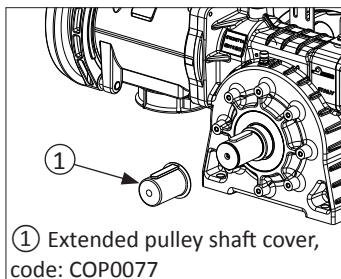
- Check the correct position of the winch.
- Remove the plastic cover of the extended pulley shaft (CODE: COP0077). If necessary, clean the component thoroughly before continuing with installation.
- Follow steps 1 to 5 in paragraph 9 of this manual.



## 11. ELECTRICAL CONNECTIONS

	<p>All electrical connections must be made with the main switch in the OFF position.</p>
	<p>Make sure that the rated supply voltage is maintained at all times.</p>
	<p>Direct current is used to power the brake so as to have a very reduced turn-on time of the brake which is ideal in the case of emergency stops.</p>

These instructions in no way replace the Warner Electric Europe technical documentation enclosed with this manual.

### 11.1. BRAKE

The brake device, type ERS VAR010-sz2500/3000, works with the direct power supply (VDC207/103,5). The brake power supply (CODE: GEN0122) is not included in the standard SSB supply (complete kit) but is an optional accessory available only on request.

Electrically wire the device, connecting the cable leading from the brake to the power on the control panel or to the power supply provided. Reversing polarity will not affect how the brake works.

The connection cables must have an adequate cross section to prevent any sudden rise in voltage between source and brake. The tolerance in the supply of voltage to the brake terminals is +5%/-10%.

The brake must only be powered after the transport screws have been removed - they can be easily identified by their red coloured heads.

## 11.2. MICROSWITCH

If there is a power failure to the brake coil (slow shaft braked) the microswitch contacts change over to the NC position as indicated in Figure 8; on the contrary, in the case of a powered brake coil (slow shaft free), the microswitch is changed over to the NO position. Please see the data in Table 1 for the electrical specifications.

Figure 8 – Microswitch electrical connections: contact change-over in the case of no current to the SSB coil

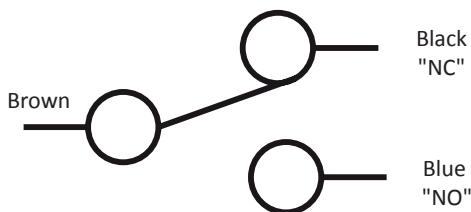

## 11.3. SSB POWER SUPPLY

The brake power supply (CODE: GEN0122) is not included in the standard SSB supply (complete kit) but is an optional accessory available only on request.

Do the wiring, connecting the main power (maximum voltage 230VAC) to terminals 1 and 2 on the terminal block. Now connect the brake coil cables to terminals 7 and 8 and the SSB drive signal to terminals 5 and 6 (Figure 9). Lastly connect a timed relay (0.5-2s / 9A-400V) to terminals 3 and 4 for controlling over-excitation. The switch for the SSB drive (9A - 400V) and the relay are not included in the supply.

Figure 9 – Wiring diagram for the SSB power supply: KA switch (9A, 400V) and the relay are not included in the supply

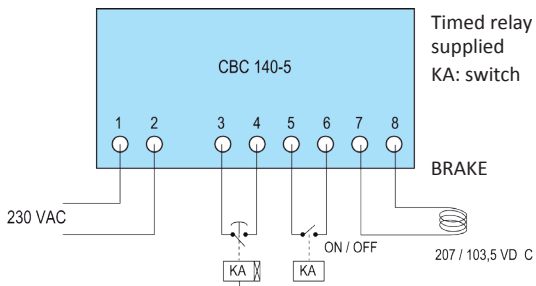

## 12. STARTING THE WINCH

This paragraph is only valid in the case of the complete kit or completion kit. Before starting the device, make sure all the installation instructions given in this manual have been complied with and then proceed as explained below:

- Check that the brake clutch surface is evenly touching the fixing flange.
- Check that the fastening screws of the SSB brake are tightened correctly.
- Check that the fastening screws of the flange are tightened correctly.
- Check that the electrical connections are made correctly.
- Make sure the brake transport screws have been removed and are in the housings in the bracket supplied.
- When the system is stopped check that the SSB brake (Figure 10) air gap is adjusted in compliance with the indications given in paragraph 13.1 of this manual. This check must be done measuring the gap with calibrated metal feeler gauges in several points around the brake's circumference.
- Move the lift a few times and check that when the winch is moving the clutch disc is not rubbing against the braking plates.
- Check the microswitch is working properly as the brake opens and closes. Adjust the microswitch if necessary, following the indications in paragraph 13.2 of this manual.

Figure 10 – Check the brake air gap with calibrated metal feeler gauges in several points around the SSB device

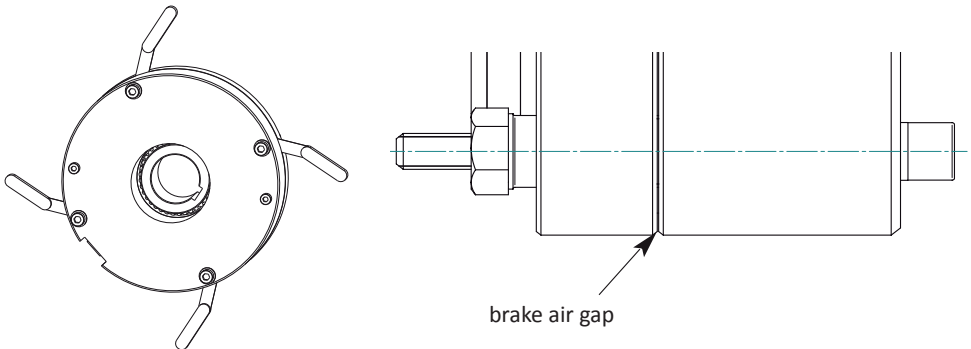

## 13. CHECKS AND MAINTENANCE WORK

The purpose for the checks and maintenance work is to ensure the efficiency and maintain the SSB device in proper working order. Maintenance frequency can vary as it depends on the frequency of use, age, working conditions, location, type of building and on the environmental conditions where it is installed.

To this end, the company providing the assistance and maintenance service must prepare a suitable maintenance schedule for the subject case with maintenance times as short as reasonably possible without in any way compromising the safety of people.

The standard checks and verifications for the single components of the SSB parking brake are given below.

	<p>All checks and maintenance work must be carried out paying particular attention to the safety of the maintenance engineer and of other people.</p>
--	---

- If the guard is mounted on the SSB brake, remove it.
- Check the correct tightness of all the device's fastening screws.
- Check the state of wear of the brake lining, replacing it if necessary.
- Check that the front surface of the fixing flange is perpendicular to the pulley shaft axis.
- Check that the clutch surface is evenly touching the fixing flange. Adjust the position of the brake support flange if necessary.

	<p>An uneven contact of the clutch surface will compromise the braking action of the device and make it wear more quickly.</p>
--	--

- Check the air gap, measuring with calibrated feeler gauges in several points of the device, adjusting the gap if necessary as explained in paragraph 13.1.
- Check that the microswitch is working properly, adjusting it if necessary as explained in paragraph 13.2.
- Check that the electrical connections are made correctly.
- Clean the device thoroughly.
- If the SSB brake has a cover, put it back in place.

### 13.1. SSB BRAKE AIR-GAP ADJUSTMENT

The SSB brake is typically provided with air-gap already regulated. The correct value must be 0,45mm +0,1/-0,05. Check it, using calibrated metal feeler gauges as indicated in figure 10. If this value is greater than the maximum indicated, the clutch disc must be replaced.

	<p>Before starting to check the SSB, make sure the winch is NOT working and that the main brake is working properly.</p>
--	--

	<p>These instructions in no way replace the Warner Electric Europe technical documentation enclosed with this manual.</p>
--	---

## 13.2. SSB BRAKE MICROSWITCH ADJUSTMENT

The SSB brake is typically supplied with the microswitch already adjusted. If necessary, adjust it as explained below:

Figure 11 – Microswitch and adjustment screw

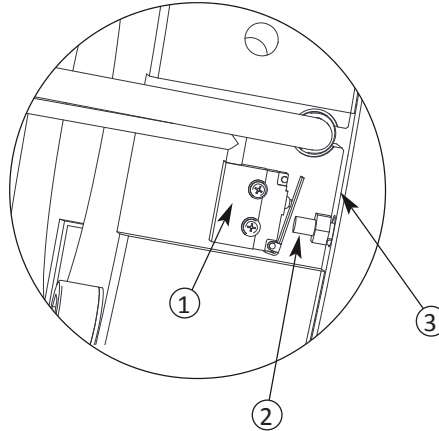

- ① Microswitch
- ② Microswitch adjustment screw
- ③ Air-gap



An uneven contact of the clutch surface will compromise the braking action of the device and make it wear more quickly.

- Put a calibrated 0.15 mm feeler gauge by the microswitch adjustment screw and the movable brake plate.
- Power the brake and turn the adjustment screw until the point of contact is reached with the microswitch (Figure 11).
- Remove the thickness gauge.
- Check correct operation by engaging/disengaging a few times.
- Repeat the operation if necessary.



These instructions in no way replace the Warner Electric Europe technical documentation enclosed with this manual.

## 14. MANUAL EMERGENCY OPERATING

These instructions describe the emergency manual manoeuvre in the case of an SH190 winch equipped with an SSB parking brake (Slow Shaft Brake), type Warner ERS VAR10-SZ2500/3000.

### 14.1. WARNINGS

	<p>MANUAL EMERGENCY MANOEUVRE IS A DANGEROUS TASK. IT CAN BE USED TO MOVE THE CAB EXCLUDING ALL THE PLANT SAFETY CONTACTS. FOR THIS REASON, ANYONE WHO PERFORMS THIS OPERATION MUST HAVE BEEN CAREFULLY TRAINED BY SPECIALISED PERSONNEL AND MUST BE AWARE OF THE RISKS INVOLVED.</p>
--	---

Assistance in the event of an emergency must only be provided by expert, specially trained personnel. All the operations performed in the event of an emergency must strictly follow the instructions in this manual. A copy of this document must therefore be kept near the device and be easy to access if necessary.

In the event of an emergency entailing manual manoeuvres strictly observe the following instructions:

- Follow local safety requirements.
- Do not neglect the safety of passengers at risk in any way.
- Do not put them at risk in any way.
- Make sure that their actions do not create hazardous situations for third parties.
- Communication with any passengers in the cab must be established as soon as possible in order to reassure the people present. This can help to establish the position of the cab in the well more precisely.
- Before each intervention, first inform the passengers of what you intend to do.
- After completion of work, make sure there are no problems with normal operating of the plant.

### 14.2. INSTRUCTIONS FOR AN EMERGENCY MANUAL MANOEUVRE

	<p>AN EMERGENCY MANUAL MANOEUVRE IS DANGEROUS.</p>
--	--

It can be used to move the cab excluding all the plant safety contacts.

For this reason, anyone who performs this operation must have been carefully trained by specialised personnel and must be aware of the risks involved.

	<p>For correct emergency manual operating, carefully follow these instructions.</p>
--	---

- Check that all lift doors of the floors are closed and they cannot be opened in any way.
- **MAKE SURE THE CAB IS AT A FLOOR LEVEL.**
- Place the main switch on the control panel to the OFF position.
- Reassure the passengers in the cab, explaining to them exactly what you intend to do.

Figure 12 – Top view of the main winch brake lever: locking/releasing positions of the main brake lever.

Positions of the top main brake lever

- ① brake active (closed)
- ② brake inactive (open)

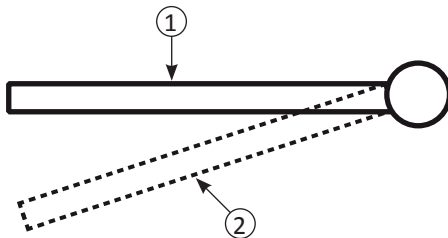



	<p>The passengers must not try to force the cab doors open or attempt to get out of it in any way.</p>
--	--

- Check that the operating conditions of the main brake and winch are safe for moving the cab.

	<p>To see if the main brake on the winch is working properly, check:</p> <ul style="list-style-type: none"> <li>- if the brake shoes are broken</li> <li>- if the brake linings are damaged which limits the contact surface</li> <li>- if contact with the braking surface is uniform</li> </ul>
--	---

- Release the main brake positioned at the top of the winch using the manual release lever (Figure 12 – ②).
- With the main brake released, try turning the winch's flywheel in both directions, making certain it is blocked.

	<p>If the fast shaft of the winch is turning freely or you notice excessive play, it means the winch is "out of order" and the cab is being supported only by the SSB emergency brake.</p>
--	--

	<p>If the winch and/or the main brake are out of use or the safety is inserted, perform the rescue procedure and ensure that the cab is secure by using a special device suitable for the type of plant, place and operating conditions.</p>
--	--

- Release manual lever to unlock the main winch brake (Figure 12 – ①).
- Retrieve the ssb brake release screws and the hexagonal wrench from the housings in the wall bracket.



- If the front guard is mounted on the SSB brake, remove it.
- Release the ssb emergency brake, tightening the release screws in their place on the brake body (figure 13).

Figure 13 – SSB emergency brake release screws (opening)

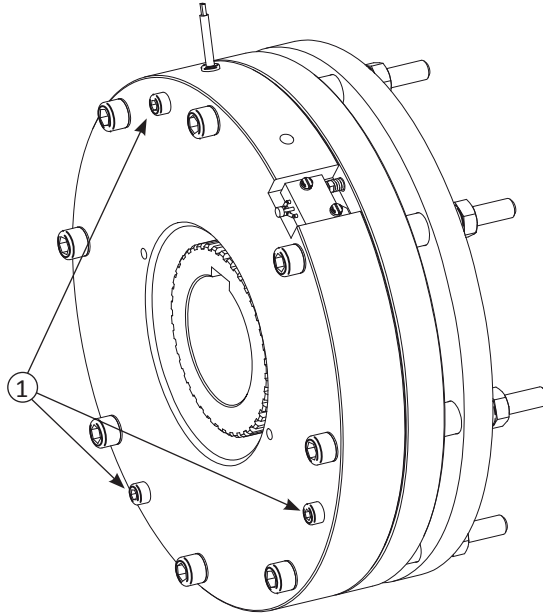

① SSB release screws

- Check rotation direction of the winch for the cab movement manoeuvre.
- Manually block rotation of the winch's flywheel.
- Release the main brake by turning the manual lever (Figure 12 – ②).
- Start the manual manoeuvre, bringing the cab to the destination floor.
- Release manual lever to unlock the main winch brake (Figure 12 – ①).
- Open the cabin doors and help the passengers.
- Close the cab doors.
- Restore the ssb emergency brake removing the release screws.
- Put the ssb release screws and the hexagonal wrench back into the housings in the wall bracket supplied.
- Put the front protection of the ssb back in place.

15. ANNEXES

15.1. TÜV CERTIFICATION FOR SH190 SSB WINCH

ZERTIFIKAT ◆ CERTIFICATE ◆ 認証証書 ◆ CERTIFICADO ◆ CERTIFICAT



Industrie Service

## EU TYPE-EXAMINATION CERTIFICATE

According to Annex IV, Part A of 2014/33/EU Directive

<b>Certificate No.:</b>	EU-BD 592
<b>Certification Body of the Notified Body:</b>	TÜV SÜD Industrie Service GmbH Westendstr. 199 80686 Munich - Germany Identification No. 0036
<b>Certificate Holder:</b>	WARNER Electric Europe 7, rue de Champfleür BP 20095 49124 Saint Barthélemy d'Anjou - France
<b>Manufacturer of the Test Sample:</b> <small>(Manufacturer of Serial Production – see Enclosure)</small>	WARNER Electric Europe 7, rue de Champfleür BP 20095 49124 Saint Barthélemy d'Anjou - France
<b>Product:</b>	Braking device acting on the shaft of the traction sheave, as part of the protection device against overspeed for the car moving in upwards direction and braking element against unintended car movement
<b>Type:</b>	Type: ERS VAR10 Size: SZ1010/____ SZ2500/____ SZ5000/____
<b>Directive:</b>	2014/33/EU
<b>Reference Standards:</b>	EN 81-20:2014 EN 81-50:2014 EN 81-1:1998+A3:2009
<b>Test Report:</b>	EU-BD 592 of 2016-02-29
<b>Outcome:</b>	The safety component conforms to the essential health and safety requirements of the mentioned Directive as long as the requirements of the annex of this certificate are kept.
<b>Date of Issue:</b>	2016-02-29
<b>Date of Validity:</b>	from 2016-04-20

*Werner Rau*  
Werner Rau

Certification Body "lifts and cranes"





## SICOR S.R.L.

Head Office and Production Centre

Viale Caproni 32 (Industrial Area) 38068 Rovereto (TN) Italy

Ph.. +39 0464 484111 Fax +39 0464 484100

[www.sicoritaly.com](http://www.sicoritaly.com) [info@sicoritaly.com](mailto:info@sicoritaly.com)