

# OPERATION AND MAINTENANCE MANUAL

## SG75

COD.: MUM0327 REV. 01

english

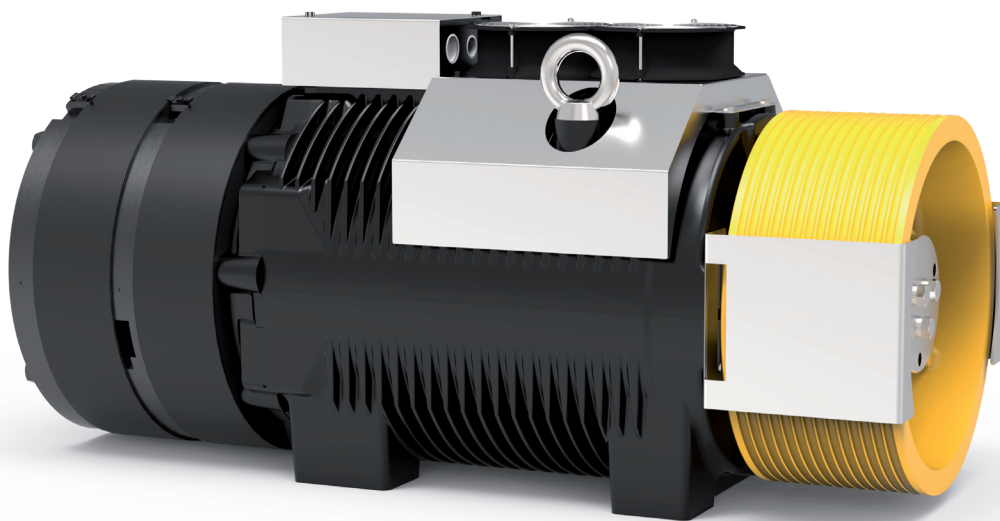

SICOR S.R.L.

Head Office and Production Centre

Viale Caproni 32 (Industrial Area) 38068 Rovereto (TN) Italy

Ph.. +39 0464 484111 Fax +39 0464 484100

[www.sicoritaly.com](http://www.sicoritaly.com) [info@sicoritaly.com](mailto:info@sicoritaly.com)

 **SICOR**  
DRIVING THE FUTURE



## INDICE

1.	LETTER TO THE CUSTOMER .....	2
2.	DESCRIPTION OF THE GEARLESS MACHINE.....	2
2.1.	DIMENSIONS/TECHNICAL SPECIFICATIONS SG75 .....	3
2.2.	DIMENSIONS/TECHNICAL SPECIFICATIONS SG75F .....	4
3.	MACHINE IDENTIFICATION .....	5
4.	WARRANTY .....	6
5.	GENERAL DELIVERY NOTES.....	7
6.	SAFETY PRECAUTIONS.....	8
7.	SAFETY REQUIREMENTS .....	9
8.	MOVING THE WINCH .....	11
9.	NOTES FOR INSTALLATION .....	13
9.1.	MECHANICAL INSTALLATION .....	13
9.1.1.	CABLE INSTALLATION.....	14
9.1.2.	SECURING THE GEARLESS MACHINE .....	14
9.1.3.	CABLE GUARD.....	15
9.2.	ELECTRICAL INSTALLATION.....	16
9.2.1.	ELECTRIC MOTOR .....	16
9.2.2.	TERMINAL BOARD WIRING DIAGRAM .....	17
9.3.	ENCODER .....	18
9.3.1.	ABSOLUTE ROTARY ENCODER CONFIGURATION - ENDAT INTERFACE.....	19
9.3.2.	ROTARY ENCODER SIN/COS INTERFACE CONFIGURATION.....	21
9.3.3.	INSTRUCTIONS FOR INSTALLING THE EXTENSION CABLE ON THE HEIDENHAIN ENDAT ECN 1313 ENCODER.....	22
9.4.	ELECTROMAGNETIC BRAKE .....	24
9.4.1.	EMC DIRECTIVE.....	26
9.4.2.	MANUAL RELEASE LEVER .....	26
9.5.	POWER SUPPLY UNIT .....	27
9.5.1.	POWER SUPPLY UNIT ELECTRICAL CONNECTION DRAWINGS .....	28
10.	STARTING THE GEARLESS MACHINE FOR THE FIRST TIME.....	30
11.	MAINTENANCE .....	31
11.1.	ENCODER REPLACEMENT .....	32
11.2.	VENTILATION KIT .....	33
11.3.	PULLEY DISMANTLING .....	34
11.4.	PULLEY ASSEMBLY .....	35
12.	EMERGENCY OPERATION.....	35
13.	DISPOSAL/RECYCLING .....	36

## 1. LETTER TO THE CUSTOMER

Dear Customer,

SICOR gearless machines are designed and manufactured in accordance with the Machinery Directive 2006/42/CE, 2014/33/UE, EN 81-20, EN 81-50, UNI EN 12100 and in full respect of the regulations in force.

They do not therefore represent a hazard for installation and maintenance personnel if used according to the instructions supplied in this manual and if the relative safety devices are always kept in a good working state.

This document attests that the safety devices on the machine were in working order when the machine was delivered; that this manual has been delivered with the machine and that the installation personnel is responsible for fully complying with its contents.

SICOR declines any and all responsibility for damage caused by alterations to, tampering with and any operations performed on the equipment which do not comply with the contents of the manual, with its instructions or with information provided in other documents.

SICOR congratulates you on choosing this product and hopes that you will be impressed by its excellent performance.

SICOR S.R.L.

## 2. DESCRIPTION OF THE GEARLESS MACHINE

SG75 are permanent magnet synchronous machines developed and designed as gearless machines for the handling of cable elevator systems.

- NO OTHER APPLICATION IS CONSIDERED VALID.
- OTHER APPLICATIONS WILL BE CONSIDERED VALID ONLY AFTER CONSULTATION WITH SICOR.

The SG75 may be used for systems with suspension 1:1 or higher.

The brakes of the machine are certified for use as a safety system for the upward over-speed of the cabin.

The SG75 motors require an inverter and an encoder for their operation (the encoder is supplied installed on the machine).

## 2.1. DIMENSIONS/TECHNICAL SPECIFICATIONS SG75

The tables provide standard data, other data and configurations are possible.

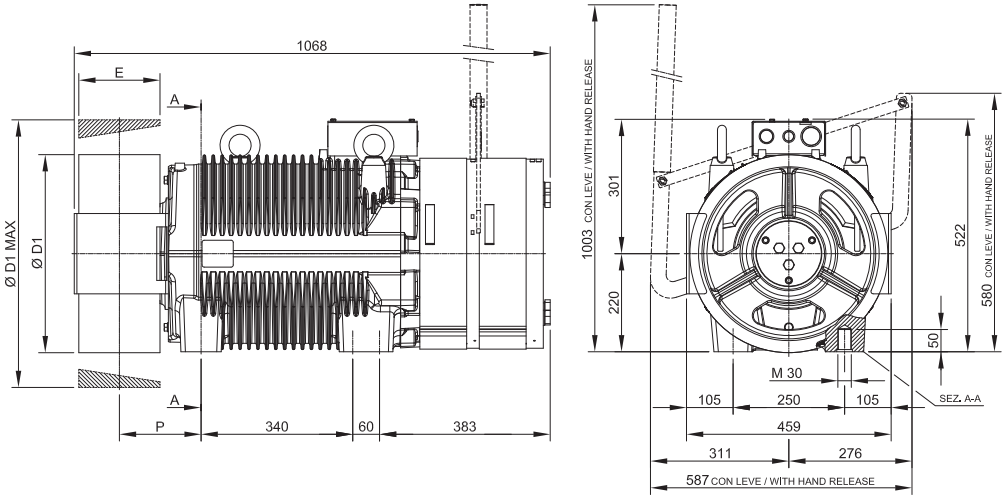

Ø D1 [mm]	E [mm]	P [mm]	Max Weight [kg]	Inertia [kgm <sup>2</sup> ]	Roping System	Torque S3 40% [Nm]	Max Static Load [kN - kg]	Max Power** [kW]
320	182	184	875	2,37	CSW*	1960	78,5 - 8000	49,2
360				2,79				
400				3,35				
440				4,02				
480				4,41				
520	150	167	875	4,99	CSW*	1960	78,5 - 8000	49,2
600				7,57				

Brake Specifications		
Braking Torque	2x2800	[Nm]
Standard Supply Voltage	207	[V DC]
Overexcitation	--	[V DC]
Power	2x190	[W]
Overexcitation	--	[W]
Degree of Protection	IP10	

Standard Encoder Data		
Type	Absolute - EnDat	
Model	Heidenhain ECN 1313	
Positions values/rev	2048 imp/giro 13 bits	
Degree of Protection	IP40	
Standard Cable Length	10	[m]

\*) CSW : Conventional single wrap.

\*\*\*) Sample data; for more detailed evaluations we recommend our product configurator.

## 2.2. DIMENSIONS/TECHNICAL SPECIFICATIONS SG75F

The tables provide standard data, other data and configurations are possible.

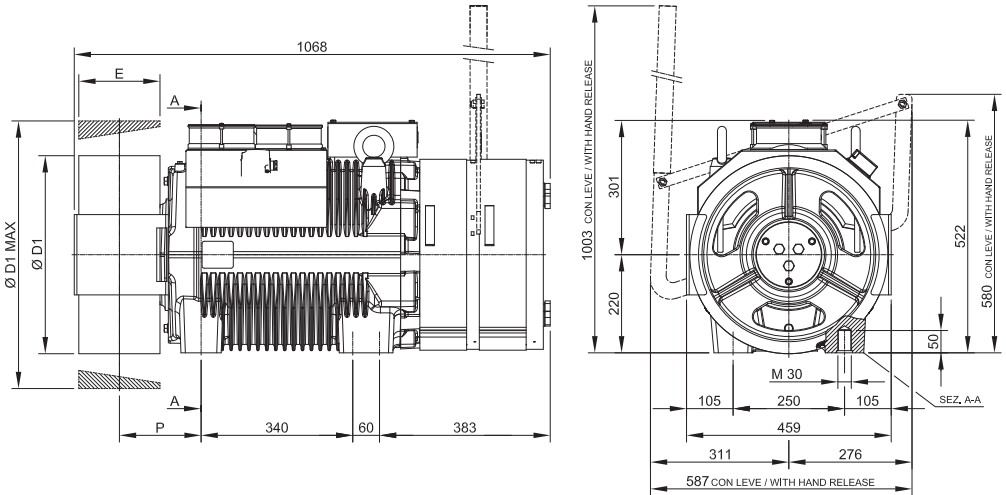

Ø D1 [mm]	E [mm]	P [mm]	Max Weight [kg]	Inertia [kgm <sup>2</sup> ]	Roping System	Torque S3 40% [Nm]	Max Static Load [kN - kg]	Max Power** [kW]
320	182	184	888	2,37	CSW*	2350	78,5 - 8000	59,1
360				2,79				
400				3,35				
440				4,02				
480				4,41				
520	150	167		4,99				
600				7,57				

Brake Specifications		
Braking Torque	2x2800	[Nm]
Standard Supply Voltage	207	[V DC]
Overexcitation	--	[V DC]
Power	2x190	[W]
Overexcitation	--	[W]
Degree of Protection	IP10	

Standard Encoder Data		
Type	Absolute - EnDat	
Model	Heidenhain ECN 1313	
Positions values/rev	2048 imp/giro 13 bits	
Degree of Protection	IP40	
Standard Cable Length	10	[m]

Ventilation Data		
Voltage	220	[V]
Power	2x38	[W]

\*) CSW : Conventional single wrap.

\*\*) Sample data; for more detailed evaluations we recommend our product configurator.

### 3. MACHINE IDENTIFICATION

In any communication with SICOR or its technical assistance centres concerning a gearless machine, always mention the serial number indicated on the machine's ID plate.

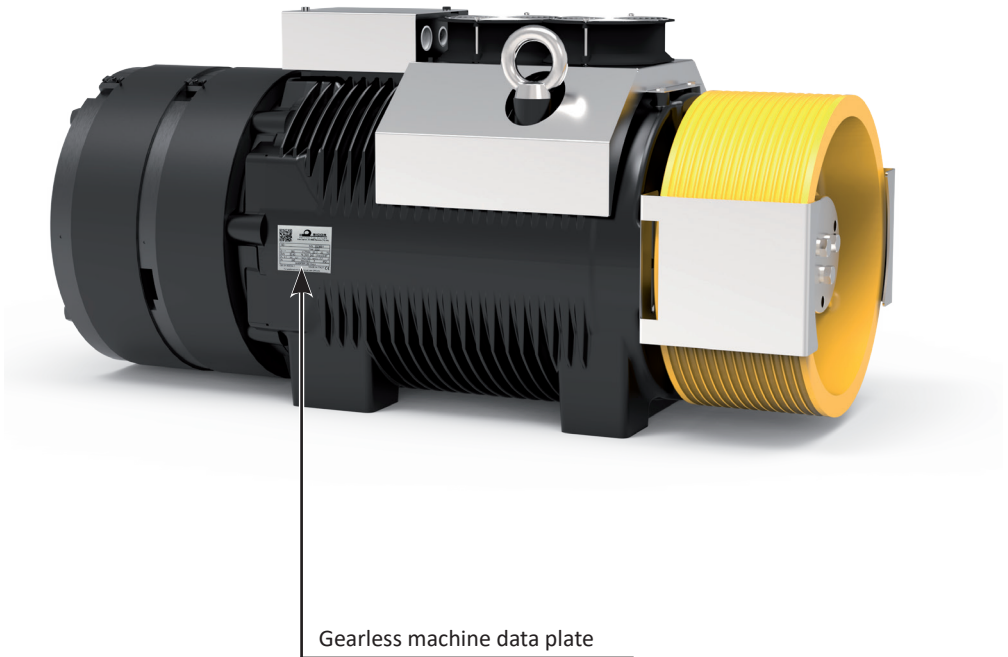

## 4. WARRANTY

- The warranty, apart from other contractual agreements, is regulated by the following clauses:
  - The warranty on SICOR products is valid for a period of TWO years from the date of the shipping document. During this period, SICOR will replace free of charge any component recognised as faulty.
  - A component can be declared faulty only if the fault is recognised by SICOR.
  - Parts under warranty, to be repaired or replaced, must be sent to SICOR carriage paid.
  - The Customer must send any request for technical assistance to SICOR in writing. Labour, travel and board and lodging costs must be met by the Customer.
- The warranty lapses automatically when one of the following conditions applies:
  - The parts for which service has been requested have been tampered with.
  - The type of application was unauthorised or not agreed beforehand in writing with SICOR.
  - The use of the machine does not conform to the characteristics for which it was built or to the indications in the technical catalogue or in this "Use and Maintenance Manual".
  - The identification plates are missing and the machine cannot be identified.
- The warranty does not cover operational parts subject to normal wear and tear: brake linings, bearings, electric windings.
- The warranty does not include indemnity for transport costs or machine stoppage.
- Procedures for action under warranty:
  - All warranty claims must be communicated to SICOR within 8 days of the anomaly appearing, in writing or by fax.
  - SICOR will confirm in writing or by fax any acceptance of repair work to be performed by the Customer under warranty or will send its own technicians.
  - Any faulty material replaced by the Customer must remain at SICOR's disposition for 30 days so that any necessary checks can be made or the parts shipped to SICOR if specifically requested in writing by the company.
  - Absolutely no claims will be accepted for warranty repairs that were not previously authorised in writing by SICOR.
  - In all cases, full photographic documentation of repair work must be presented; this is not only for documentary reasons but also to allow SICOR to correct or further improve the quality and reliability of its machines.



**5. GENERAL DELIVERY NOTES**

Gearless machines can be shipped on pallets or in crates.  
 In all cases, on receipt of the gearless machine, check that:

- the packing is undamaged
- the supply corresponds to the specifications of the order (see waybill or packing list)
- there is no visible damage to the gearless machine or its accessories

In the event of damage or missing pieces, immediately send a detailed report to SICOR, its agent, or the shipping agent.

Spare parts or parts of equipment of the supply, when necessary, are packed in separate containers.

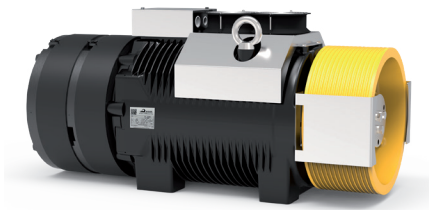

Gearless complete with accessories according to order specifications

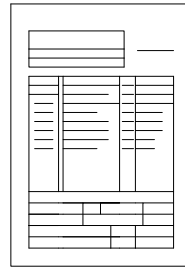

Machine data sheet Work Order



Operation manual

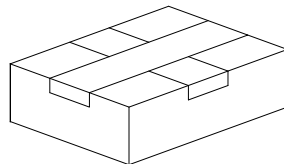





Box with spare parts (if requested)

## 6. SAFETY PRECAUTIONS

Installation personnel are responsible for making sure that installation and maintenance are carried out in accordance with the essential criteria and requisites for health and safety protection. Installation and maintenance personnel must observe and remain updated in relation to accident prevention regulations and legal obligations to avoid injury to persons or damage to the product during installation, maintenance and repair.

Important warnings regarding safety and hazards are signalled using the following symbols.

	Warning of high hazard risk (e.g.: zones of shearing, cutting, crushing, etc.).
	Generic hazard warning.
	Risk of damage to parts of the machinery (for example due to incorrect installation or similar).
	Symbol to indicate additional important information.

WHEN THESE WARNINGS APPEAR,  
PROCEED WITH THE UTMOST CAUTION.

Definitions: INSTALLATION and/or MAINTENANCE PERSONNEL:

qualified operator recognised as such by the Customer, authorised by the Customer to work on the machine for installation and maintenance operations.

## 7. SAFETY REQUIREMENTS



Installers or maintenance personnel must be aware of the dangers associated with the machine and must have read and understood the safety precautions in this manual.

Before installing the gearless machine the customer must verify that the concrete slab and/or the support structures of the shifting loads and the gearless machine itself, providing the required safety factors. The Customer **MUST** also respect the distances from walls and from other machines in accordance with the directives and standards in force in the country where the gearless machine will be installed.



### LIFTING

To move the gearless machine (see also "Transportation" chapter 8) use the eyelet of the winch in suspension or non-metal straps or a forklift truck of suitable capacity to raise the winch up to 30 cm from the floor and handled slowly.

Do not lift loads additional to the weight of the gearless machine itself with the supplied eyebolt. Check that the eyebolt is fully tightened with a closing torque such as to prevent loosening during handling and/or installation.



### EXCLUSION OF POWER SOURCES

Before performing any cleaning and/or maintenance operations, the maintenance engineer must disconnect the gearless machine, exclude the power supply and must wait until the heated areas of the motor reach room temperature.



### WARNING

Do not lean and/or sit on the gearless machine, either when it is in or out of service.



Do not deposit or place any objects or containers of liquids etc. on the gearless machine and especially on electrical parts.



Never tamper with or disable the safety devices or by-pass them or use them for purposes other than those for which they were intended. Do not tamper with or damage or remove the number plates. If deteriorated or illegible, immediately ask SICOR for replacement.



When working near the gearless machine, installers and maintenance personnel **MUST NEVER WEAR LOOSE AND/OR TORN CLOTHING** (scarves, cravats, hats, necklaces, belts, watches, bracelets, rings, etc...).



Use the gearless machine according to specifications and technical data on the gearless machine ID plate.



When the power to the motor is OFF, it is not able to develop any torque. In this situation, if the brake is opened the cabin can accelerate in an uncontrolled manner.

For this reason, we recommend that the winding of the motor is kept in short-circuit when the power is OFF. The motor will thereby develop a braking torque proportional to the rotation speed and the current that circulates in the windings will be comparable with the rated one.

In this way we obtain a braking effect comparable to that of a traditional gear (thus the masses are prevented from accelerating uncontrollably).

The short-circuit must be done through the main contacts of the contactors (since the current is approximately the rated value of the motor).

**NEVER CONNECT THE WINDINGS IN SHORT-CIRCUIT IF THE CURRENT IS NOT OFF.**



Check the correct connection of the temperature sensors located inside the windings.



The components and elements to ensure safety (brake, safety devices, etc...) should NEVER be removed and/or bypassed.



Under use conditions, the surface of the gearless machine can reach very high temperatures. Danger of burning.



High magnetic fields may be present close to the machine. KEEP ELECTROMEDICAL AND ELECTRONIC EQUIPMENT AT A SAFE DISTANCE (SUCH AS PACEMAKERS) TO AVOID MALFUNCTIONS.

## 8. MOVING THE WINCH

WARNING  
RISK OF CRUSHING,  
IMPACT AND ABRASION



The personnel handling the gearless machine must have read the safety requirements in paragraph 7 of this manual and must wear personal protective equipment.

The gearless machine is delivered by SICOR in crates or on pallets wrapped in a protective plastic bag.



WARNING

Never move the crates by dragging them. Always lift them. Do not remove the machine from its packing before having brought it as near as possible to the final position.

A winch with cables or a fork lift of adequate capacity is needed to move the crate.



The forks must also be positioned as widely apart as possible to avoid tipping over.



If the machine has been shipped on a pallet, use an adequately sized load spreader when moving with a crane so that the lifting cables or chains are kept in a vertical position and do not damage parts of the machine.



WARNING

- During handling, remember the following points:
  - proceed slowly
  - do not lift the crate more than 30 cm off the ground unless obstacles are present.
  - lay the crate on the ground slowly
- When unpacking the crate, start from the top and use suitable tools to open it. Afterwards, if the packaging is a crate, remove the side walls, removing the nails below from the pallet. When the machine is unpacked, **DO NOT DISPOSE OF THE PACKAGING IN THE ENVIRONMENT**, but rather reuse it or send it to a recycling company.
- Once the walls of the crate have been removed, check that the supply corresponds with the shipping document and the order.  
If there is a discrepancy with the order, immediately notify SICOR or their agent. When necessary, proceed as described in paragraph 5 "General delivery notes".

When handling the unpacked gearless machine, use a crane or a forklift with wide forks of appropriate capacity, using the eyebolt of the reduction gear and a non-metal band around the motor.

**CAUTION**

Make sure there are no people exposed within the operating range of transport means with the gearless machine (danger zone).



If the gearless machine is stored for long periods, leave it on its pallet and make sure it is adequately protected (at least with a waterproof covering) to prevent oxidation of the internal or external parts of the machine.

Remember that the oxidation of shafts or other mechanical parts reduces its fatigue strength.

Excessively long storage times are not advisable (max. storage time = one year).

Storage temperature + 20°C / + 60°C.

Always check the free rotation of the gearless machine shaft before installation (RELEASE THE BRAKE FOR THIS PURPOSE). If necessary, consult the related manual supplied with this machine.

During this operation, pay attention to the presence of abnormal noise coming from the gearless machine.

## 9. NOTES FOR INSTALLATION

### 9.1. MECHANICAL INSTALLATION



#### WARNING

The location in which the gearless machine is installed must have the following characteristics:

- It must be dry and not dusty: this is essential to prevent electrochemical corrosion of mechanical parts (clean the machine room before installing the machine/clean electrical parts from any condensation).
- The room must be ventilated: the room must have adequate openings or conditions to allow sufficient renewal of air to dissipate the heat transferred from the machine.
- The room temperature must be between 5° C and 40° C.  
Maximum humidity 95% non-condensing 0÷1000m A.S.L.  
For other values, consult SICOR.

The customer must verify that the electrical network where the gearless machine will be installed has suitably gauged cables, is correctly grounded and adequate installed power.

The installation of the machine, the electrical connections and adjustments to optimise the system must be performed by qualified and experienced personnel.



During the assembly and/or handling the moving and/or delicate parts (brake, encoder) must be protected against accidental knocks and dust.



No welding should be performed on the gearless machine (neither during installation nor at other stages). Welding can damage moving parts, bearings and magnets.



Allow a minimum of 80 mm between the encoder and the wall so that it is always accessible for maintenance and/or replacement

## 9.1.1. CABLE INSTALLATION



The gearless machine must always be placed at the top of the support beam. NO OTHER POSITION IS CONSIDERED VALID. The support surface should provide appropriate stiffness and strength to support loads applied to the machine.

If there are more pulley grooves than cables, position them as described in the diagram below.

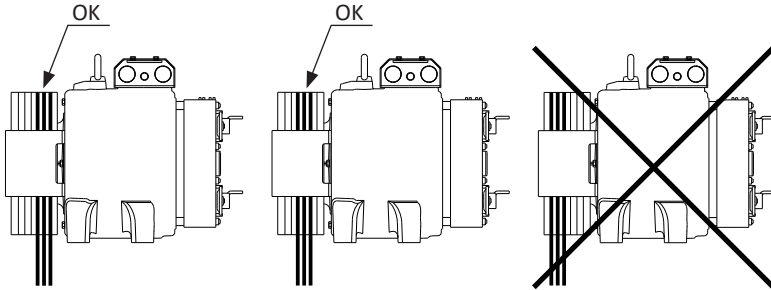

The gearless machine allows types of systems with vertical and horizontal cable configurations.

In case of lateral (horizontal) release of the cable, the drive will be supported laterally on the shaft through appropriate measures. The drive fastening screws must not be subject to cutting stress in any way.

## 9.1.2. SECURING THE GEARLESS MACHINE



The gearless machine **MUST** be fixed to the supporting surface by means of 6 screws with minimum strength class 8.8 (positioned at the feet). Tightening torque for screws:

	SG75
Screws	M30 (8.8)
Tightening torque [Nm]	1420



Tighten the screw threads to a minimum length of 1.5 times the diameter. Maximum thread depth is 50mm.



The maximum allowable flatness tolerances at the feet of support is 0.3 mm.



### 9.1.3. CABLE GUARD

In compliance with EN 81-20 and EN 81-50 standards, devices to prevent cables slipping out of the pulley grooves must include a retainer device located in the vicinity of points where cables enter and exit the pulleys and at least one intermediate retainer device if there is a winding angle of more than 60° underneath the horizontal axis of the pulley and the total winding angle is more than 120°.

Examples of cable retainer device layouts:

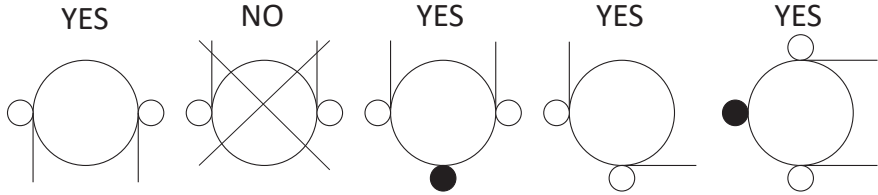

● This device is available as an optional on request.  
Contact SICOR personnel for further details.



To install cable guards on a gearless machine, use only first supply screws or screws with the same specifications M10x16 to avoid damage to internal parts. Place the cable guards at a distance of 2÷3 millimetres from the cables and fasten the screws using a 50 Nm torque.

## 9.2. ELECTRICAL INSTALLATION



**All electrical connections must be made with the main switch in the OFF position**



Use shielded cables (max length 25m); the cable shielding must be appropriately connected.

### 9.2.1. ELECTRIC MOTOR

With the help of the layout (attached to this manual), connect it electrically to the inverter making sure the U, V, W and grounding phases are connected correctly.

**DO NOT CONNECT THE MACHINE DIRECTLY TO THE POWER GRID. THE POWER MUST BE SUPPLIED BY A SUITABLE ELECTRONIC CONVERTER.**



#### IMPORTANT NOTE

The motor is made using permanent magnets with a maximum working temperature of 150°C. Above this limit, the magnets may lose their magnetic characteristics, thus altering the performance of the machine.

Refer to the following table for the technical features of the PTC sensors:

Thermistors
T < 150 °C 750 Ohm
T ≥ 150 °C 4 kOhm

The motor is protected by PTC thermistors.

The thermistors **MUST ONLY BE CONNECTED TO A SPECIFIC CONTROLLER.**

Incorrect connection of the thermistors will burn them out immediately.

The maximum permissible supply voltage is 2.5 V DC.

When connected close the terminal box.



When the terminal box is open, avoid the possibility that any solid or liquid objects may fall and come into contact with the internal parts of the machine.

9.2.2. TERMINAL BOARD WIRING DIAGRAM

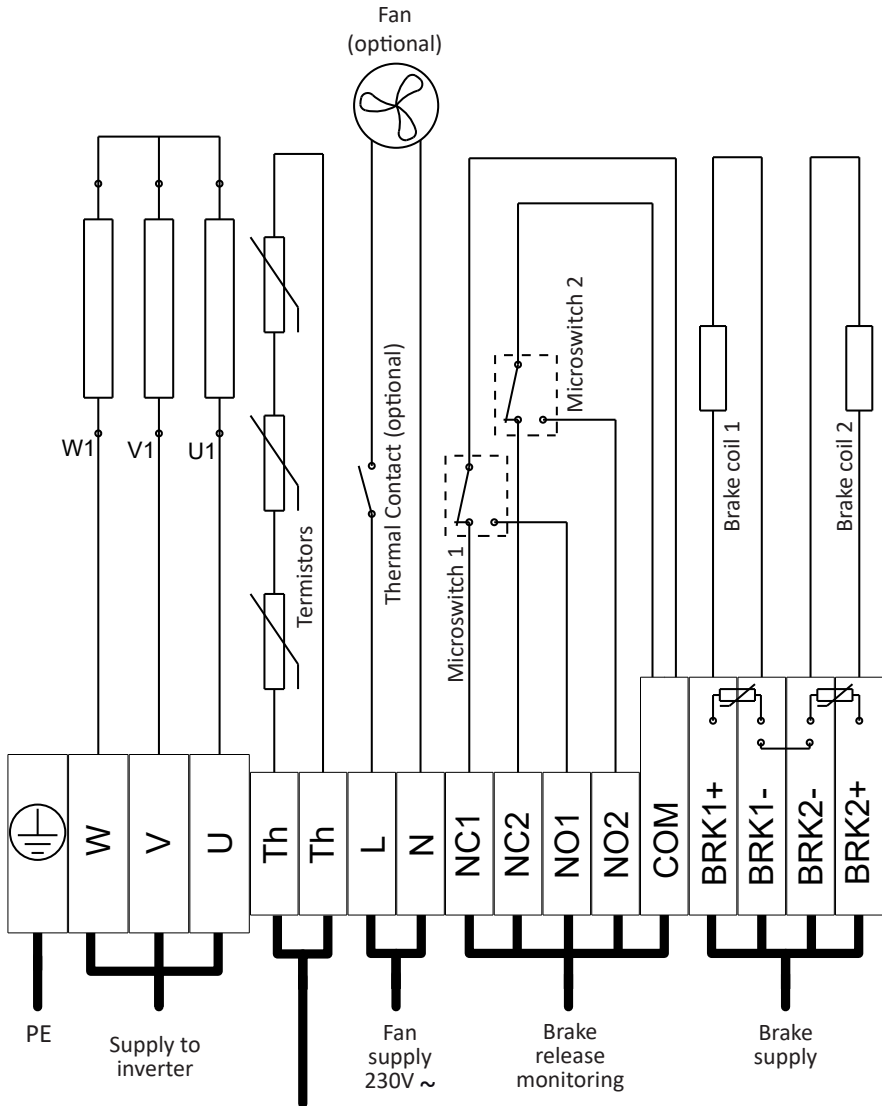

Thermistors  
Warning! don't apply voltages of > 2.5Vdc

### 9.3. ENCODER

The encoder is a digital electronic component that provides the exact position of the rotor. The inverter must be equipped with a specific input able to process the signals coming from the encoder in order to interpret the angular position of the rotor.

There are two types of encoders available:

- Absolute rotary encoder with EnDat interface;
- Rotary encoder with Sin/Cos interface;



Consult the inverter manual in order to chose the correct type of encoder.

The encoder is fixed on the drive shaft in the factory, if the encoder needs to be replaces, refer to section "Encoder replacement" in this manual.



Each time the encoder is mounted on the shaft or tampered with, alignment of the rotor must be repeated by the inverter . Refer to the manual of the inverter installed for this operation.



The encoder is a delicate component, therefore prior to installation and start-up check that the components and cables/pins are in optimum condition and not compromised or damaged.



Encoder contains components that can be damaged by electrostatic discharge.

The installation/maintenance personnel must discharge the electrostatic charge before handling the encoder or the cables/pins by touching a metal object solidly connected to earth.

Avoid any mechanical shock or impact so as not to damage the encoder and thus impair its correct operation.



All electrical connections and connection/disconnection of the connectors must be made with the main switch set to "OFF".



A shielded cable must be used for the connection of the encoder in order to avoid interference and/or signal noise. The pins or wires that are not used must be properly insulated. The encoder power supply cable must be wired separately and not together with the motor/brake power supply cables.

### 9.3.1. ABSOLUTE ROTARY ENCODER CONFIGURATION - ENDAT INTERFACE

HEIDENHAIN ENDAT ECN 1313 ABSOLUTE ENCODER WITH 12 PIN CONNECTOR - MAXIMUM EXTENSION CABLE LENGTH = 25 METRES

The ECN 1313 encoder is an absolute encoder with an EnDat interface and 12 pin connector. The combination of extension cables is necessary in order to connect this encoder to the inverter. The encoder, supply as standard, is connected to connectors C1.



All electrical connections and connection/disconnection of the connectors must be made with the main switch set to "OFF".

Take particular care not to damage the wires or pins in the event the connectors need to be connected or disconnected.

See the encoder manual for further information.

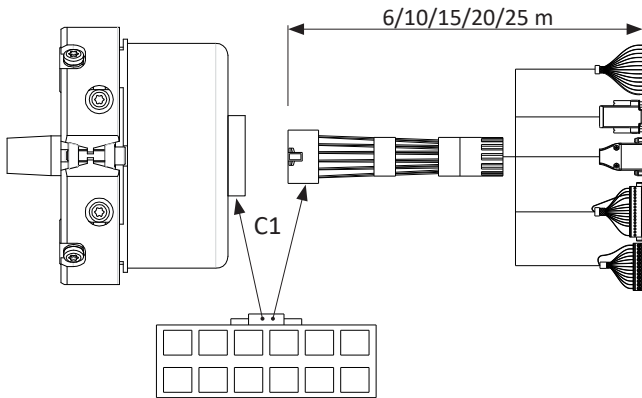

The encoder ECN 1313 may be supplied together with extension cables of variable length up to 25 metres with a different connector.



Consult the inverter manual in order to chose the correct type of inverter side connector.

- EXTENSION CABLE WITHOUT CONNECTOR (INVERTER SIDE) COMBINED WITH ECN 1313 - MAX. EXTENSION CABLE LENGTH = 25 METRES

Please refer to the table below for extension cable connections.

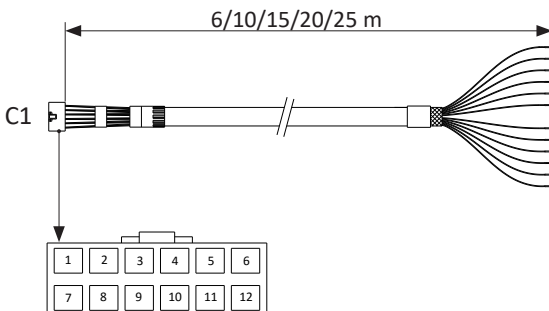

C1 MINITEK 12 PIN		
PIN	WIRE COLOUR	SIGNAL
1	Brown	5 V Up
2	Green	CLOCK
3	Violet	B-
4	White	0 V Up
5	Red/Blue	A-
6	Grey	DATE
7	Pink	DATA-
8	Grey/Pink	A+
9	Blue	Sensor 0 V
10	Black	B+
11	Yellow	CLOCK -
12	Red	Sensor 5 V

## HEIDENHAIN ENDAT ECN 1313 ABSOLUTE ENCODER WITH 17 PIN CONNECTOR - MAXIMUM EXTENSION CABLE LENGTH MORE THAN 25 METRES

The ECN 1313 encoder is an absolute encoder with an EnDat interface, 0.3 m cable and 17 pin connector (C2).

The encoder, supply as standard, is connected to connectors C1.



All electrical connections and connection/disconnection of the connectors must be made with the main switch set to "OFF".

Take particular care not to damage the wires or pins in the event the connectors need to be connected or disconnected.

The combination of extension cables is necessary in order to connect the encoder to the inverter. See the encoder manual for further information.

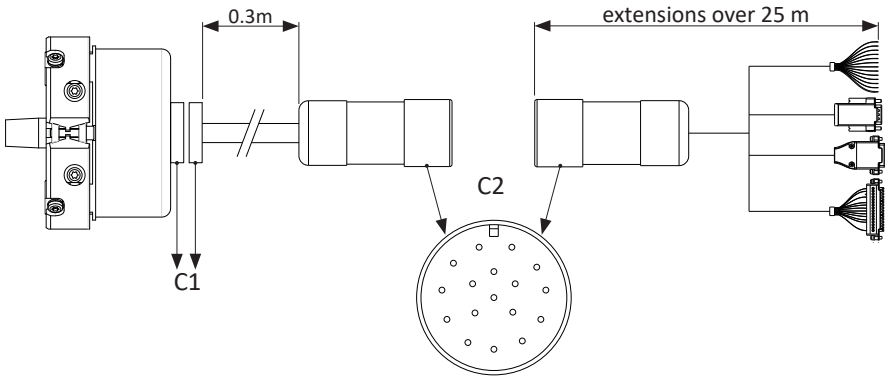

The encoder ECN 1313 may be supplied together with extension cables of variable length of more than 25 metres with a different connector.



Consult the inverter manual in order to chose the correct type of inverter side connector.

- EXTENSION CABLE WITHOUT CONNECTOR (INVERTER SIDE) COMBINED WITH ECN 1313 - EXTENSION CABLE LENGTH OF MORE THAN 25 METRES

Please refer to the table below for extension cable connections.

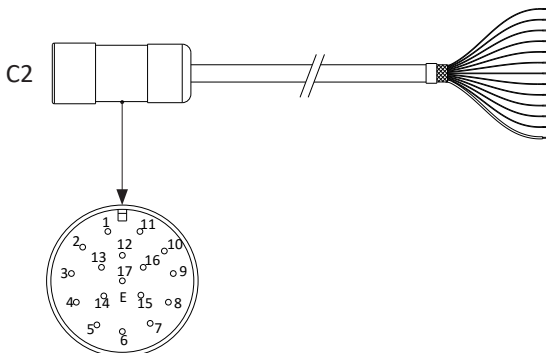

C2 17 PIN		
PIN	WIRE COLOUR	SIGNAL
1	Blue	5 V
2	--	--
3	--	--
4	White	0 V
5	--	--
6	--	--
7	Brown/Green	5 V Up
8	Violet	CLOCK
9	Yellow	CLOCK-
10	White/Green	0 V Up
11	Internal display	--
12	Blue/Black	B+
13	Red/Black	B-
14	Grey	DATE
15	Green/Black	A+
16	Yellow/Black	A-
17	Pink	DATA-

### 9.3.2. ROTARY ENCODER SIN/COS INTERFACE CONFIGURATION

HEIDENHAIN ERN 1387 ABSOLUTE ENCODER WITH 14 PIN CONNECTOR - MAXIMUM EXTENSION CABLE LENGTH = 25 METRES

The ERN 1387 encoder has a SIN/COS interface and a 14 PIN connector (C3). The combination of extension cables is necessary in order to connect this encoder to the inverter.

The encoder, supply as standard, is connected to connectors C3.

Please refer to the table below to connect the encoder to the inverter.



All electrical connections and connection/disconnection of the connectors must be made with the main switch set to "OFF".

Take particular care not to damage the wires or pins in the event the connectors need to be connected or disconnected.

See the encoder manual for further information.

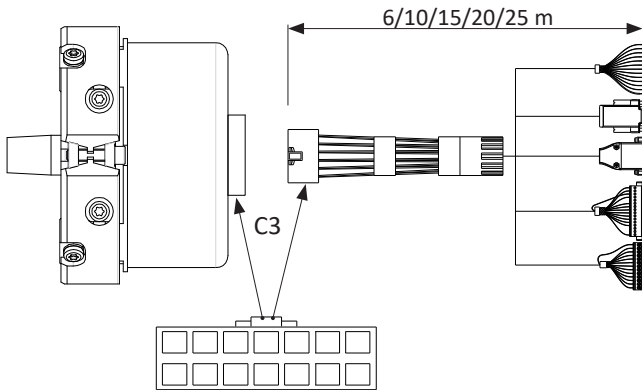

The ERN 1387 encoder may be supplied together with extension cables of variable length up to 25 metres with a different connector.



Consult the inverter manual in order to chose the correct type of inverter side connector.

- EXTENSION CABLE WITHOUT CONNECTOR (INVERTER SIDE) COMBINED WITH ERN 1387 - MAX. EXTENSION CABLE LENGTH = 25 METRES

Please refer to the table below for extension cable connections.

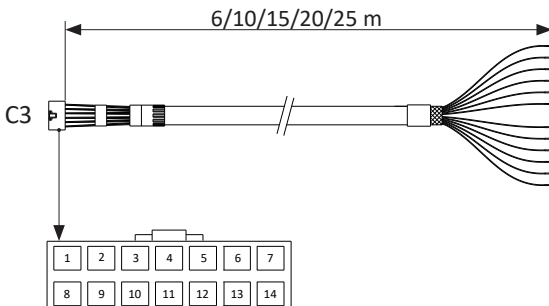

C3 MINITEK 14 PIN		
PIN	WIRE COLOUR	SIGNAL
1	Brown	5 V Up
2	Grey	DATE
3	Black	B+
4	Red	R+
5	White	0 V Up
6	Grey/Pink	A+
7	Green	CLOCK
8	Yellow	CLOCK-
9	Red/Blue	A-
10	--	--
11	Blue	R-
12	Violet	B-
13	Pink	DATA-
14	--	--

### 9.3.3. INSTRUCTIONS FOR INSTALLING THE EXTENSION CABLE ON THE HEIDENHAIN ENDAT ECN 1313 ENCODER

The ECN 1313 encoder is an absolute encoder with an EnDat interface and 12 pin connector. The combination of extension cables is necessary in order to connect the encoder to the inverter. The connection of the extension cable to the encoder is carried out using the 12 PIN connector.



Incorrect assembly of the extension cable may damage it and/or cause incorrect operation of the encoder



To avoid damaging the cable during assembly work, it is important to observe the following instructions scrupulously:

- Remove the protection/cover from the connection seat of the connector;

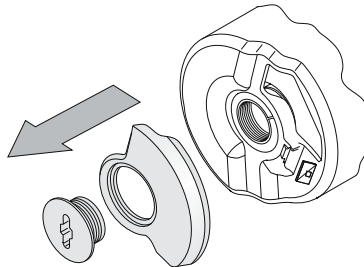

- Connect the 12 PIN connector to the encoder, being careful to insert the tab in the relative seat;

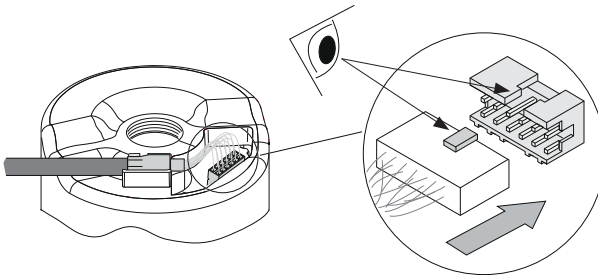

- At an angle of 20°/30° insert the bushing of the extension cable into its seat;

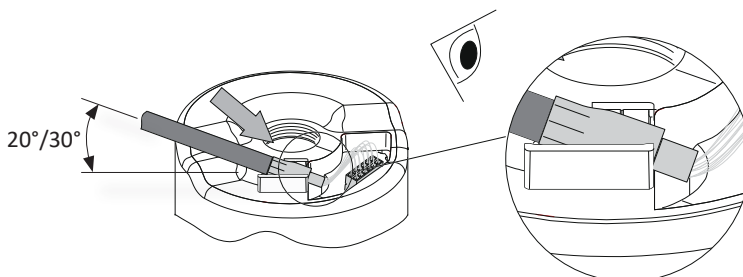



- Lower the bushing of the extension cable and push it fully in.



Incorrect installation could cause irreparable damage to the extension cable

See the images for correct positioning.

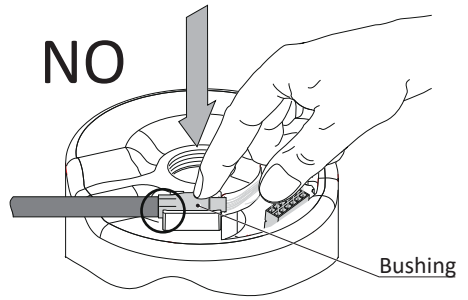
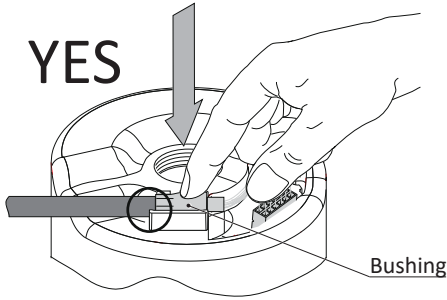

- Fit the protection/cover of the connection seat of the connector;

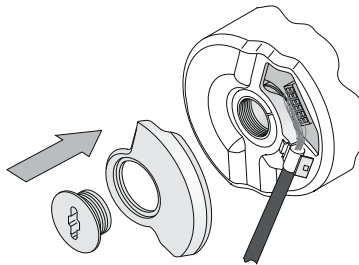

The removal of the extension cable is not recommended, if this is unavoidable carry out the procedure in reverse.

### 9.4. ELECTROMAGNETIC BRAKE

The gearless machines are supplied with a fitted and adjusted electromagnetic brake. The electromagnetic brake is the mechanical braking device for the gearless machine. This device is open (pulley free) when powered and is closed (pulley braked) when it is not powered.

	<p>Verify correct operation after installation. There must be no noise and/or unusual scrapings during motor rotation. Brake release is monitored by micro-switches and <b>MUST</b> be controlled. The two brake circuits <b>MUST</b> be monitored and tested separately.</p>
---	---

These instruction do not in any way replace the technical documentation of the brake attached to this manual.

 Always refer to the electromagnetic brake manual attached to this manual. it lists all functions and operations to be performed in order to intervene safely on the plant.

The rated power voltage may vary in relation to the configuration purchased. The correct value for the rated voltage is indicated on the label affixed directly on to the device itself. Make the electrical connections by connecting the power supply terminals on the control panel as indicated on the screen. The reversal of the polarity does not change the operation of the brake. The brake must be protected against over-voltages. To this end, the standard supply for the gearless machine includes a pair of varistors connected inside the motor's terminal box, parallel to terminals of each coil (for more information, see the wiring diagram at paragraph "terminal board wiring diagram"). The brake is designed to work in a static mode. Dynamic braking is only allowed for emergency braking and braking test purposes. The brake does nor replace the safety braking system used during the descent of the elevator. Correct use does not lead to significant wear of the friction material.

 The brake has been designed with IP10 protection level for operating in dry conditions. The friction material must not come into contact with any type of oil, liquid, grease and/or powder.

 If the friction disc requires replacement, refer to the technical documentation for the brake attached to this manual

## IMPORTANT NOTES



All electrical connections must be made with the main switch in the "OFF" position.



When the device is powered, check that the rated power supply voltage is held at prescribed values.



The tolerance in the supply of voltage to the brake terminals is +5%/-10%. The voltage must be measured on the terminals with the device under power.

A power supply voltage less than the declared rated voltage may compromise the correct operation of the device (no opening or fault closing). A power supply voltage higher than the declared rated voltage may cause super-heating and/or increase intervention times.

The connection cables between the control panel or power supply unit and the brake device must have suitable dimensions to ensure correct operation of the brake. These cables are not included in the standard supply but are optional accessories available on request.

The opening and closing of the brake is monitored by microswitches

In the event of power failure to the brake coil (shaft braked), the contacts of the micro switch are switched to the NC position (Normally Closed); in the event of power to the brake coil (shaft free), the micro switch is switched to the open position.

In order to ensure a long operating lifespan for the contact, the current flowing through it must be between 10mA min. and 50 mA max. at 24V DC.

The maximum electrical lifespan of the micro-switch is only assured in the presence of a resistive load.



If long periods of storage occur the braking surface of the brake could jam on the machine's body causing the shaft to block even with the brake open.

In this case, the brake should be removed, taking care to separate the brake disc from the machine body (refer to the technical documentation attached to this manual for this operation).



To help prevent this phenomenon, it is advisable to power the brake and move the shaft every 3-4 weeks.

When cleaning brake device components, DO NOT use detergents containing solvents and/or oily substances since they may cause irreparable damage to the friction material.

## 9.4.1. EMC DIRECTIVE



The installation and/or construction personnel responsible for the elevator system into which the gearless machine is integrated must check that the assembly of the equipment follow the requirements and meet the current EMC Directive.

## 9.4.2. MANUAL RELEASE LEVER

The standard configuration of the gearless machine does not envisage the supply of the manual brake opening device. This device is available as an optional on request and supplied already installed.



If the manual brake release is supplied, pay close attention to the overall dimensions of the gearless machine since they may vary in relation to the kit purchased. For more details, see paragraph "Dimensions of the gearless machine".



Check the correct operation of the manual brake release device at regular intervals.

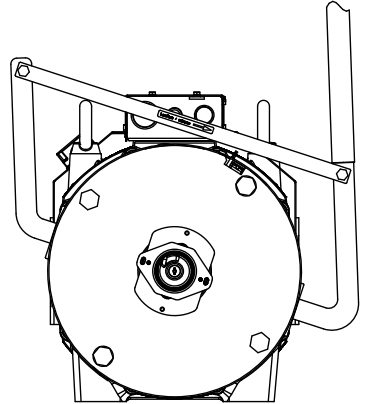

## 9.5. POWER SUPPLY UNIT

Mayr power supply unit (COD.:GEN0190) for electro-magnetic brake.

The brake power supply unit is not included in the standard supply but is an optional accessory available on request.

DIMENSIONS OF THE POWER SUPPLY UNIT:

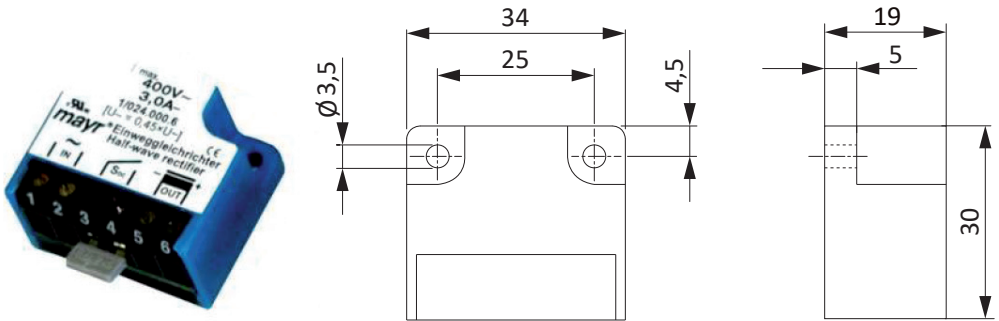

ELECTRICAL FEATURES OF THE POWER SUPPLY UNIT:

Power supply voltage	$U_{AC}$	[VAC]	230	
Output voltage	$U_{bridge}$	[VDC]	207	
Output current	at $\leq 50^{\circ}\text{C}$	$I_{RMS}$	[A]	2.5
	at $\leq 85^{\circ}\text{C}$	$I_{RMS}$	[A]	1.7
Protection varistor	$U_{RMS}$	[V]	275	
Protection fuses			FF315A	
Degree of protection			IP65 components / IP20 terminals	
Terminals			Rated cross-section 1.5 mm <sup>2</sup>	
Operating ambient temperature		[°C]	-25 up to +85	
Storage temperature		[°C]	-25 up to +105	

### 9.5.1. POWER SUPPLY UNIT ELECTRICAL CONNECTION DRAWINGS

#### SLOW INTERRUPTION (LOW SWITCHING NOISE)

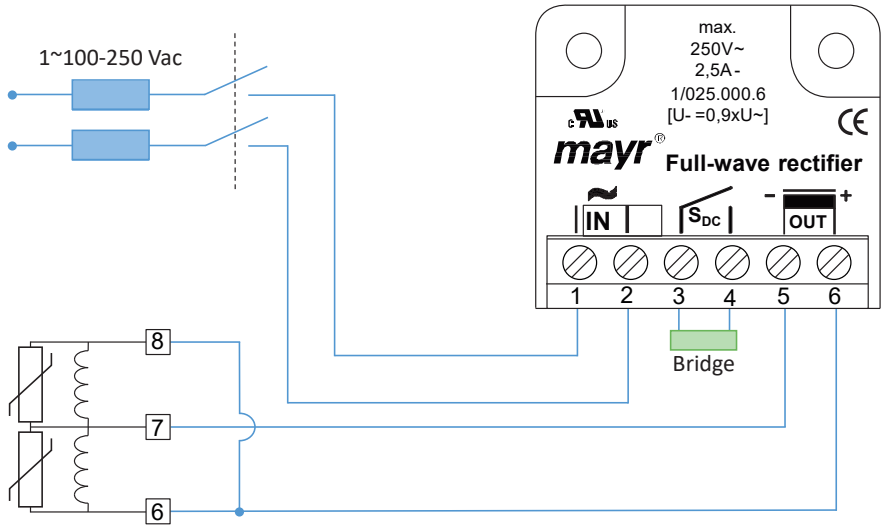

#### FAST INTERRUPTION IN EMERGENCY (HIGH SWITCHING NOISE)

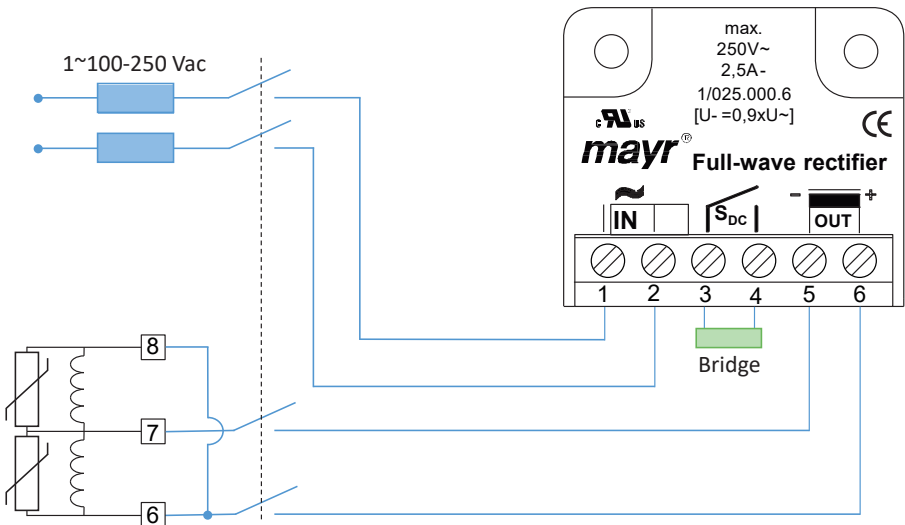

## FAST INTERRUPTION IN EMERGENCY (HIGH SWITCHING NOISE)

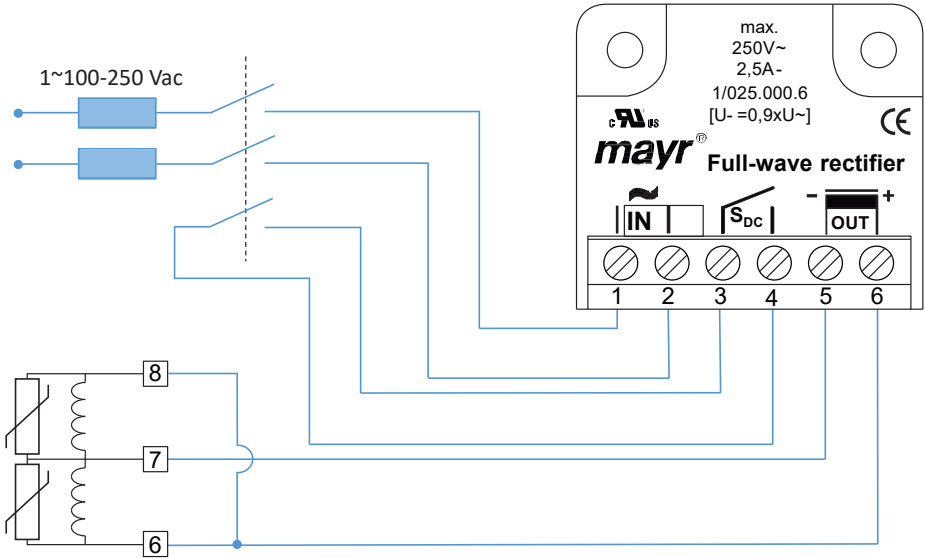

The power supply unit installation position can be defined by the user. You must ensure sufficient heat dissipation by air convection. Do not install the plant near sources of heat.



See the manual of the manufacturer for further information.

## 10. STARTING THE GEARLESS MACHINE FOR THE FIRST TIME

- Verify the correct installation of the machine.
- Check that the electric connections have been made correctly and that the terminal box covers have been put back into position.
- Check the correct masses of the system so that they are in agreement with the machine's design data.



### WARNING

Before performing a motor test ensure that an appropriate safety system is active to prevent movement and/or uncontrolled over-speeding of the system.



### WARNING

Never operate the gearless machine under load when the base fastening screws are not tightened!

May also cause serious damage to machinery or personnel!

- Check the correct setting of the inverter, especially the control parameters (frequency, gain, power, etc...).
- Refer to the inverter use and maintenance manual for the correct parameter settings (for any brand of inverter). Refer to the electrical data indicated on the ID plate of the gearless machine.
- Refer to the brake instructions included for any setting up and/or checks.
- Verify the functionality of the brake and refer to the specific documentation.
- Let the machine rotate with no load in both rotation directions.
- Place the cables in the driving pulley and install suitable safeties in conformity with that stipulated by the EN 81.1 standard.
- The system can now be handled.



## 11. MAINTENANCE

Before performing any maintenance operations, READ CAREFULLY paragraph 7 "Safety requirements" of this manual.

Installation and/or maintenance may only be carried out by competent personnel, authorised to access the machinery and having the necessary equipment and instruments.



### WARNING

Before starting any installation and/or maintenance work, attention must be given to the safety requirements given below in order to avoid accidents and damage to the product components:

- Make sure you have the appropriate personal protection equipment (helmet, body harness, gloves, safety shoes).
- Always secure equipment and other objects to avoid them accidentally falling from a height.
- Make sure that the power has been disconnected before working on electrical equipment.
- Only install the electrical system and/or the connections once you have read the relative instructions.
- Before starting installation, see if there are any structural and space limitations where the installation / maintenance work will be carried out.
- It is advisable to consider where and when you will be operating and which assembly/maintenance procedures you will use.
- Take account beforehand of all significant limitations that may regard the various operation phases and do not start work without first evaluating the consequences.



Installation/maintenance personnel must provide a maintenance plan in relation to the use characteristics of the gearless machine.

The routine maintenance of the gearless machine is limited to:

- General cleaning of the gearless machine (DO NOT USE compressed air)
- Brake adjustment (Brake closed; SYSTEM OUT OF SERVICE) and wear evaluation of the brake materials
- Assessment and checking of wear and tear of pulley grooves
- Checking the correct operation of the manual brake release device, if fitted.



### CAUTION

The gearless machine **MUST NEVER BE OPENED**.

The bearings are lubricated for life (no maintenance required).

See the specific instructions for the removal of the pulley and encoder.

## 11.1. ENCODER REPLACEMENT



Before replacing the encoder:

- read the "Safety Requirements" chapter.
- isolate the electrical power supply of the gearless machine.
- The present instructions do not in any way replace the technical documentation of the encoder attached to this manual.



Always refer to the encoder manual attached to this manual.

Encoder disassembly (figure 1):

- Loosen the screw on the outer ring with an Allen key ①;
- Remove the cover on the rear ②;
- Unscrew the central screw M5x50 by 1-2 turns (approx. 360-720°) ③;
- Carefully screw in a M10 screw until the coupling between the encoder cone and shaft is released ④;
- Remove the M10 screw;
- Complete the removal of the central screw (M5x50) ⑤;
- Remove the encoder ⑥.

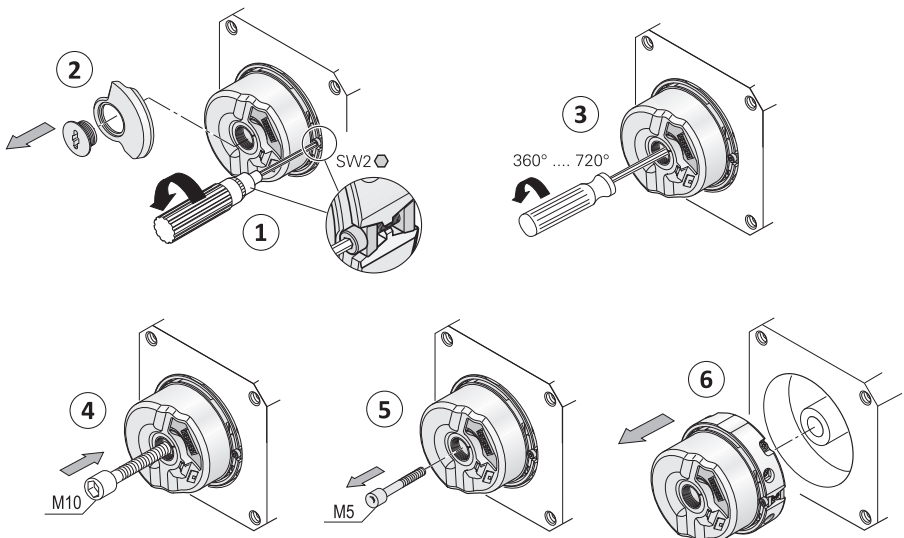

Figure 1

Encoder assembly (figure 2):

- Remove the cover on the rear of the encoder ①;
- Place the encoder inside the housing, taking care to centre the cone properly ②;
- Tighten the central SW4 M5x50 screw with an Allen wrench to a torque of 5 Nm ③;
- Tighten the screw on the outer ring with an Allen wrench SW2 to a torque of 1.25 Nm ④;
- Connect the signal cable (see chapter INSTRUCTIONS FOR INSTALLING THE EXTENSION CABLE ON THE HEIDENHAIN ENDAT ECN 1313 ENCODER) and close the cover with the Allen wrench SW3/SW4 ⑤;
- Once the positioning of the encoder is complete the timing procedure with the inverter must be repeated (REFER TO THE INVERTER MANUAL FOR THE CORRECT PROCEDURE).

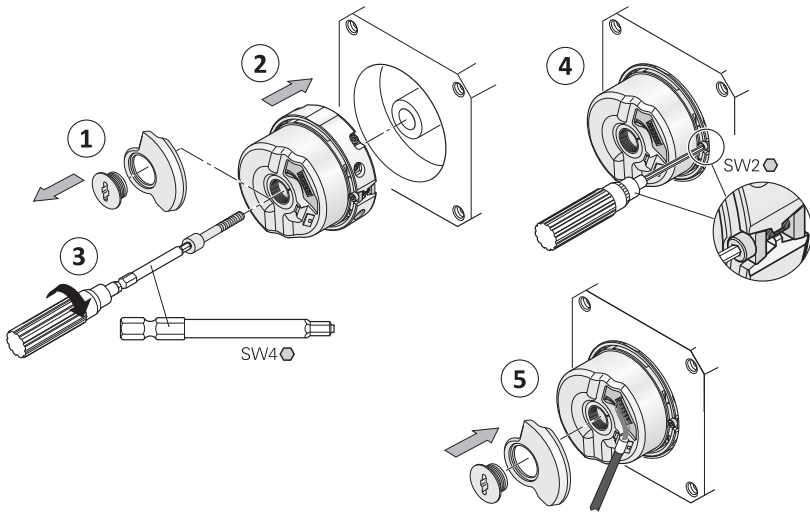

Figure 2

## 11.2. VENTILATION KIT

Possibility of supplying an auxiliary ventilation servo kit as an accessory.

Activation by means of thermo-contact (the thermo-contact is installed inside the terminal box linked to the cast iron body).

Switch ON temperature 60°C, fan switch OFF temperature 45°C.

These temperatures are the value for the machine structure and not the temperature of the motor windings.

### 11.3. PULLEY DISMANTLING



Before dismantling the pulley:

- Read the “Safety Requirements” chapter.
- Isolate the electrical power supply of the gearless machine.
- Remove the guards and cable protection units.
- Place the plant in non-operative conditions and remove the cables from the pulley grooves.

Pulley dismantling:

- Unscrew the retaining screws ① “Figure 3” and place them as shown in “Figure 4”.
- Tighten the nuts ③ on the screws ② and place them as shown in “Figure 4”.
- Tighten the ② screws by 15/20 mm in the threaded holes on the pulley.
- Remove the pulley by tightening in circular sequence the nuts ③, while holding the pulley screws ② firm.

- ① SCREWS M14x50
- ② SCREWS M12x60 (not included in the standard supply)
- ③ NUTS M12 (not included in the standard supply)

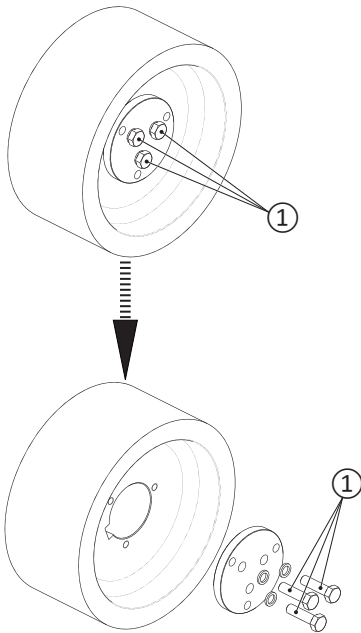

Figure 3

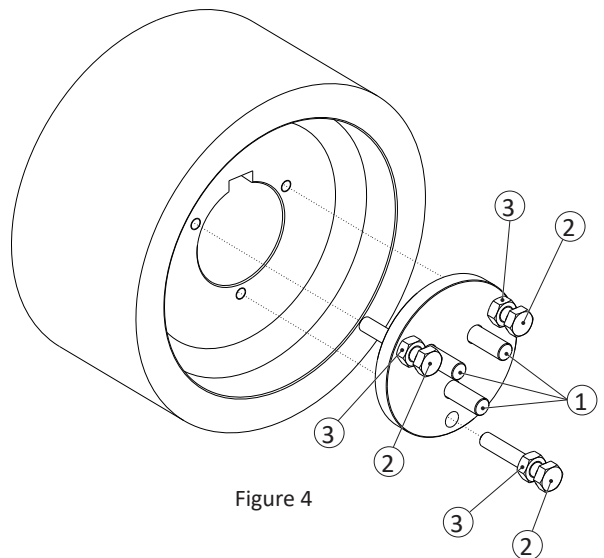

Figure 4

### 11.4. PULLEY ASSEMBLY



Before mounting the pulley:

- read the “Safety Requirements” chapter.
- isolate the electrical power supply of the gearless machine.

Fitting the pulley:

- Check the correct positioning of the tang on the shaft of the gearless machine.
- Carefully clean the taper coupling of the shaft of the gearless machine and the tapered hole in the pulley.
- Align the groove for the hole in the pulley with the tang on the shaft of the gearless machine and insert the pulley on the shaft, pushing it snugly into place.
- Position the securing plate, grower and bolts as shown in “Figure 5”.
- Tighten the bolts ① in circular sequence to a torque of 130 Nm.
- Install the guards and cable protection units (if fitted).

① SCREWS M14x50

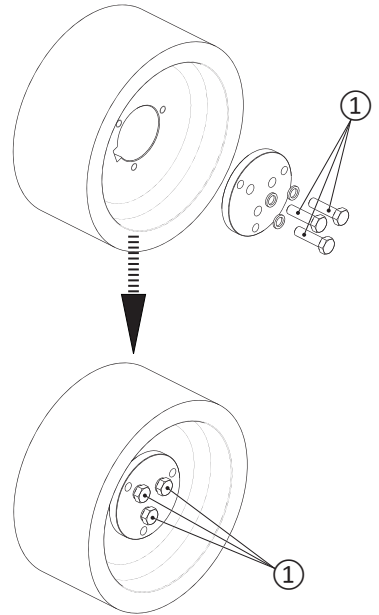

Figure 5

### 12. EMERGENCY OPERATION

The emergency operation is possible by means of an electrical operation.

In the event of mains power failure, emergency operation is possible by opening the brake of the gearless machine.

IN THIS CONDITION THE CABIN WILL MOVE DOWNWARD OR UPWARD DEPENDING ON THE LOAD AND/OR BALANCE CONDITIONS OF THE SYSTEM.



**WARNING**

WHEN THE POWER TO THE MOTOR IS “OFF”, IT IS NOT ABLE TO DEVELOP ANY TORQUE. IN THIS SITUATION, IF THE BRAKE IS OPENED THE CABIN CAN ACCELERATE IN AN UNCONTROLLED MANNER.

For this reason, we recommend that the winding of the motor is kept in short-circuit when the power is OFF. The motor will thereby develop a braking torque proportional to the rotation speed and the current that circulates in the windings will be comparable with the rated one.

In this way we obtain a braking effect comparable to that of a traditional gear (thus the masses are prevented from accelerating uncontrollably).

### 13. DISPOSAL/RECYCLING



Disposal must take place in a workmanlike manner and with respect to the environment, in accordance with the legal regulations in force.



## SICOR S.R.L.

Head Office and Production Centre

Viale Caproni 32 (Industrial Area) 38068 Rovereto (TN) Italy

Ph.. +39 0464 484111 Fax +39 0464 484100

[www.sicoritaly.com](http://www.sicoritaly.com) [info@sicoritaly.com](mailto:info@sicoritaly.com)