

GEARLESS MACHINES

SGP SERIES

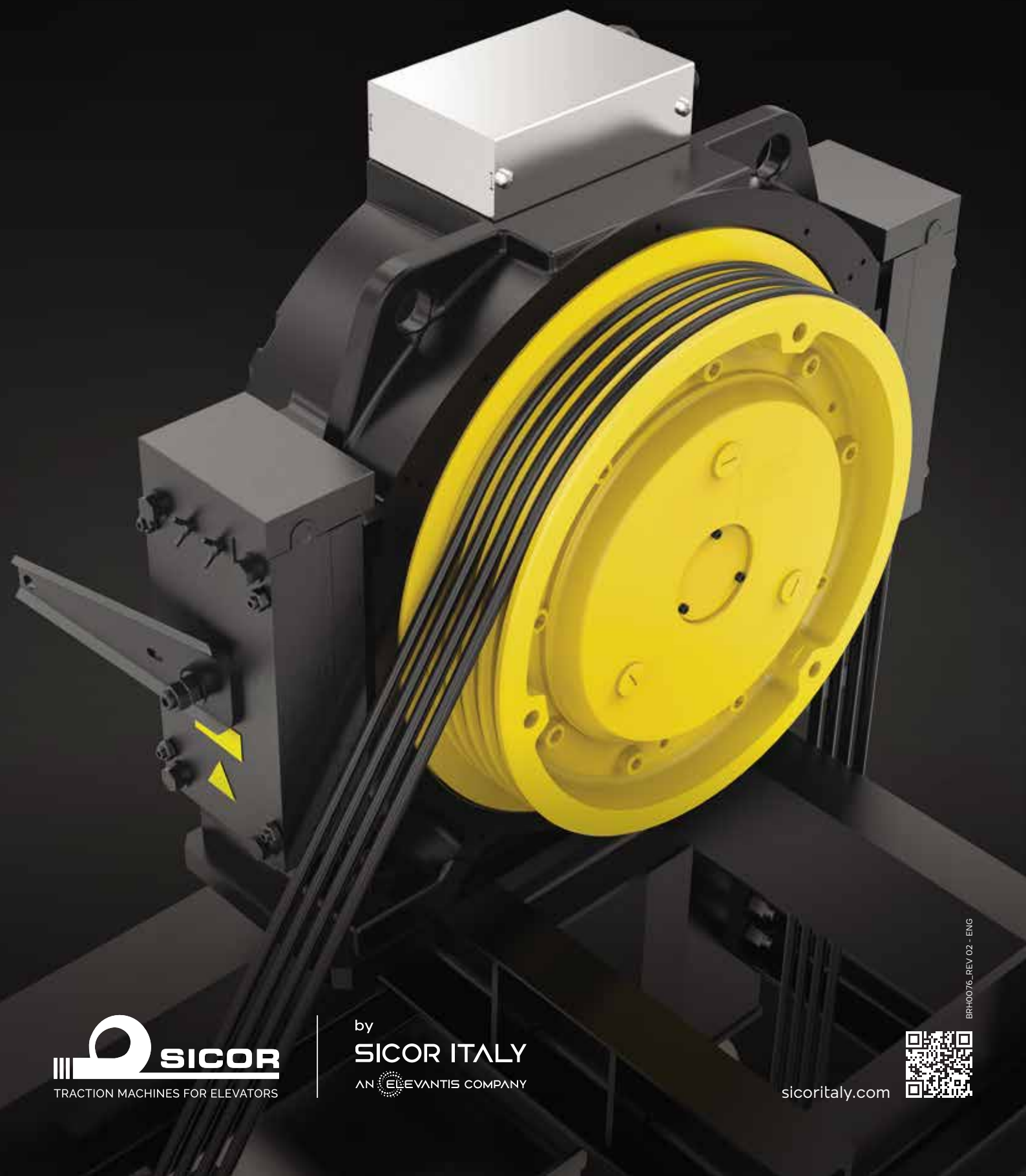



Max Rated Load in 2:1 **1050 kg**
 Max Rated Load in 1:1 **525 kg**



Product SGP 16

Rated torque	[Nm]	669 (S3 -40%)
Braking Torque	[Nm]	2x840
Brake Voltage	[Vdc]	207
Power Range (min/max)	[kW]	3,4 - 11,7
Speed Range	[m/s]	0,5 ... 1,75
Max. Static Load	[kN - kg]	29,4 - 3000
Rated Voltage	[V]	360
Traction Sheave	[mm]	Ø 400
Ropes Diameter	[mm]	8-10
Grooves profile	[]	V with undercut
Pitch	[mm]	16
Poles nr	[]	32
Encoder	[]	ERN1387
Encoder cable: without connector on inverter side	[m]	6
Maximum Weight	[kg]	315

DIMENSIONS

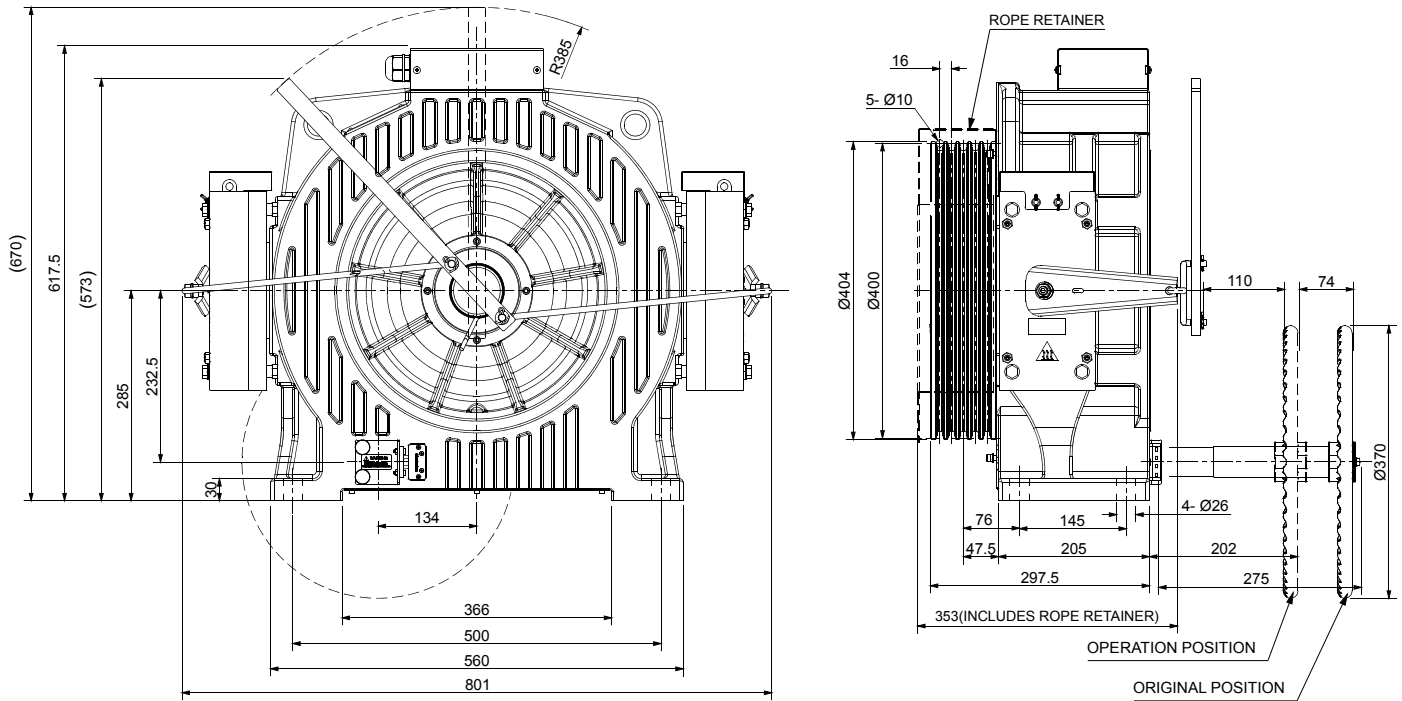

PARTS - ACCESSORIES LIST

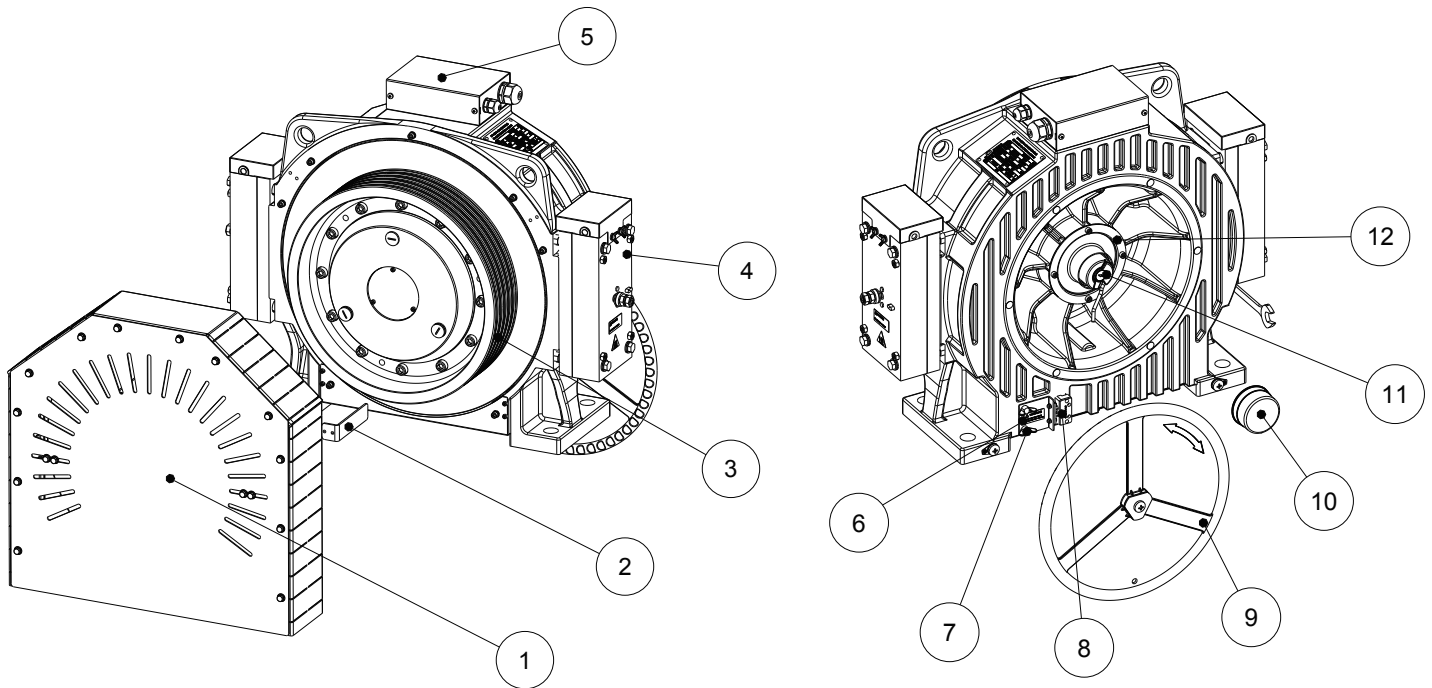

1. Traction sheave protection
2. Rope retainer
3. Traction sheave
4. Brake
5. Terminal box
6. Cover plate
7. Knurled screw
8. Evacuation monitor switch
9. Evacuation hand wheel
10. Encoder protection plate
11. Encoder
12. Encoder assembly flange



by
SICOR ITALY
AN  **ELEVANTIS COMPANY**

Sicor Italy S.R.L.

Viale Caproni, 32 Rovereto (TN) - Italy · Tel: +39 0464 484 111 · info@sicoritaly.com

www.sicoritaly.com