

GEARED MACHINES

SV/SH/MR SERIES

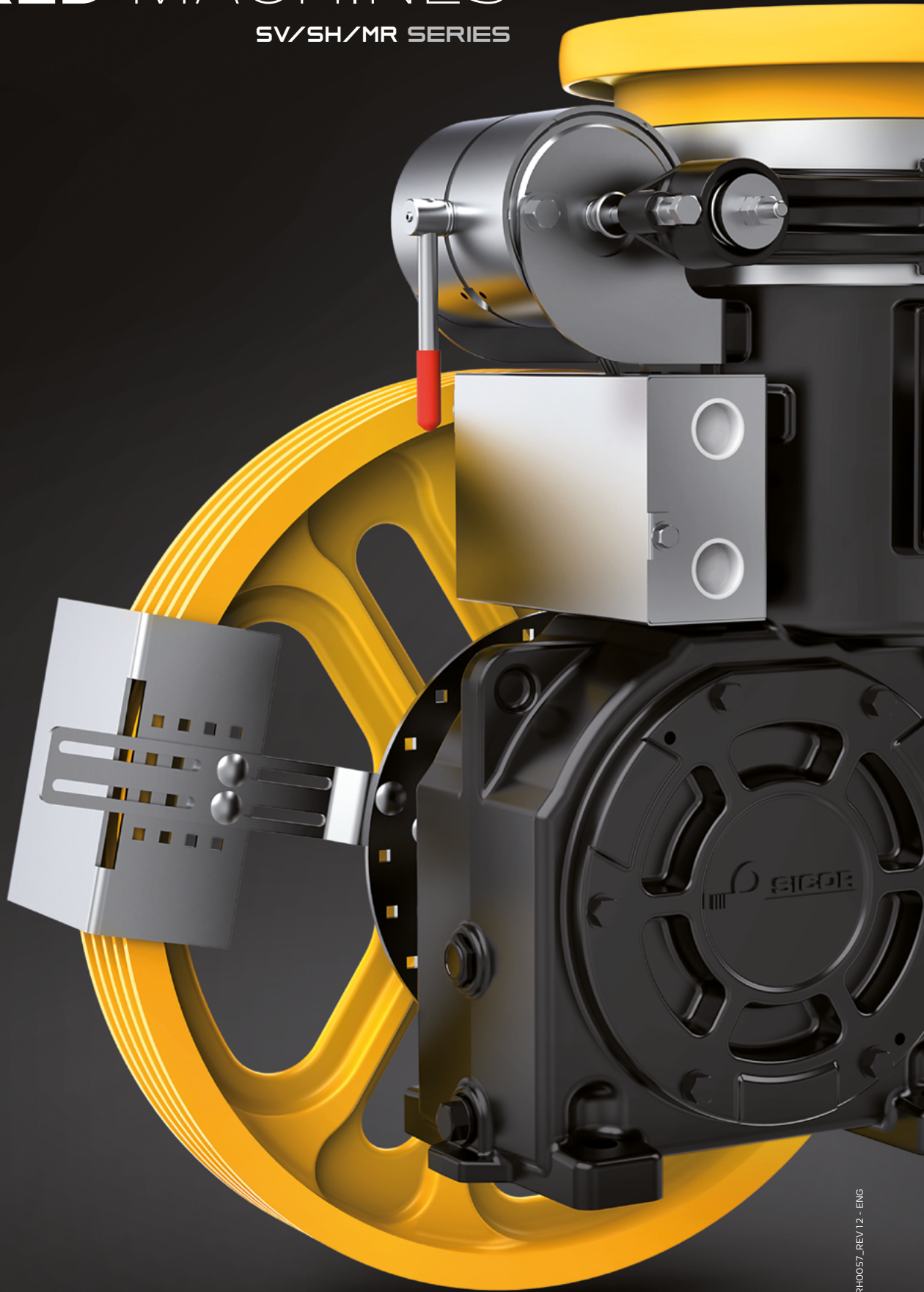



Understanding the market,
anticipating its needs,
making them ours and
building our projects on them.



Sicor, founded in 1981 in Rovereto (TN) as a manufacturer of lifting machines for elevators. Always focused on the application, thanks to a constant process of research and development, Sicor has developed over the years a complete range of products, geared and gearless machines, fit to satisfy the many and varied needs of the market.



Design and production are carried out according to a tested Quality System which guarantees the reliability and performance of the machines.

Each produced motor is subjected to a rigorous final test and quality checks are carried out on all the components.

The test tower allows the verification of machines in the real operating environment of the final customer allowing a perfect set-up.

An innovative online product configurator allows to quickly identify the appropriate traction unit based on the main specifications of the lift system.

Sicor has also certified its quality system, its health and safety management system and its environmental management system according to the most important international standards.

The market needs new answers and Sicor offers them through a new vision, made up of agility, innovation, customer involvement and service quality.

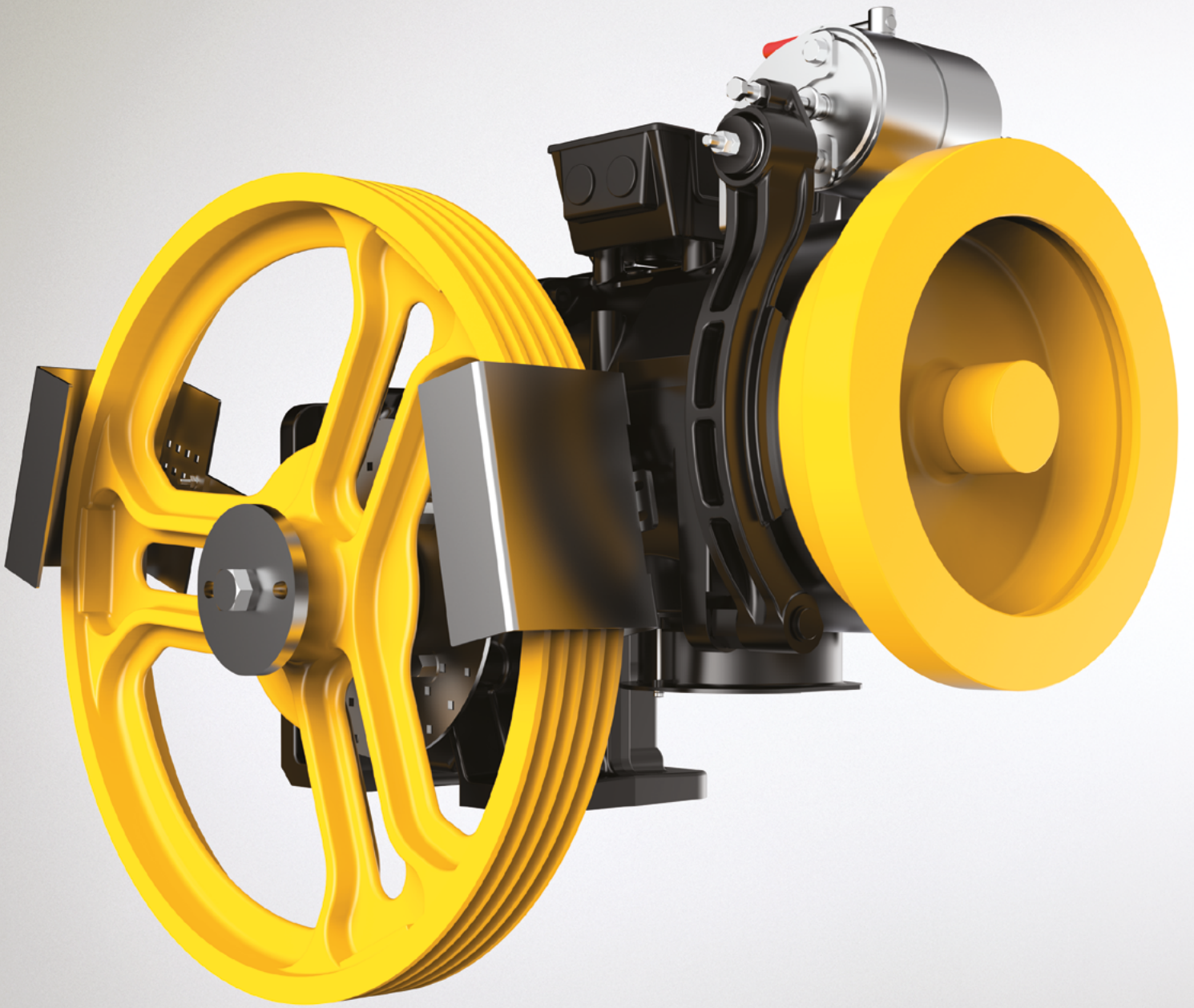

“INDEX”

Features SV/SH/MR series	p.6
Performance	p.8
Product range	p.9
SV110	p.10/17
SH110B	p.18/24
MR12C	p.25/34
SH130	p.35/42
SH130G	p.43/48
SH140	p.49/58
SH140LS	p.59
SH140T	p.60
SH160	p.61/68
SH160LS	p.69
SH160T	p.70/72
SH190	p.73/81
MR21	p.82/91
MR26	p.92/100
MR35	p.101/109
Versions	p.110
Accessories	p.111

SV/SH/MR series features

Model	Power Range [50Hz] min - max [kW]	Power Range [60Hz] min - max [kW]	Max. Static Load [kN - kg]	B	TS	LS	T
SV110	3,6 ÷ 5,5	4 ÷ 6	19,6 - 2000	--	--	--	--
SH110B	2,7 ÷ 5,5	4 ÷ 6	20,6 - 2100	●	--	--	--
MR12C	2,7 ÷ 6,7	4 ÷ 6	25,5 - 2600	--	--	--	--
SH130	2,7 ÷ 7,5	4 ÷ 8,2	25,5 - 2600	●	--	--	--
SH130G	5,5 ÷ 7,5	6 ÷ 8,2	28,5 - 2900	●	--	--	--
SH140	2,7 ÷ 11	4 ÷ 12	32,4-3300	●	--	●	●
SH160	5,1 ÷ 20	5,5 ÷ 18	42,2 - 4300	●	--	●	●
SH190	4,2 ÷ 30	4,7 ÷ 33	51-5200	●	--	--	○
MR21	7,5 ÷ 30	8,2 ÷ 33	72,6 [TS] - 7400 [TS]	●	●	--	--
MR26	11 ÷ 43	11 ÷ 47	80,2 [TS] - 8175 [TS]	●	●	--	--
MR35	20 ÷ 90	22 ÷ 100	139,3 - 14200	--	●	--	--

● Available. ○ On request. -- Not available. **B** Slow shaft brake. **TS** Third support. **LS** Long shaft. **T** Drum.

Sicor geared machines are according to the Directives/
Standards:

2006/42/EC, 2014/33/EU, 2014/30/EU, EN81-20, EN81-50,
EN12015, EN12016, IEC60034-1

- The processes are carried out with CNC precision machines; the components check is carried out with a Zeiss three-dimensional measurement system
- Only use of made in Italy motors with insulation class F, IP21 protection degree, forced ventilation, single and double polarity, at 50Hz and 60Hz
- Traction sheaves in EN-GJS-700-2-UNI EN 1563 (with hardness > 250HB)

- Brake with full redundancy (mechanical as prescribed by EN81-20:2020, but also electrical)
- Safety brake on slow shaft (SSB=Slow Shaft Brake) available on request
- Encoders available on request (can also be assembled on an already installed machine)
- Microswitch kit for controlling the position of the fast shaft brake shoes available on request
- Traction sheave/pulley protections available on request
- Standard machine frame with / without idler pulley available on request
- Each Sicor geared machines is supplied complete with synthetic oil

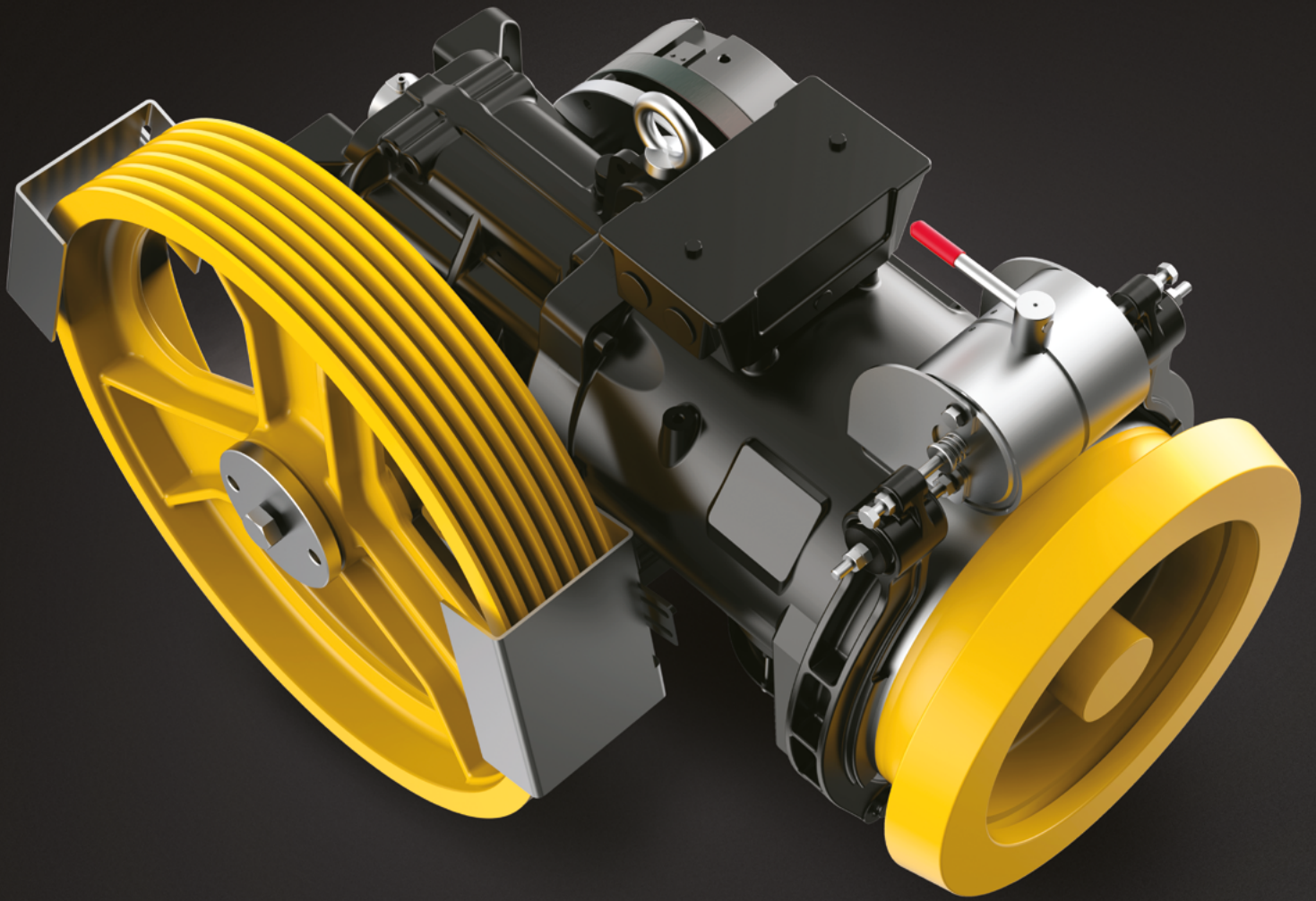

Performance

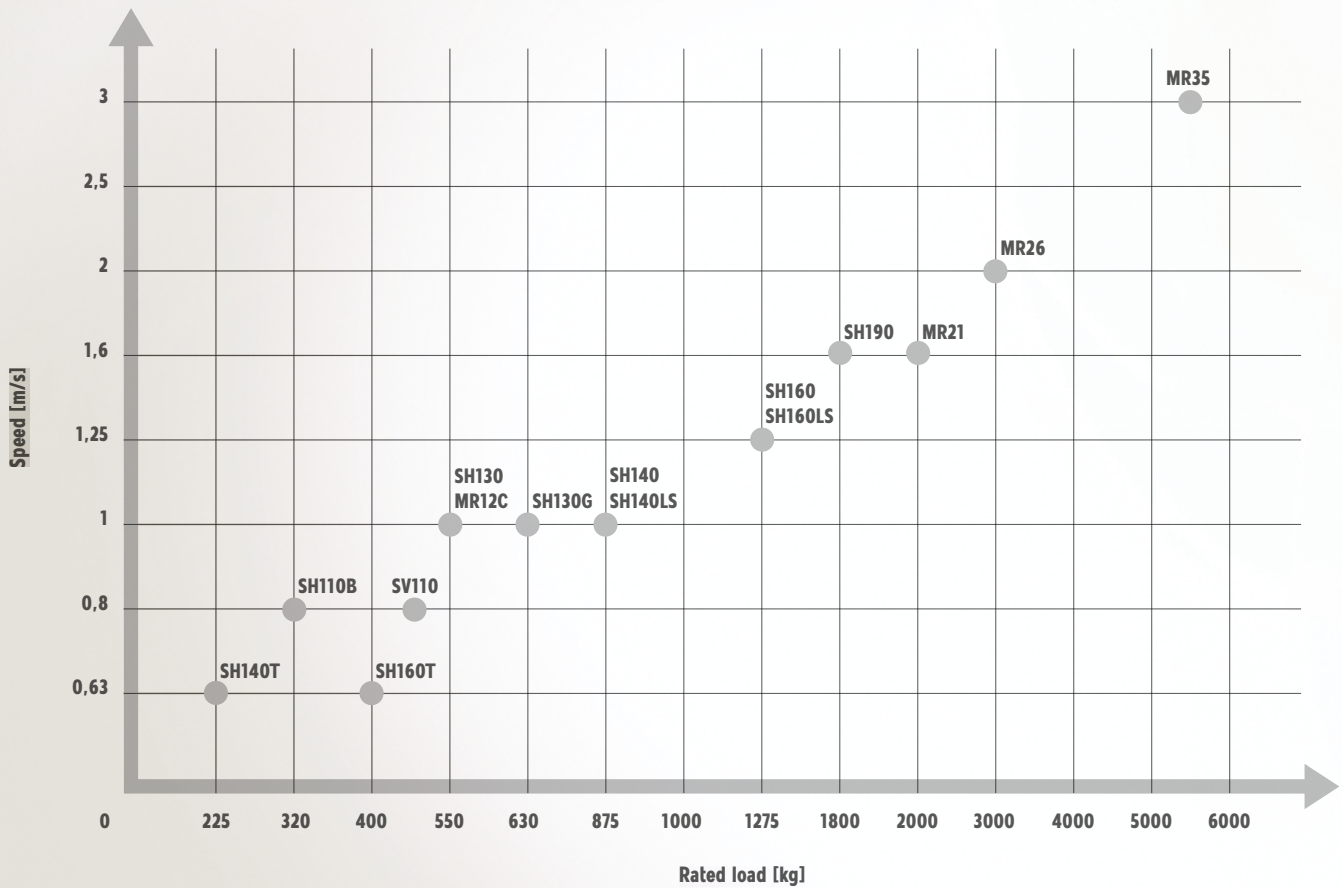

The production range of Sidor geared machines covers rated loads up to 5.500kg in roping 1:1, speeds of up to 4m/s with traction sheaves from 320 to 885mm. Numerous special versions and options are available on request.

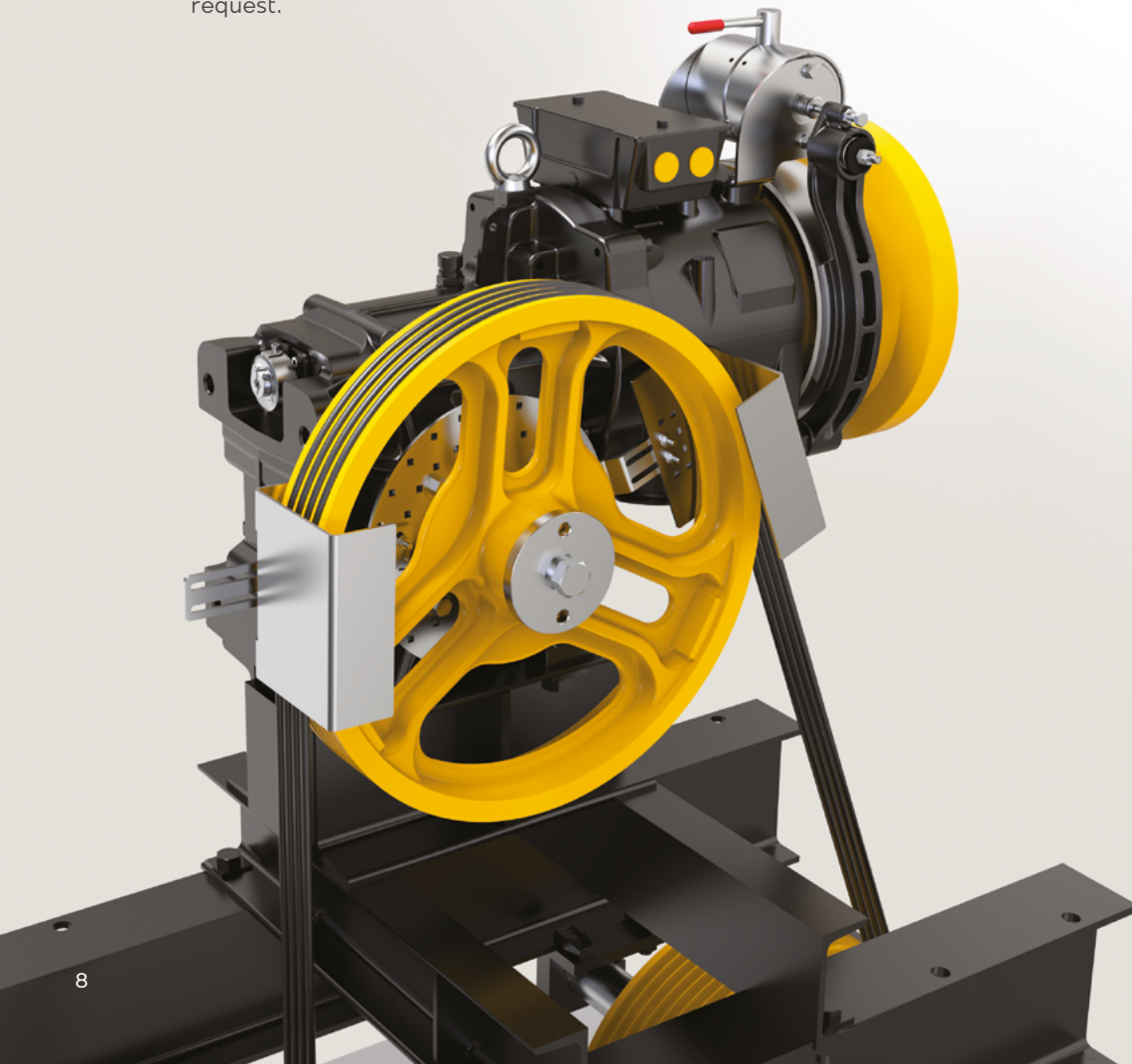

Product range

Roping 1 : 1

Model	For rated loads up to	Speed range synchronous		Traction sheaves diameter	Max Static Load
		[kg]	50Hz [m/s]		
SV110 	450	0,27 ... 1,10	0,27 ... 1,32	480,520,600	19,6 - 2000
SH110B 	400	0,30 ... 2,19	0,37 ... 2,63	320,360,400,450,480,520,550,600	20,6 - 2100
MR12C 	550	0,34 ... 2,19	0,62 ... 2,63	340,420,440,480,550,600	25,5 - 2600
SH130 	550	0,32 ... 3,51	0,39 ... 4,21	320,360,400,450,480,520,550,600,650,700	25,5 - 2600
SH130G 	630	0,72 ... 1,27	0,87 ... 1,53	480,520,550,600	28,4 - 2900
SH140 	875	0,25 ... 3,01	0,31 ... 3,61	360,400,450,480,520,560,600	32,4 - 3300
SH140LS 	875	0,25 ... 3,01	0,31 ... 3,61	360,400,450,480,520,560,600	19,6 - 2000
SH140T 	225	0,60	--	400	--
SH160 	1250	0,43 ... 4,02	0,51 ... 4,83	450,520,560,600,650,700	42,2 - 4300
SH160LS 	1250	0,43 ... 4,02	0,51 ... 4,83	450,520,560,600,650,700	42,2 - 4300
SH160T 	400	0,63	--	400	--
SH190 	1800	0,44 ... 3,76	0,53 ... 4,51	520,600,650,690,750	51 - 5200
MR21 	2000	0,44 ... 3,76	0,53 ... 4,51	520,600,650,690,750	55 - 5600 72,6 - 7400 (TS)
MR26 	3000	0,41 ... 3,43	0,49 ... 4,11	560,600,650,690,750,800	64,7 - 6600 80,2 - 8175 (TS)
MR35 	5500	0,62 ... 3,93	0,75 ... 4,72	690,770,800,885	139,3 - 14200

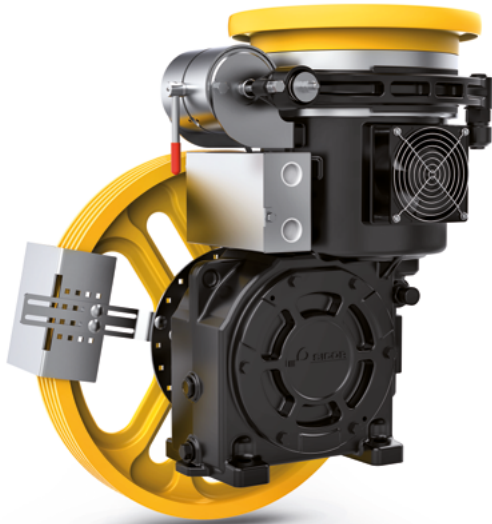

Max. Static Load **19,6 kN - 2000 kg**
 Power Range 50 Hz 4 poles VVVF **4 ÷ 5,5 kW**
 Power Range 50 Hz 6 poles VVVF **3,6 kW**
 Power Range 60 Hz 4 poles VVVF **4,4 ÷ 6 kW**
 Power Range 60 Hz 6 poles VVVF **4 kW**
 Ratio **1/55; 1/43**
 Geared Weight **160 kg**
 Oil capacity **2 l**
 Geared machine **Only vertical**

*The geared machine efficiency values are present above each "rated load" table
 The motor efficiency values are present in the table "electric motor data"*

DIMENSIONS

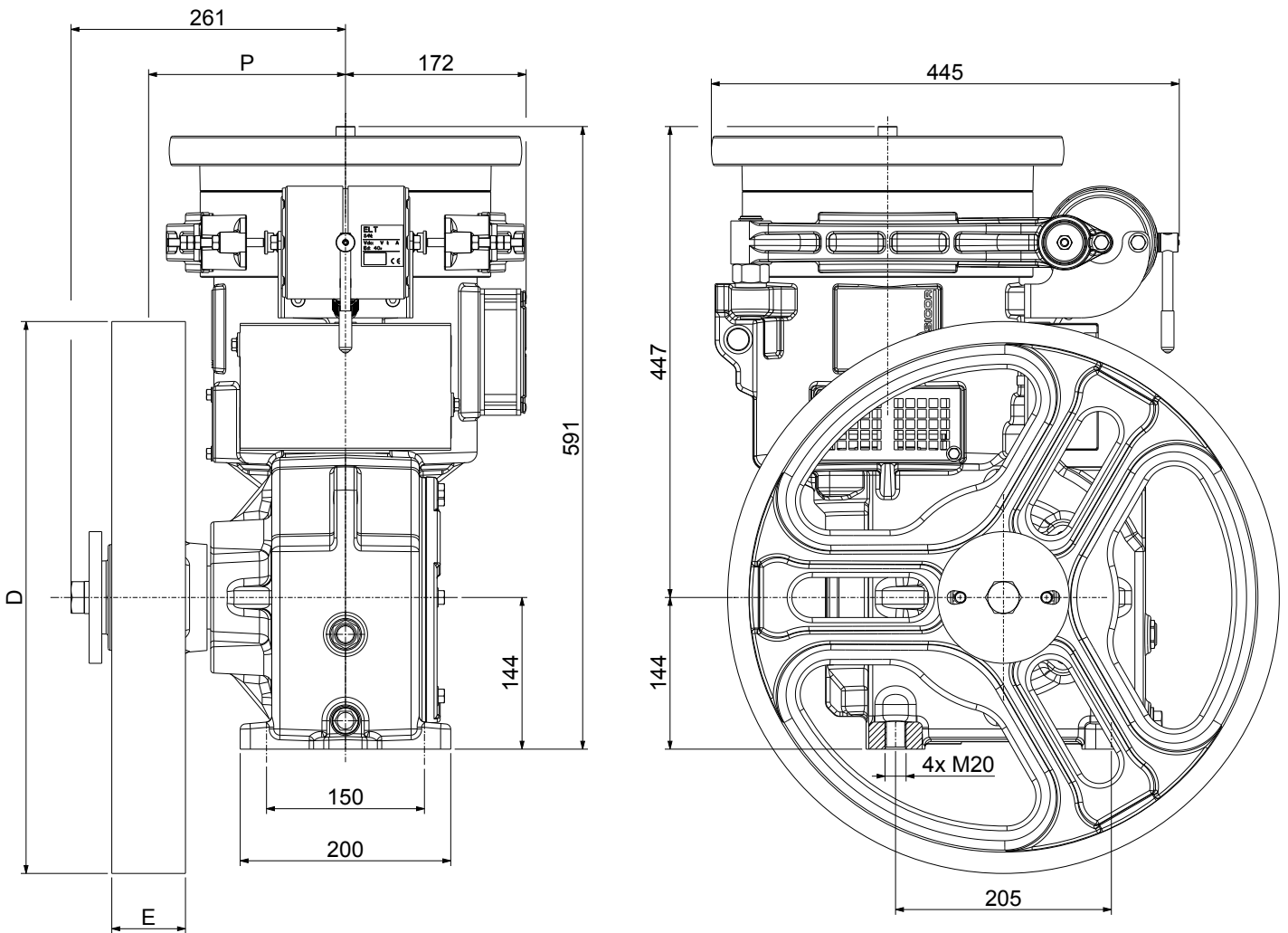

Wrapping System	Traction sheave		Dimension	Load*)	Static Load Direction	Brake Electromagnet		
	D [mm]	E [mm]				[V]	[A]	[W]
CSW	480	70	187	19,6 - 2000	100% $\left\langle \begin{array}{c} \updownarrow \\ \leftarrow \rightarrow \end{array} \right\rangle$ 100% 100%	24	5,25	126
	520					48	2,30	110
	600					60	1,77	106
						80	1,50	120
						110	1,02	112
						200	0,63	126

*) Max. static load on the slow shaft: CSW:Conventional single wrap

DUTY TABLE

Roping 1:1

50Hz					
VVVF 1500 rpm 4 Poles					
Motor Output [kW]					
				VVVF 4	VVVF 5,5
R.R.	Traction Sheave Ø	Speed syn.	Frequency	Max Rated Load	
[i]	[mm]	[m/s]	[Hz]	[kg]	[kg]
1/55	480	0,27	20	460	460
1/55	480	0,34	25	460	460
1/55	480	0,41	30	460	460
1/55	480	0,48	35	460	460
1/55	480	0,55	40	460	460
1/55	480	0,62	45	460	460
1/55	480	0,69	50	460	460
1/55	520	0,74	50	425	425
1/55	600	0,77	45	365	365
1/43	480	0,79	45	475	475
1/43	480	0,84	48	475	475
1/43	480	0,88	50	475	475
1/43	520	0,91	48	435	435
1/43	520	0,95	50	435	435
1/43	600	1,05	48	380	380
1/43	600	1,10	50	380	380

60Hz					
VVVF 1800 rpm 4 Poles					
Motor Output [kW]					
				VVVF 4,4	VVVF 6
R.R.	Traction Sheave Ø	Speed syn.	Frequency	Max Rated Load	
[i]	[mm]	[m/s]	[Hz]	[kg]	[kg]
1/55	480	0,27	20	460	460
1/55	480	0,34	25	460	460
1/55	480	0,41	30	460	460
1/55	480	0,48	35	460	460
1/55	480	0,55	40	460	460
1/55	480	0,62	45	460	460
1/55	480	0,69	50	460	460
1/55	480	0,75	55	460	460
1/55	520	0,82	55	425	425
1/55	480	0,82	60	460	460
1/43	480	0,88	50	475	475
1/55	520	0,89	60	425	425
1/43	480	0,96	55	475	475
1/43	480	1,00	57	475	475
1/43	480	1,05	60	475	475
1/43	520	1,10	58	435	435
1/43	520	1,14	60	435	435
1/43	600	1,21	55	380	380
1/43	600	1,27	58	380	380
1/43	600	1,32	60	380	380

50Hz			
Motor Output [kW]			
		VVVF 4	VVVF 5,5
R.R.	Max Output Torque	Geared Efficiency	
[i]	[Nm]		
1/55	680	0,72	0,74
1/43	700	0,74	0,76

60Hz			
Motor Output [kW]			
		VVVF 4,4	VVVF 6
R.R.	Max Output Torque	Geared Efficiency	
[i]	[Nm]		
1/55	680	0,71	0,73
1/43	700	0,73	0,76

Rated load values listed in the table include the weight of the ropes.
 To know the theoretical load, subtract the weight of the ropes.
 Position Of The Geared = Top Counterweight = 50% Plant efficiency = 0,80

50Hz				
VVVF 1000 rpm 6 Poles				
Motor Output [kW]				
R.R.	Traction Sheave Ø	Speed syn.	Frequency	Max Rated Load
[i]	[mm]	[m/s]	[Hz]	[kg]
1/55	480	0,18	20	460
1/55	520	0,20	20	425
1/55	480	0,23	25	460
1/55	520	0,25	25	425
1/55	480	0,27	30	460
1/55	520	0,30	30	425
1/55	480	0,32	35	460
1/55	520	0,35	35	425
1/55	480	0,37	40	460
1/55	520	0,40	40	425
1/55	520	0,45	45	425
1/55	480	0,46	50	460
1/55	520	0,50	50	425
1/43	480	0,53	45	505
1/55	600	0,57	50	365
1/43	480	0,58	50	505
1/43	520	0,63	50	470
1/43	600	0,66	45	405
1/43	600	0,73	50	405

50Hz		
Motor Output [kW]		
R.R.	Max Output Torque	Geared Efficiency
[i]	[Nm]	
1/55	680	0,74
1/43	700	0,76

60Hz				
VVVF 1200 rpm 6 Poles				
Motor Output [kW]				
R.R.	Traction Sheave Ø	Speed syn.	Frequency	Max Rated Load
[i]	[mm]	[m/s]	[Hz]	[kg]
1/55	480	0,27	30	460
1/55	520	0,30	30	425
1/55	480	0,32	35	460
1/55	520	0,35	35	425
1/55	480	0,37	40	460
1/55	520	0,40	40	425
1/55	520	0,45	45	425
1/55	480	0,50	55	460
1/43	480	0,53	45	505
1/55	480	0,55	60	460
1/55	600	0,57	50	365
1/55	520	0,59	60	425
1/55	600	0,63	55	365
1/43	480	0,64	55	505
1/43	600	0,66	45	405
1/55	600	0,69	60	365
1/43	480	0,70	60	505
1/43	600	0,73	50	405
1/43	520	0,76	60	470
1/43	600	0,80	55	405
1/43	600	0,88	60	405

60Hz		
Motor Output [kW]		
R.R.	Max Output Torque	Geared Efficiency
[i]	[Nm]	
1/55	680	0,73
1/43	700	0,76

Rated load values listed in the table include the weight of the ropes.

To know the theoretical load, subtract the weight of the ropes.

Position Of The Geared = Top Counterweight = 50% Plant efficiency = 0,80

ELECTRIC MOTOR DATA

		50Hz		
		VVVF 1500 rpm 4 Poles	VVVF 1000 rpm 6 Poles	
		Asynchronous Rated Power [kW]		
		VVVF 4	VVVF 5,5	VVVF 3,6
		Motor Parameters		
Rated Voltage (star connection) ^{(1) (3)}	[V]	400	400	400
Frequency	[Hz]	50	50	50
Synchronous Speed	[rpm]	1500	1500	1000
Asynchronous Speed	[rpm]	1423	1424	962
Rated Current ⁽²⁾	[A]	9,4	12,4	10,9
Rated Torque	[Nm]	26,8	36,9	35,7
Cos ϕ Power Factor	[]	0,76	0,78	0,62
Starting Current	[A]	41	51	43
Starting Torque	[Nm]	54	78	80
Duty Cycle	[%]	60	60	60
Starts per Hour	[s/h]	240	240	240
Insulation Class	[]	F	F	F
Degree of Protection IP	[]	IP21	IP21	IP21

(1) The motors are standard supplied with star connection (Y), the customer can arrange a delta connection (Δ).

(2) The indicated current values are related to 400V voltage. For current values with delta connection, multiply the values by 1,732.

(3) The standard supply voltage is suitable for 380-400V/220-230V power supplies.

The geared machine includes a fan, 1~220...240V, 50/60Hz.

Available on request 115V supply voltage.

		60Hz		
		VVVF 1800 rpm 4 Poles	VVVF 1200 rpm 6 Poles	
		Asynchronous Rated Power [kW]		
		VVVF 4,4	VVVF 6	VVVF 4
		Motor Parameters		
Rated Voltage (star connection) ^{(1) (3)}	[V]	400	400	400
Frequency	[Hz]	60	60	60
Synchronous Speed	[rpm]	1800	1800	1200
Asynchronous Speed	[rpm]	1714	1708	1138
Rated Current ⁽²⁾	[A]	10,2	15,2	12,4
Rated Torque	[Nm]	24,5	33,5	33,6
Cos ϕ Power Factor	[]	0,75	0,7	0,6
Starting Current	[A]	48	70	49
Starting Torque	[Nm]	44	70	62
Duty Cycle	[%]	60	60	60
Starts per Hour	[s/h]	240	240	240
Insulation Class	[]	F	F	F
Degree of Protection IP	[]	IP21	IP21	IP21

(1) The motors are standard supplied with star connection (Y), the customer can arrange a delta connection (Δ).

(2) The indicated current values are related to 400V voltage. For current values with delta connection, multiply the values by 1,732.

(3) The standard supply voltage is suitable for 380-400V/220-230V power supplies.

The geared machine includes a fan, 1~220...240V, 50/60Hz.

Available on request 115V supply voltage.

Wrapping System	Traction sheave		Max n° Grooves x D	Grooves Pitch
	D [mm]	E [mm]	n° x mm	l [mm]
CSW	480	70	5xD8	14
	480	70	4xD9	17
	480	70	4xD10	17
	480	70	4xD11	17
	480	70	3xD12	19
	520	70	5xD8	14
	520	70	4xD9	17
	520	70	4xD10	17
	520	70	4xD11	17
	520	70	3xD12	19
	520	70	3xD13	19
	600	70	5xD8	14
	600	70	4xD9	17
	600	70	4xD10	17
	600	70	4xD11	17
	600	70	3xD12	19
	600	70	3xD13	19

VCI

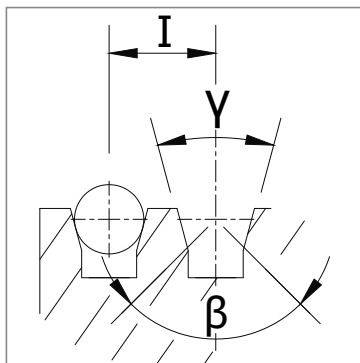

V grooves with undercut

UCI

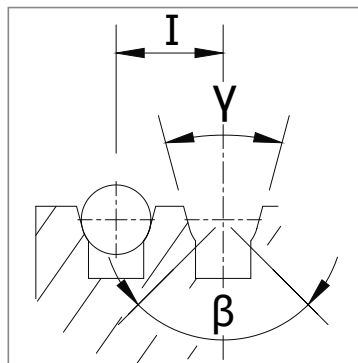

U grooves with undercut

γ = groove angle
 β = undercut angle
 I = grooves pitch

BEDPLATE | TOP MACHINE WITHOUT DIVERTING PULLEY FOR CSW WRAPPING

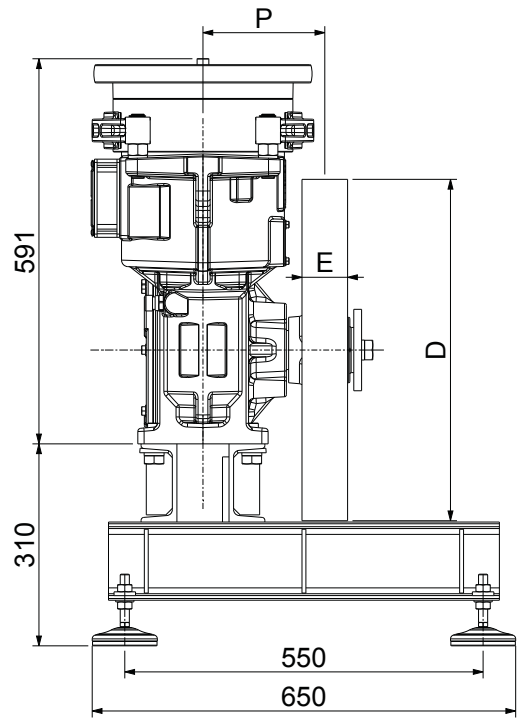
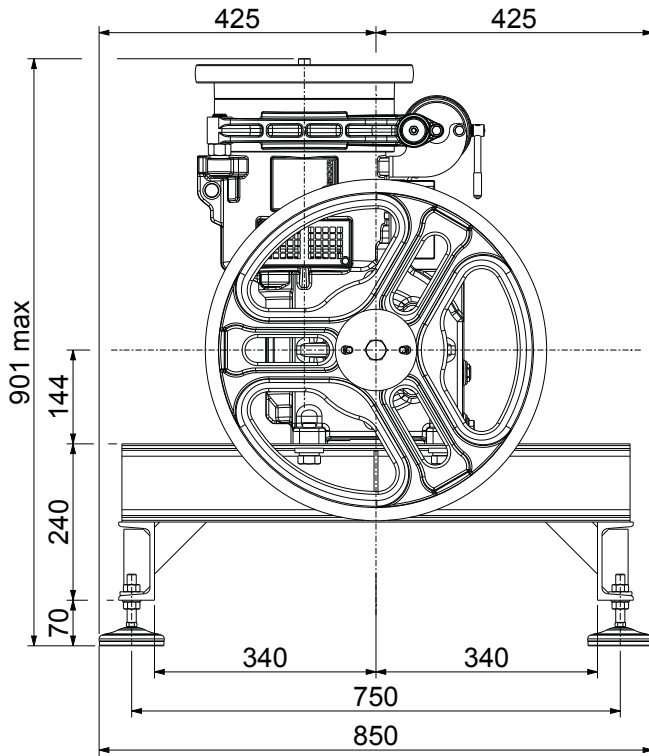

XTE0456 (included vibration dampers)
 Weight of machine bedplate: 49 kg
 (bedplate + vibration dampers)

VIBRATIONS DAMPER SET UP FOR MACHINE BEDPLATE

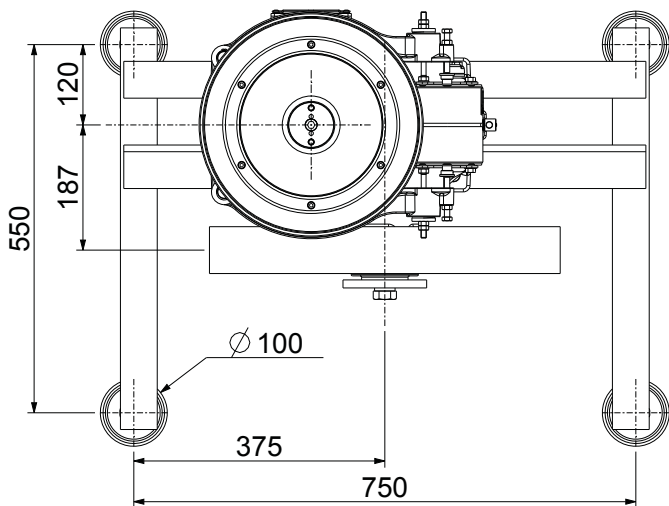

Damper Dimension	Dimension [mm]
TAI0110	D.100x28

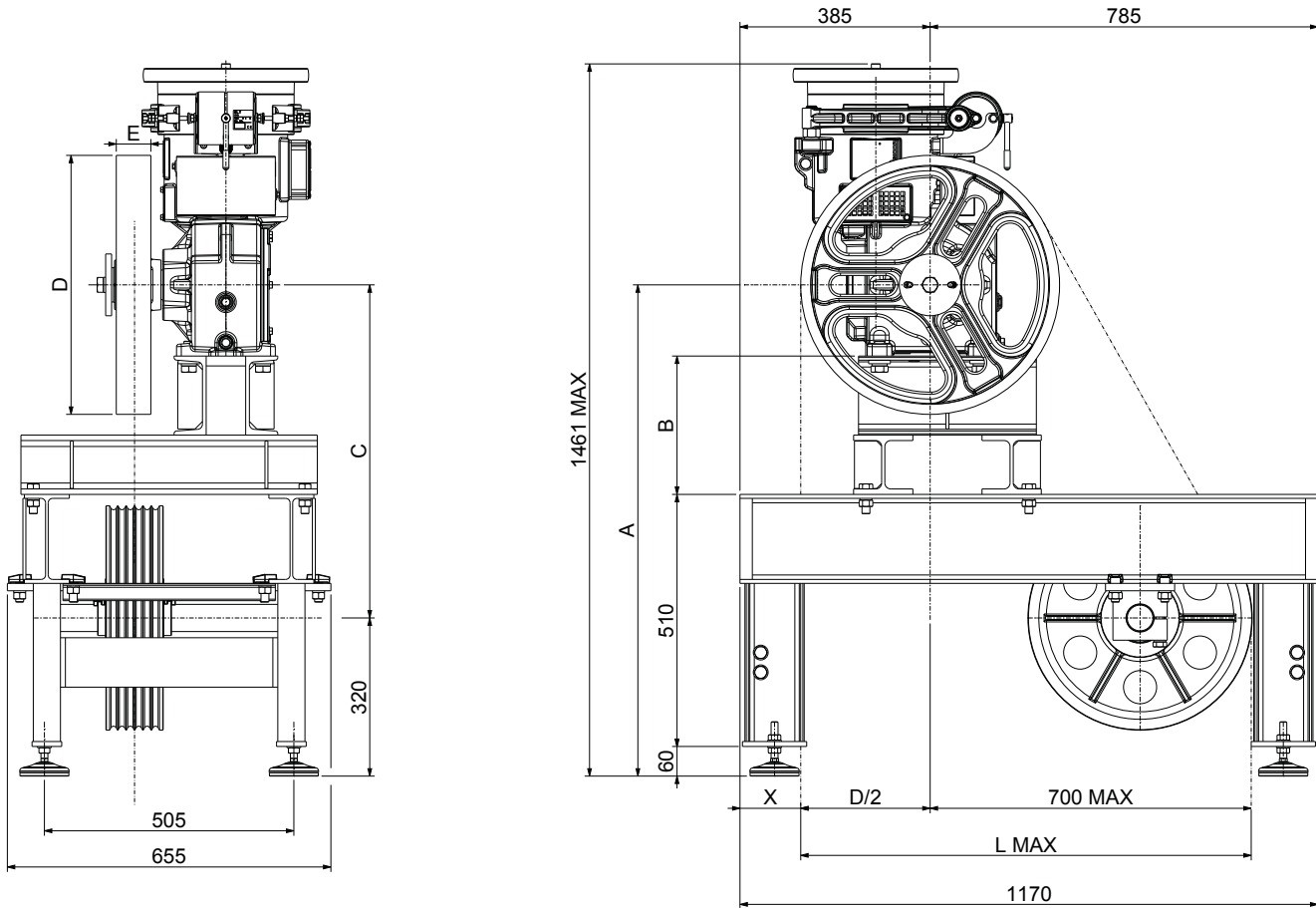

Traction Sheave	X	L max
D [mm]	[mm]	[mm]
480	140	940
520	120	960
600	80	1000

Diverting Pulley	A	B	C
Dt [mm]			
400	994	280	674
450	994	280	674
520	1014	300	694

XTE0516 (Dt 520)–XTE0517 (Dt 400-450) (included vibration dampers)
 Weight of machine bedplate: (XTE0516) 163 kg, (XTE0517) 153Kg
 (bedplate + diverting pulley + vibration dampers)

VIBRATIONS DAMPER SET UP FOR MACHINE BEDPLATE XTE0516 AND XTE0517

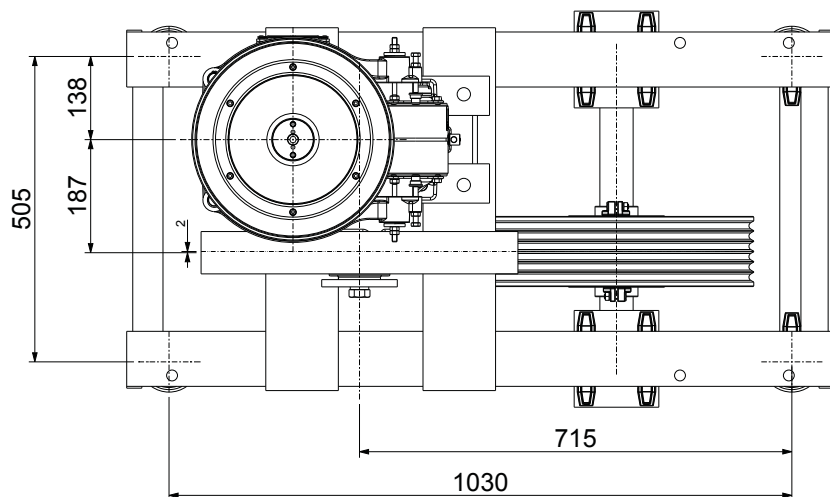

Damper Code	Dimension
	[mm]
TAI0110	D.100x28

DIVERTING PULLEYS AND GROOVES NUMBER x ROPES DIAMETER

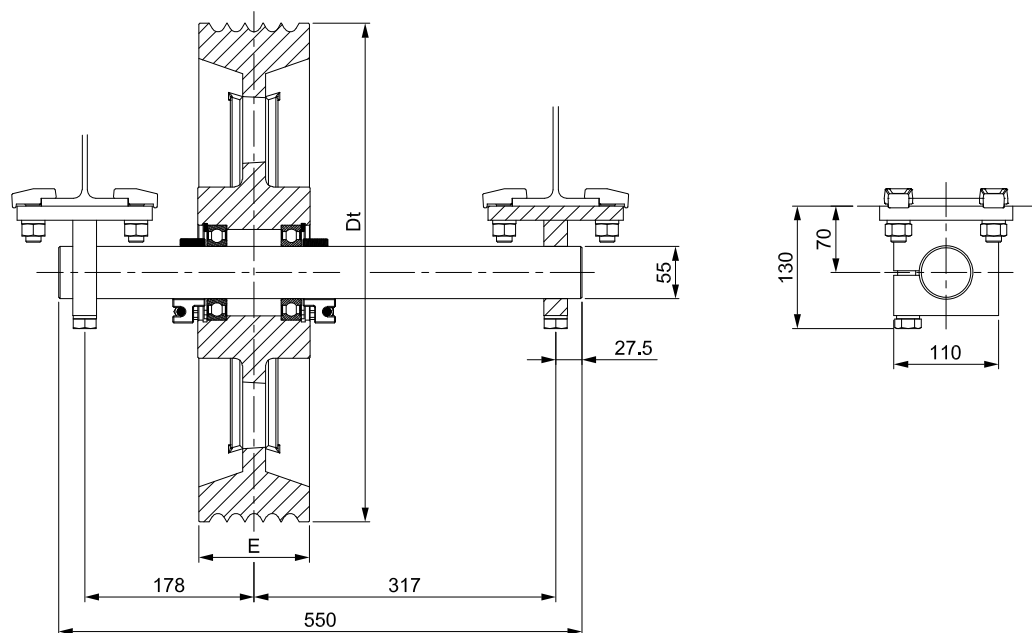

Diverging Pulley		Max n°Grooves x D	Grooves Pitch
Dt [mm]	E [mm]	n° x mm	l [mm]
400	116	7xD8	14
450	116	6xD11	17
520	116	5xD13	19



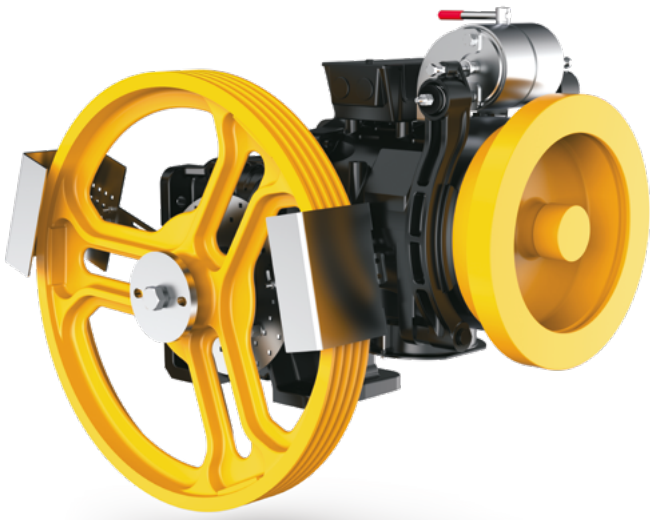

Max. Static Load	20,6 kN - 2100 kg
Power Range 50 Hz 4 poles VVVF	4 ÷ 5,5 kW
Power Range 50 Hz 4/16 poles	4 kW
Power Range 50 Hz 6 poles VVVF	2,7 ÷ 3,6 kW
Power Range 50 Hz 6/16 poles	2,7 kW
Power Range 60 Hz 4 poles VVVF	4,4 ÷ 6 kW
Power Range 60 Hz 4/16 poles	4,4 kW
Power Range 60 Hz 6 poles VVVF	4 kW
Ratio	1/55; 1/43; 2/43; 2/55
Geared Weight	200 kg
Oil capacity	2,9 l
Geared machine Rh o Lh (from motor side)	Image ref. to Lh geared

The geared machine efficiency values are present above each "rated load" table
 The motor efficiency values are present in the table "electric motor data"

DIMENSIONS

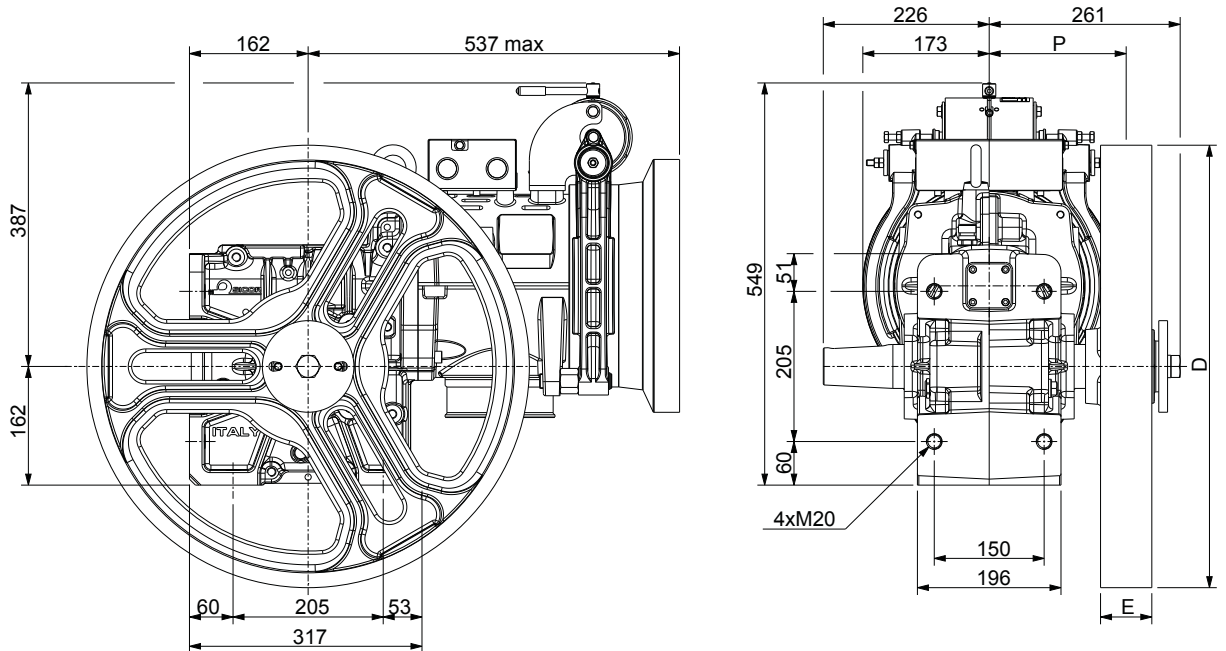

Wrapping System	Traction sheave		Dimension	Load*)	Static Load Direction
	D [mm]	E [mm]	P [mm]	F [kN - kg]	
CSW	320	76	190	20,6 - 2100	
	360				
	400				
	450	70	187		
	480				
	520				
	550				
600					

*) Max. static load on the slow shaft: CSW:Conventional single wrap

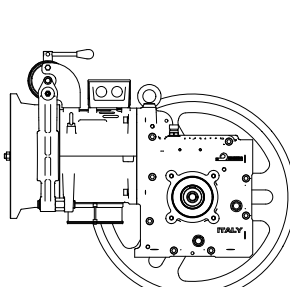

horizontal lh

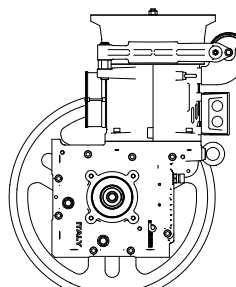

vertical

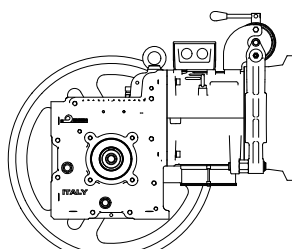

horizontal rh

Brake Electromagnet		
[V]	[A]	[W]
24	5,25	126
48	2,30	110
60	1,77	106
80	1,50	120
110	1,02	112
200	0,63	126

DUTY TABLE

Roping 1:1

		50Hz			60Hz			50Hz			60Hz	
		VVVF 1500 rpm 4 Poles AC2 1500/375 rpm 4/16 Poles			VVVF 1800 rpm 4 Poles AC2 1800/450 rpm 4/16 Poles			VVVF 1000 rpm 6 Poles AC2 1000/375 rpm 6/16 Poles			VVVF 1200 rpm 6 Poles	
		Motor Output [kW]										
		VVVF/AC2 4		VVVF 5,5	VVVF/AC2 4,4		VVVF 6	VVVF/AC2 2,7		VVVF 3,6	VVVF 4	
R.R.	Traction Sheave Ø	Speed syn.	Max Rated Load		Speed syn.	Max Rated Load		Speed syn.	Max Rated Load		Speed syn.	Max Rated Load
[i]	[mm]	[m/s]	[kg]	[kg]	[m/s]	[kg]	[kg]	[m/s]	[kg]	[kg]	[m/s]	[kg]
1/55	320	0,46	650	--	0,55	650	--	0,30	650	--	0,37	650
1/55	360	0,51	615	--	0,62	615	--	0,34	615	--	0,41	615
1/55	400	0,57	550	--	0,69	550	--	0,38	550	--	0,46	550
1/43	320	0,58	650	--	0,70	650	--	0,39	650	--	0,47	650
1/55	450	0,64	490	--	0,77	490	--	0,43	490	--	0,51	490
1/43	360	0,66	630	--	0,79	630	--	0,44	650	--	0,53	650
1/55	480	0,69	460	--	0,82	460	--	0,46	460	--	0,55	460
1/43	400	0,73	570	--	0,88	570	--	0,49	610	--	0,58	610
1/55	520	0,74	425	--	0,89	425	--	0,50	425	--	0,59	425
1/55	550	0,79	400	--	0,94	400	--	0,52	400	--	0,63	400
1/43	450	0,82	505	--	0,99	505	--	0,55	540	--	0,66	540
1/55	600	0,86	365	--	1,03	365	--	0,57	365	--	0,69	365
1/43	480	0,88	475	--	1,05	475	--	0,58	505	--	0,70	505
2/55	320	0,91	540	650	1,10	490	650	0,61	550	650	0,73	650
1/43	520	0,95	435	--	1,14	435	--	0,63	470	--	0,76	470
1/43	550	1,00	415	--	1,21	415	--	0,67	440	--	0,80	440
2/55	360	1,03	480	605	1,23	435	605	0,69	490	605	0,82	605
1/43	600	1,10	380	--	1,32	380	--	0,73	405	--	0,88	405
2/55	400	1,14	430	545	1,37	390	545	0,76	440	545	0,91	545
2/43	320	1,17	430	610	1,40	390	550	0,78	435	600	0,94	550
2/55	450	1,29	385	485	1,54	345	485	0,86	390	485	1,03	485
2/43	360	1,32	380	540	1,58	345	485	0,88	390	530	1,05	490
2/55	480	1,37	360	455	1,65	325	455	0,91	365	455	1,10	455
2/43	400	1,46	345	485	1,75	310	440	0,97	350	480	1,17	440
2/55	520	1,49	330	420	1,78	300	420	0,99	335	420	1,19	420
2/55	550	1,57	315	395	1,88	285	395	1,05	320	395	1,26	395
2/43	450	1,64	305	430	1,97	275	390	1,10	310	425	1,32	390
2/55	600	1,71	285	360	2,06	260	360	1,14	290	360	1,37	360
2/43	480	1,75	285	405	2,10	260	365	1,17	290	400	1,40	365
2/43	520	1,90	265	375	2,28	240	335	1,27	270	365	1,52	335
2/43	550	2,01	250	355	2,41	225	320	1,34	255	345	1,61	320
2/43	600	2,19	230	325	2,63	205	290	1,46	230	320	1,75	290

		50Hz			60Hz			50Hz			60Hz	
		Potenza Motore [kW]										
		VVVF/AC2 4		VVVF 5,5	VVVF/AC2 4,4		VVVF 6	VVVF/AC2 2,7		VVVF 3,6	VVVF 4	
R.R.		Max Output Torque	Geared Efficiency		Max Output Torque	Geared Efficiency		Max Output Torque	Geared Efficiency		Max Output Torque	Geared Efficiency
[i]		[Nm]			[Nm]			[Nm]			[Nm]	
1/55		680	0,72	0,74	680	0,71	0,73	680	0,72	0,74	680	0,73
1/43		700	0,74	0,76	700	0,73	0,76	750	0,74	0,76	750	0,76
2/55		670	0,80	0,82	670	0,79	0,81	670	0,80	0,82	670	0,82
2/43		700	0,81	0,84	700	0,80	0,83	740	0,82	0,84	740	0,83

Rated load values listed in the table include the weight of the ropes.

To know the theoretical load, subtract the weight of the ropes.

Position Of The Geared = Top Counterweight = 50% Plant efficiency = 0,80

		50Hz					
		VVVF 1500 rpm 4 Poles AC2 1500/375 rpm 4/16 Poles			VVVF 1000 rpm 6 Poles AC2 1000/375 rpm 6/16 Poles		
		Asynchronous Rated Power [kW]					
		VVVF 4	VVVF 5,5	AC2 4	VVVF 2,7	VVVF 3,6	AC2 2,7
		Motor Parameters					
Rated Voltage (star connection) ^{(1) (3)}	[V]	400	400	400	400	400	400
Frequency	[Hz]	50	50	50	50	50	50
Synchronous Speed	[rpm]	1500	1500	1500/375	1000	1000	1000/375
Asynchronous Speed	[rpm]	1423	1424	1359/276	955	962	893/268
Rated Current ⁽²⁾	[A]	9,4	12,4	11,3/11,1	8,4	10,9	10,9/11,5
Rated Torque	[Nm]	26,8	36,9	28,1	27	35,7	28,9
Cos ϕ Power Factor	[]	0,76	0,78	0,64	0,61	0,62	0,52
Starting Current	[A]	41	51	39	30	43	29
Starting Torque	[Nm]	54	78	79	46	80	69
Duty Cycle	[%]	60	60	30+10	60	60	30+10
Starts per Hour	[s/h]	240	240	180	240	240	180
Insulation Class	[]	F	F	F	F	F	F
Degree of Protection IP	[]	IP21	IP21	IP21	IP21	IP21	IP21

(1) The motors are standard supplied with star connection (Y), the customer can arrange a delta connection (Δ).

(2) The indicated current values are related to 400V voltage. For current values with delta connection, multiply the values by 1,732.

(3) The standard supply voltage is suitable for 380-400V/220-230V power supplies.

The geared machine includes a fan, 1~220...240V, 50/60Hz.

Available on request 115V supply voltage.

		60Hz			
		VVVF 1800 rpm 4 Poles AC2 1800/450 rpm 4/16 Poles			VVVF 1200 rpm 6 Poles
		Asynchronous Rated Power [kW]			
		VVVF 4,4	VVVF 6	AC2 4,4	VVVF 4
		Motor Parameters			
Rated Voltage (star connection) ^{(1) (3)}	[V]	400	400	400	400
Frequency	[Hz]	60	60	60	60
Synchronous Speed	[rpm]	1800	1800	1800/450	1200
Asynchronous Speed	[rpm]	1714	1708	1606/330	1138
Rated Current ⁽²⁾	[A]	10,2	15,2	11,8/10	12,4
Rated Torque	[Nm]	24,5	33,5	26,2	33,6
Cos ϕ Power Factor	[]	0,75	0,7	0,63	0,6
Starting Current	[A]	48	70	39	49
Starting Torque	[Nm]	44	70	64	62
Duty Cycle	[%]	60	60	30+10	60
Starts per Hour	[s/h]	240	240	180	240
Insulation Class	[]	F	F	F	F
Degree of Protection IP	[]	IP21	IP21	IP21	IP21

(1) The motors are standard supplied with star connection (Y), the customer can arrange a delta connection (Δ).

(2) The indicated current values are related to 400V voltage. For current values with delta connection, multiply the values by 1,732.

(3) The standard supply voltage is suitable for 380-400V/220-230V power supplies.

The geared machine includes a fan, 1~220...240V, 50/60Hz.

Available on request 115V supply voltage.

TRACTION SHEAVES AND GROOVES NUMBER x ROPES DIAMETER

Wrapping System	Traction sheave		Max n° Grooves x D	Grooves Pitch
	D [mm]	E [mm]	n° x mm	l [mm]
CSW	320	76	5xD8	14
	360	70	5xD8	14
	360	70	4xD9	17
	400	70	5xD8	14
	400	70	4xD9	17
	400	70	4xD10	17
	450	70	5xD8	14
	450	70	4xD9	17
	450	70	4xD10	17
	450	70	4xD11	17
	480	70	5xD8	14
	480	70	4xD9	17
	480	70	4xD10	17
	480	70	4xD11	17
	480	70	3xD12	19
	520	70	5xD8	14
	520	70	4xD9	17
	520	70	4xD10	17
	520	70	4xD11	17
	520	70	3xD12	19
	520	70	3xD13	19
	550	70	5xD8	14
	550	70	4xD9	17
	550	70	4xD10	17
	550	70	4xD11	17
	550	70	3xD12	19
	550	70	3xD13	19
	600	70	5xD8	14
	600	70	4xD9	17
	600	70	4xD10	17
	600	70	4xD11	17
	600	70	3xD12	19
600	70	3xD13	19	

VCI

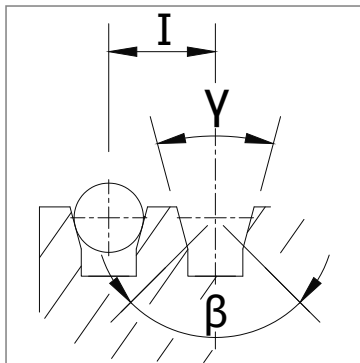

V grooves with undercut

UCI

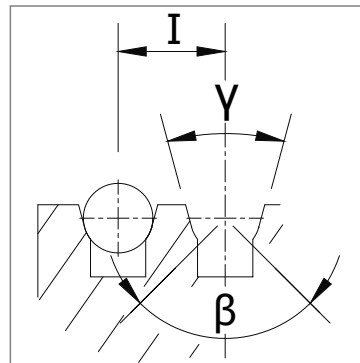

U grooves with undercut

γ = groove angle
 β = undercut angle
 I = grooves pitch

BEDPLATE | TOP MACHINE WITHOUT DIVERTING PULLEY FOR CSW WRAPPING

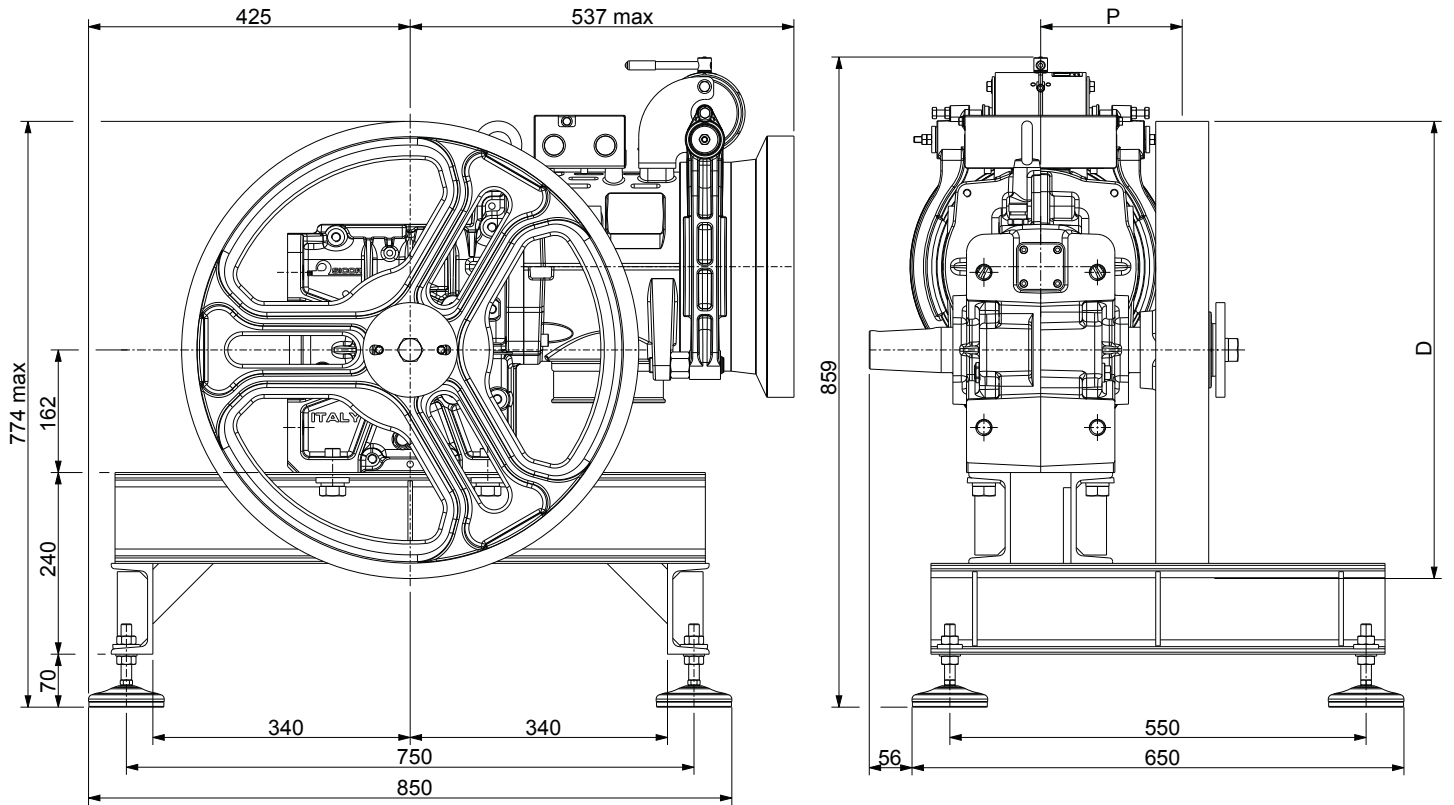

XTE0456 (included vibration dampers)
 Weight of machine bedplate: 49 kg
 (bedplate + vibration dampers)

VIBRATIONS DAMPER SET UP FOR MACHINE BEDPLATE XTE0456

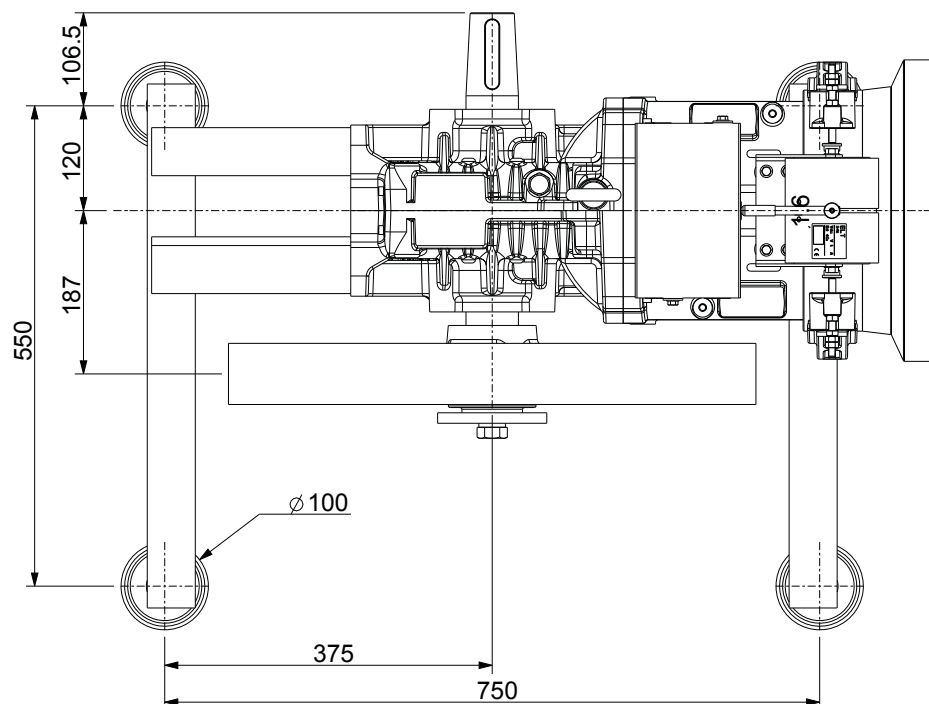

Damper code TAI0110
 Dimension [mm] D.100 x 28

BEDPLATE | TOP MACHINE WITH DIVERTING PULLEY FOR CSW WRAPPING

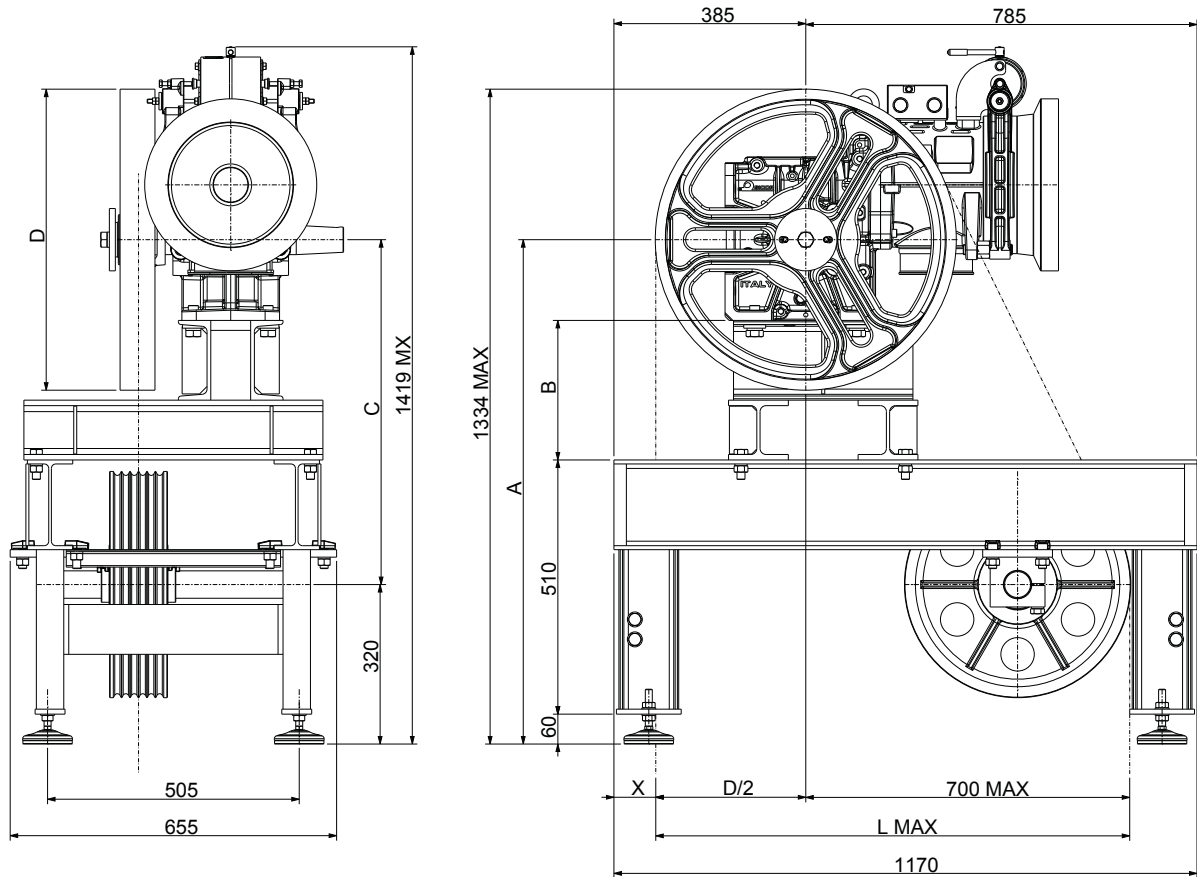

Diverting Pulley	A	B	C
Dt [mm]	[mm]	[mm]	[mm]
400	1012	280	692
450	1012	280	692
520	1032	300	712

Traction Sheave	X	L max
D [mm]	[mm]	[mm]
360	200	880
400	180	900
450	155	925
480	140	940
520	120	960
550	105	975
600	80	1000

XTE0516 (Dt 520) - XTE0517 (Dt 400-450) (included vibration dampers)

Weight of machine bedplate: (XTE0516) 163 kg,

(XTE0517) 153Kg

(bedplate + diverting pulley + vibration dampers)

VIBRATIONS DAMPER SET UP FOR MACHINE BEDPLATE XTE0516 AND XTE0517

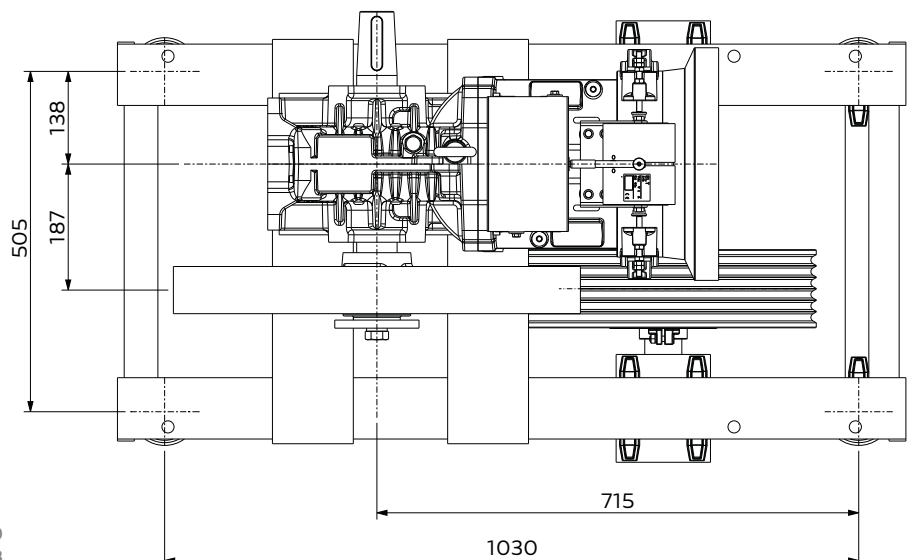

Damper code **TAI0110**
Dimension [mm] **D.100 x 28**

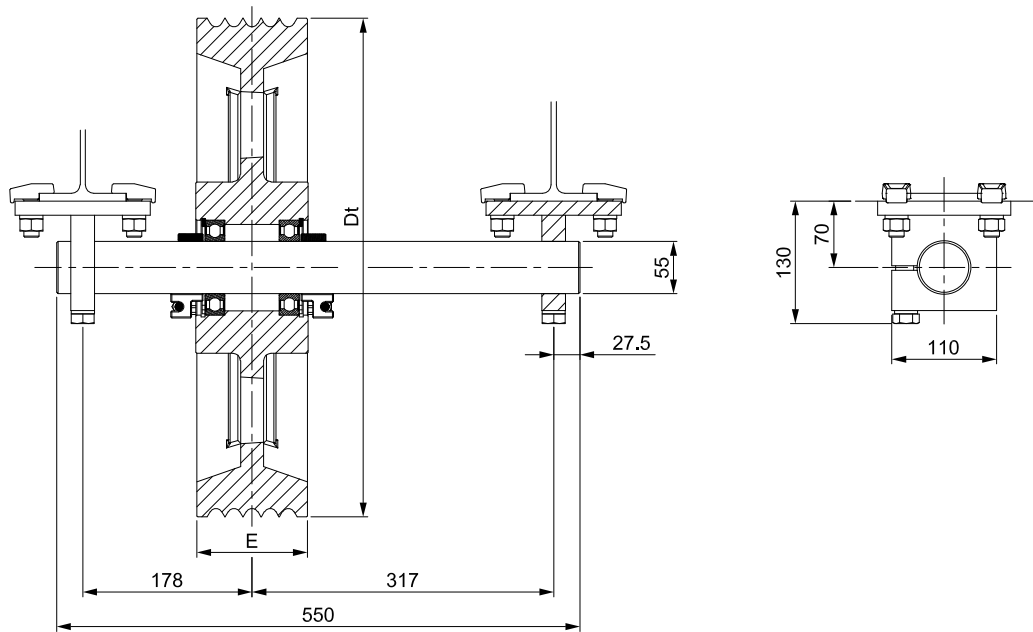

Diverting Pulley		Max n°Grooves x D	Grooves Pitch
Dt [mm]	E [mm]	n° x mm	l [mm]
400	116	7xD8	14
450	116	6xD11	17
520	116	5xD13	19



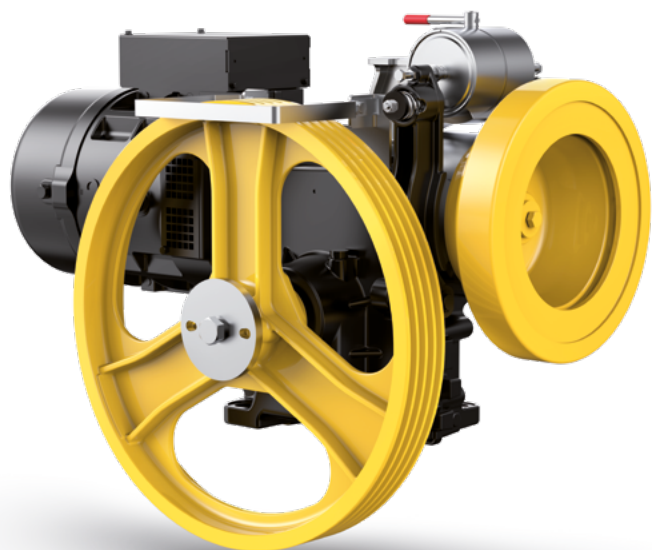

Max. Static Load	25,5 kN - 2600 kg
Power Range 50 Hz 4 poles VVVF	4 ÷ 6,7 kW
Power Range 50 Hz 4/16 poles	4 ÷ 5,5 kW
Power Range 50 Hz 6 poles VVVF	2,7 ÷ 3,6 kW
Power Range 50 Hz 6/16 poles	2,7 ÷ 3,6 kW
Power Range 60 Hz 4 poles VVVF	4,4 ÷ 6 kW
Power Range 60 Hz 4/16 poles	4,4 ÷ 6 kW
Power Range 60 Hz 6 poles VVVF	4 kW
Power Range 60 Hz 6/16 poles	4 kW
Ratio	1/55; 1/43; 2/43; 2/55
Geared Weight	240 kg
Oil capacity	3,8 l
Geared machine Rh o Lh (from motor side)	Image ref. to Rh geared

The geared machine efficiency values are present above each "rated load" table
 The motor efficiency values are present in the table "electric motor data"

DIMENSIONS

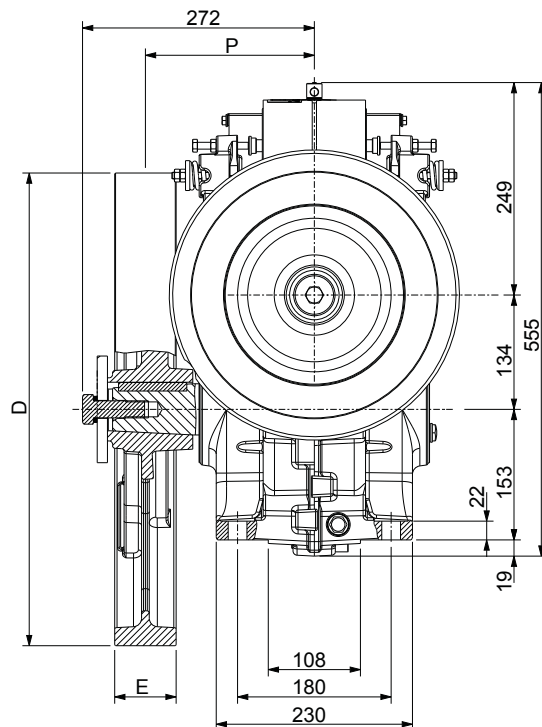
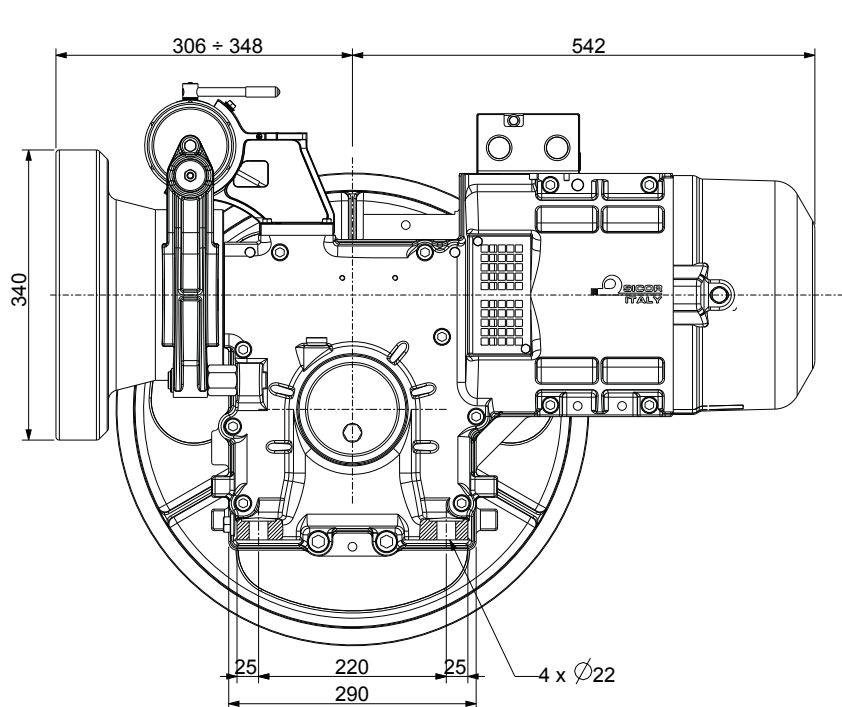

Wrapping System	Traction sheave		Dimension	Load*)	Static Load Direction	Brake Electromagnet		
	D [mm]	E [mm]	P [mm]	F [kN - kg]	[%]	[V]	[A]	[W]
ESW	340	116	210	22	↓100%	24	5,25	126
	340	76	195	25,5 - 2600	100% ← ↔ → 100% ↓ 100%	48	2,30	110
	340	100	202	24,7 - 2500		60	1,77	106
CSW	400	70	197	25,5 - 2600		80	1,50	120
	450	70	197	25,5 - 2600		110	1,02	112
	480	70	197	25,5 - 2600		200	0,63	126
	550	70	197	25,5 - 2600				
	600	68	232	17,7 - 1800				

*) Max. static load on the slow shaft:
 CSW: Conventional single wrap.
 ESW: Extended single wrap (patented).

				50Hz				60Hz		
				VVVF 1500 rpm 4 Poles AC2 1500/375 rpm 4/16 Poles				VVVF 1800 rpm 4 Poles AC2 1800/450 rpm 4/16 Poles		
				Motor Output [kW]						
Wrapping system		R.R.	Traction Sheave Ø	Speed syn.	VVVF/AC2 4	VVVF/AC2 5,5	VVVF 6,7	Speed syn.	VVVF/AC2 4,4	VVVF/AC2 6
CSW	ESW	[i]	[mm]	[m/s]	Max Rated Load [kg]			[m/s]	Max Rated Load [kg]	
X	X	1/52	340	0,51	750	--	--	0,62	750	--
X	X	1/45	340	0,59	750	--	--	0,71	705	750
X	X	1/52	400	0,60	750	--	--	0,72	675	750
X	--	1/43	340	0,62	750	--	--	0,75	675	750
X	--	1/52	450	0,68	665	695	--	0,82	600	695
X	--	1/45	400	0,70	660	750	--	0,84	600	725
X	--	1/52	480	0,72	625	650	--	0,87	565	650
X	--	1/43	400	0,73	635	750	--	0,88	575	750
X	--	1/45	450	0,79	590	710	--	0,94	535	645
X	--	1/43	450	0,82	565	705	--	0,99	510	705
X	--	1/52	550	0,83	545	570	--	1,00	490	570
X	--	1/45	480	0,84	550	665	--	1,01	500	600
X	--	1/43	480	0,88	530	660	--	1,05	480	660
X	--	1/52	600	0,91	500	520	--	1,09	450	520
X	--	1/45	550	0,96	480	580	--	1,15	435	525
X	--	1/43	550	1,00	460	580	--	1,21	415	580
X	X	2/53	340	1,01	490	700	750	1,21	445	630
X	--	1/45	600	1,05	440	530	--	1,26	400	480
X	--	1/43	600	1,10	425	530	--	1,32	380	530
X	X	2/53	400	1,19	415	595	725	1,42	375	535
X	--	2/43	340	1,24	405	575	715	1,49	365	520
X	--	2/53	450	1,33	370	530	645	1,60	335	475
X	--	2/53	480	1,42	345	495	605	1,71	315	445
X	--	2/43	400	1,46	345	490	605	1,75	310	440
X	--	2/53	550	1,63	305	430	530	1,96	275	385
X	--	2/43	450	1,64	305	435	540	1,97	275	390
X	--	2/43	480	1,75	285	410	505	2,10	260	365
X	--	2/53	600	1,78	275	395	485	2,13	250	355
X	--	2/43	550	2,01	250	355	440	2,41	225	320
X	--	2/43	600	2,19	230	325	405	2,63	205	295

				50Hz			60Hz		
				Motor Output [kW]					
		R.R.	Max Output Torque	VVVF/AC2 4	VVVF/AC2 5,5	VVVF 6,7	Max Output Torque	VVVF/AC2 4,4	VVVF/AC2 6
		[i]	[Nm]	Geared Efficiency			[Nm]	Geared Efficiency	
		1/52	963	0,73	0,76	0,77	963	0,72	0,75
		1/45	980	0,75	0,77	0,79	890	0,74	0,77
		1/43	978	0,75	0,78	0,79	978	0,74	0,77
		2/53	895	0,80	0,83	0,84	895	0,79	0,82
		2/43	856	0,82	0,84	0,86	856	0,80	0,83

Rated load values listed in the table include the weight of the ropes. To know the theoretical load, subtract the weight of the ropes.
Position Of The Geared = Top. Counterweight = 50%. Plant efficiency = 0,80

				50Hz			60Hz		
				VVVF 1000 rpm 6 Poles AC2 1000/375 rpm 6/16 Poles			VVVF 1200 rpm 6 Poles AC2 1200/450 rpm 6/16 Poles		
				Motor Output [kW]					
					VVVF/AC2 2.7	VVVF/AC2 3.6		VVVF/AC2 4	
Wrapping system		R.R.	Traction Sheave Ø	Speed syn.	Max Rated Load		Speed syn.	Max Rated Load	
CSW	ESW	[i]	[mm]	[m/s]	[kg]	[kg]	[m/s]	[kg]	
X	X	1/52	340	0,34	750	--	0,41	750	
X	X	1/45	340	0,40	750	--	0,47	750	
X	X	1/52	400	0,40	750	--	0,48	750	
X	--	1/43	340	0,41	750	--	0,50	750	
X	--	1/52	450	0,45	675	750	0,54	750	
X	--	1/45	400	0,47	670	750	0,56	750	
X	--	1/52	480	0,48	630	745	0,58	745	
X	--	1/43	400	0,49	645	750	0,58	750	
X	--	1/45	450	0,52	595	750	0,63	750	
X	--	1/43	450	0,55	575	750	0,66	725	
X	--	1/52	550	0,55	550	650	0,66	650	
X	--	1/45	480	0,56	560	730	0,67	705	
X	--	1/43	480	0,58	535	740	0,70	680	
X	--	1/52	600	0,60	505	595	0,72	595	
X	--	1/45	550	0,64	490	640	0,77	615	
X	--	1/43	550	0,67	470	645	0,80	590	
X	X	2/53	340	0,67	495	685	0,81	630	
X	--	1/45	600	0,70	445	585	0,84	565	
X	--	1/43	600	0,73	430	590	0,88	545	
X	X	2/53	400	0,79	420	580	0,95	535	
X	--	2/43	340	0,83	410	565	0,99	520	
X	--	2/53	450	0,89	375	515	1,07	475	
X	--	2/53	480	0,95	350	485	1,14	445	
X	--	2/43	400	0,97	350	480	1,17	440	
X	--	2/53	550	1,09	305	420	1,30	385	
X	--	2/43	450	1,10	310	425	1,32	390	
X	--	2/43	480	1,17	290	400	1,40	365	
X	--	2/53	600	1,19	280	385	1,42	355	
X	--	2/43	550	1,34	255	350	1,61	320	
X	--	2/43	600	1,46	230	320	1,75	295	

				50Hz			60Hz		
				Motor Output [kW]					
					VVVF/AC2 2.7	VVVF/AC2 3.6		VVVF/AC2 4	
R.R.	Max Output Torque	Geared Efficiency		Max Output Torque	Geared Efficiency				
[i]	[Nm]			[Nm]					
1/52	1102	0,73	0,75	1102	0,75				
1/45	1080	0,75	0,77	1080	0,77				
1/43	1102	0,75	0,78	1102	0,77				
2/53	1036	0,80	0,83	1036	0,82				
2/43	992	0,82	0,84	992	0,83				

		50Hz								
		VVVF 1500 rpm 4 Poles AC2 1500/375 rpm 4/16 Poles				VVVF 1000 rpm 6 Poles AC2 1000/375 rpm 6/16 Poles				
		Asynchronous Rated Power [kW]								
		VVVF 4	VVVF 5,5	VVVF 6,7	AC2 4	AC2 5,5	VVVF 2,7	VVVF 3,6	AC2 2,7	AC2 3,6
		Motor Parameters								
Rated Voltage (star connection) ^{(1) (3)}	[V]	400	400	400	400	400	400	400	400	400
Frequency	[Hz]	50	50	50	50	50	50	50	50	50
Synchronous Speed	[rpm]	1500	1500	1500	1500/375	1500/375	1000	1000	1000/375	1000/375
Asynchronous Speed	[rpm]	1379	1368	1440	1359/276	1359/280	912	920	893/268	917/270
Rated Current ⁽²⁾	[A]	10,4	15,2	16,5	12,7/11,4	15/15,5	8,8	11,5	10,9/11,5	15/12,4
Rated Torque	[Nm]	27,7	38,4	44,4	28,1	38,7	28,3	37,5	28,9	37,2
Cos ϕ Power Factor	[]	0,72	0,69	0,69	0,77	0,69	0,6	0,67	0,65	0,5
Starting Current	[A]	42	58	95	39	52	29	38	29	39
Starting Torque	[Nm]	73	114	115	79	94	77	111	69	98
Duty Cycle	[%]	40	40	40	30+10	27+10	40	40	30+10	30+10
Starts per Hour	[s/h]	240	240	240	180	180	240	240	180	180
Insulation Class	[]	F	F	F	F	F	F	F	F	F
Degree of Protection IP	[]	IP21	IP21	IP21	IP21	IP21	IP21	IP21	IP21	IP21

(1) The motors are standard supplied with star connection (Y), the customer can arrange a delta connection (Δ).

(2) The indicated current values are related to 400V voltage. For current values with delta connection, multiply the values by 1,732.

(3) The standard supply voltage is suitable for 380-400V/220-230V power supplies.

The geared machine includes a fan, 1~220...240V, 50/60Hz.

Available on request 115V supply voltage.

		60Hz					
		VVVF 1800 rpm 4 Poles AC2 1800/450 rpm 4/16 Poles			VVVF 1200 rpm 6 Poles AC2 1200/450 rpm 6/16 Poles		
		Asynchronous Rated Power [kW]					
		VVVF 4,4	VVVF 6	AC2 4,4	AC2 6	VVVF 4	AC2 4
		Motor Parameters					
Rated Voltage (star connection) ^{(1) (3)}	[V]	380	400	400	400	400	380
Frequency	[Hz]	60	60	60	60	60	60
Synchronous Speed	[rpm]	1800	1800	1800/450	1800/450	1200	1200/450
Asynchronous Speed	[rpm]	1630	1660	1606/330	1680/380	1100	1096/318
Rated Current ⁽²⁾	[A]	11	15,2	11,8/10	18/14	20	13,2/10,4
Rated Torque	[Nm]	25,8	34,5	26,2	34,1	34,7	34,8
Cos ϕ Power Factor	[]	0,81	0,81	0,63	0,78	0,67	0,58
Starting Current	[A]	42	52	39	48	42	35
Starting Torque	[Nm]	65	113	64	74	73	57
Duty Cycle	[%]	40	40	30+10	27+10	40	30+10
Starts per Hour	[s/h]	240	240	180	180	240	180
Insulation Class	[]	F	F	F	F	F	F
Degree of Protection IP	[]	IP21	IP21	IP21	IP21	IP21	IP21

(1) The motors are standard supplied with star connection (Y), the customer can arrange a delta connection (Δ).

(2) The indicated current values are related to 400V voltage. For current values with delta connection, multiply the values by 1,732.

(3) The standard supply voltage is suitable for 380-400V/220-230V power supplies.

The geared machine includes a fan, 1~220...240V, 50/60Hz.

Available on request 115V supply voltage.

TRACTION SHEAVES AND GROOVES NUMBER x ROPES DIAMETER

Winding System	Traction sheave		Max n°Grooves x D	Grooves Pitch	
	D [mm]	E [mm]	n° x mm	l [mm]	
ESW	340	116	6xD8	20	
	340	76	6xD8	12	
	340	100	8xD8	12	
	400	70	5xD8	14	
	400	70	4xD9	17	
	400	70	4xD10	17	
	450	70	5xD8	14	
	450	70	4xD9	17	
	450	70	4xD10	17	
	450	70	4xD11	17	
	480	70	4xD11	17	
	480	70	3xD12	19	
	CSW	550	70	5xD8	14
		550	70	4xD9	17
550		70	4xD10	17	
550		70	4xD11	17	
550		70	3xD12	19	
550		70	3xD13	19	
600		68	5xD8	12	
600		68	4xD9	16	
600		68	4xD10	16	
600		68	3xD11	18	
600		68	3xD12	18	
600		68	3xD13	19	

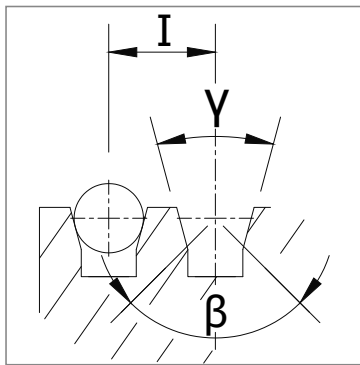
VCI

V grooves with undercut

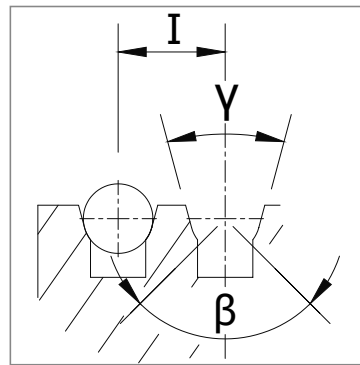
UCI

U grooves with undercut

γ = groove angle
 β = undercut angle
 I = grooves pitch

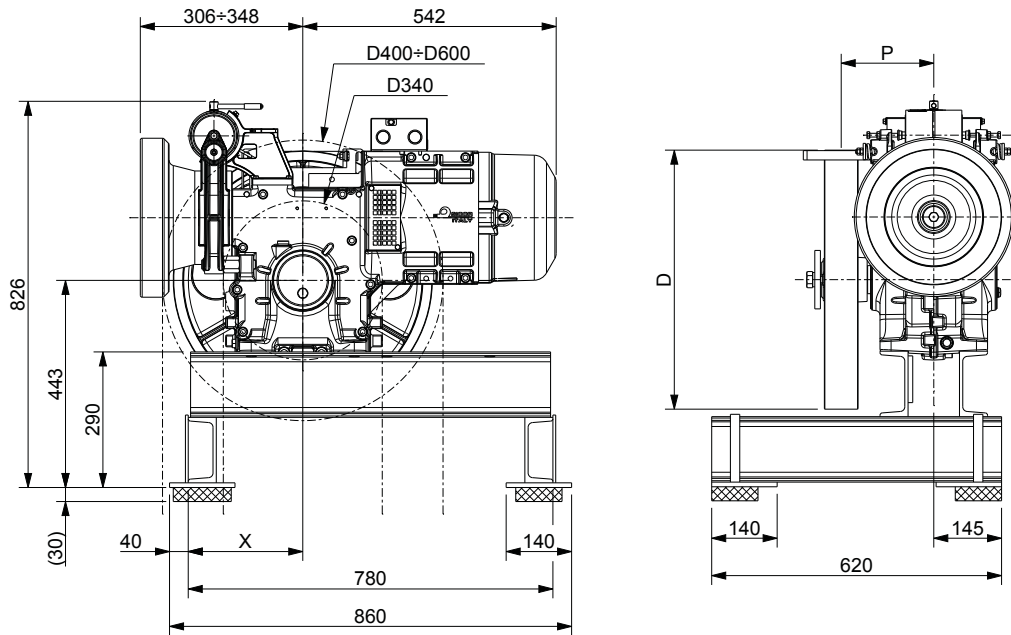

Code	Traction Sheave	P	X
	D [mm]	[mm]	[mm]
XTE0053 (included vibration dampers)	340	195	245
	340	202	245
	400	197	180
	450	197	180
	480	197	180
	550	197	245
	600	232	245

Weight of machine bedplate: 60 kg (bedplate + vibration dampers)

INSTALLATION POSITION

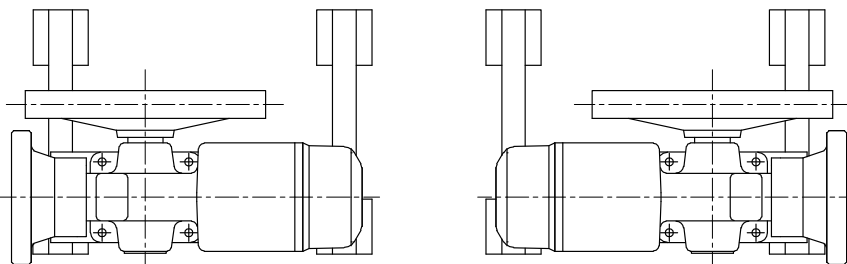

Right hand Machine

Left hand Machine

VIBRATIONS DAMPER SET UP

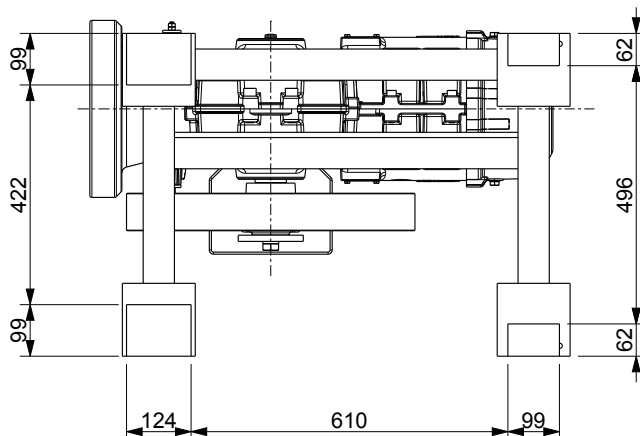

Damper code	Dimension
	[mm]
TAI0033	62x99xh30
TAI0017	99x124xh30

BEDPLATE | TOP MACHINE WITH DIVERTING PULLEY FOR CSW WRAPPING

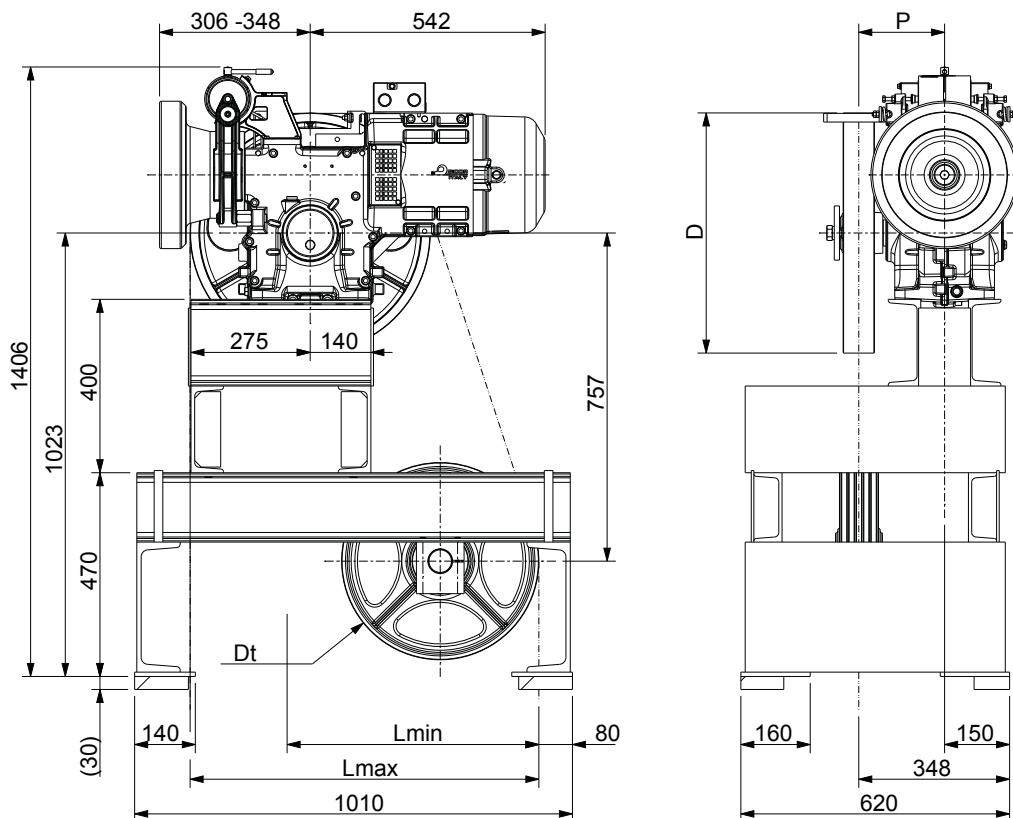

Code	Traction Sheave	P	L min	L max	Ø Div. Pulley shaft
	D [mm]	[mm]	[mm]	[mm]	[mm]
XTE0056	450	197 - 201	520	850	55
	480	202	--		
	550	197 - 204	--		
	600	232	--		

Weight of machine bedplate: 195 kg. (bedplate + diverting pulley Dt450 + vibration dampers)

INSTALLATION POSITION

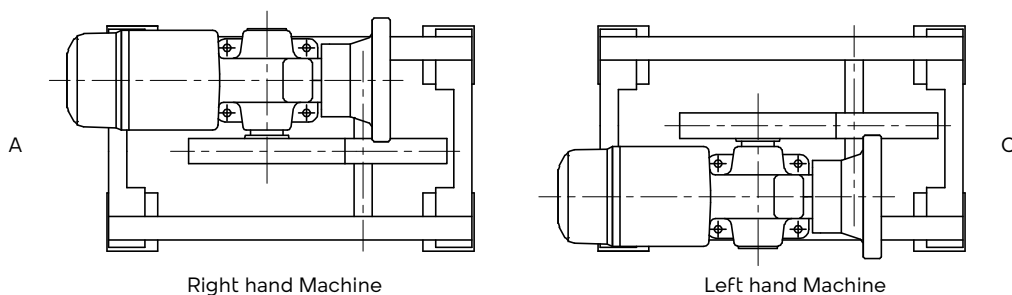

VIBRATIONS DAMPER SET UP

Damper code	Dimension
	[mm]
TAI0016	82x124xh30
TAI0017	99x124xh30

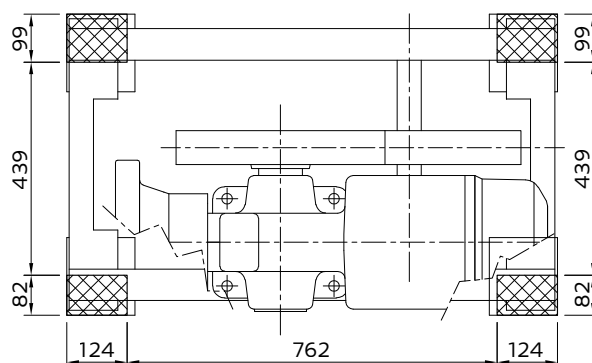

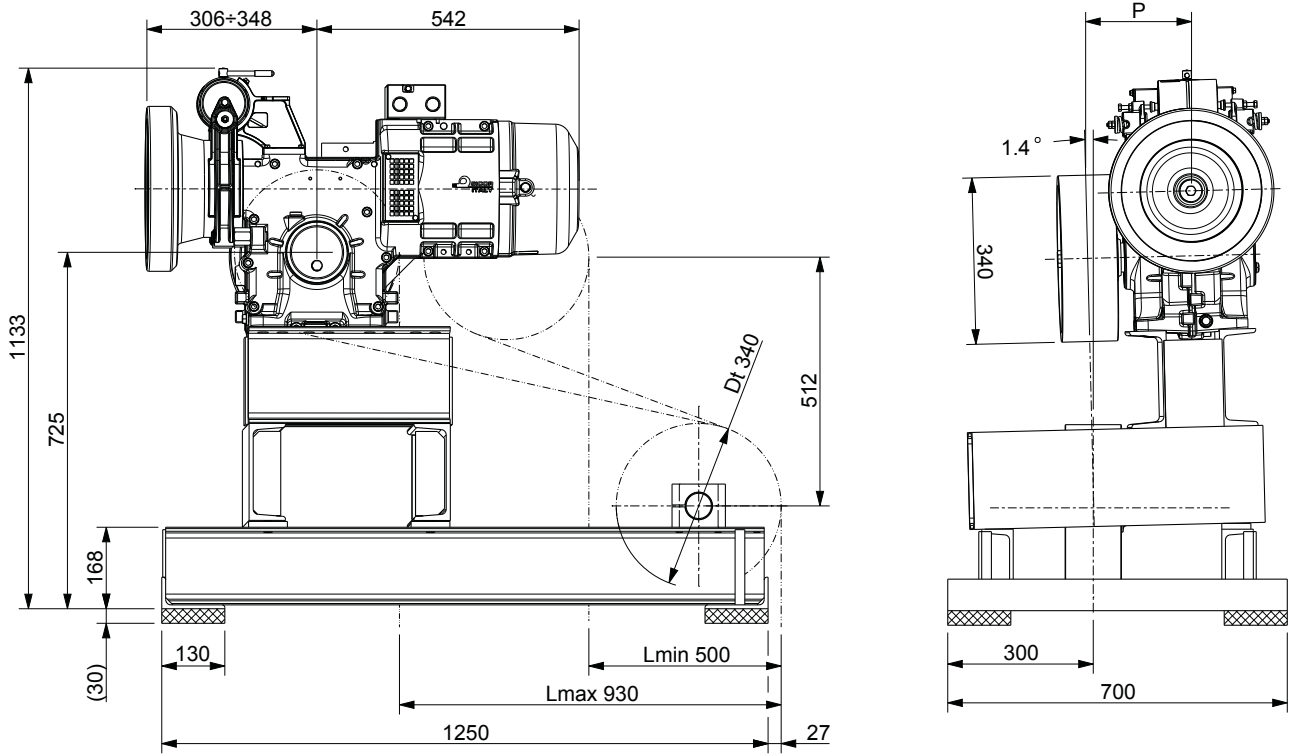

XTE0057 (included vibration dampers)
 Weight of machine bedplate: 150 kg
 (bedplate + diverting pulley Dt340 + vibration dampers)

INSTALLATION POSITION

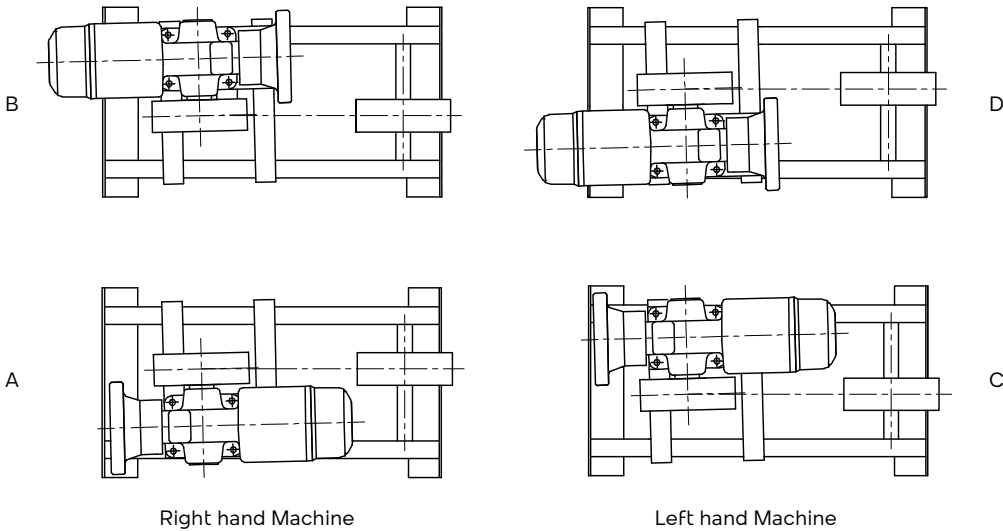

Right hand Machine

Left hand Machine

BEDPLATE | MACHINE FOR SIDE DRIVE LIFT WITH Dt 340 DIVERTING PULLEY

Roping 1:1

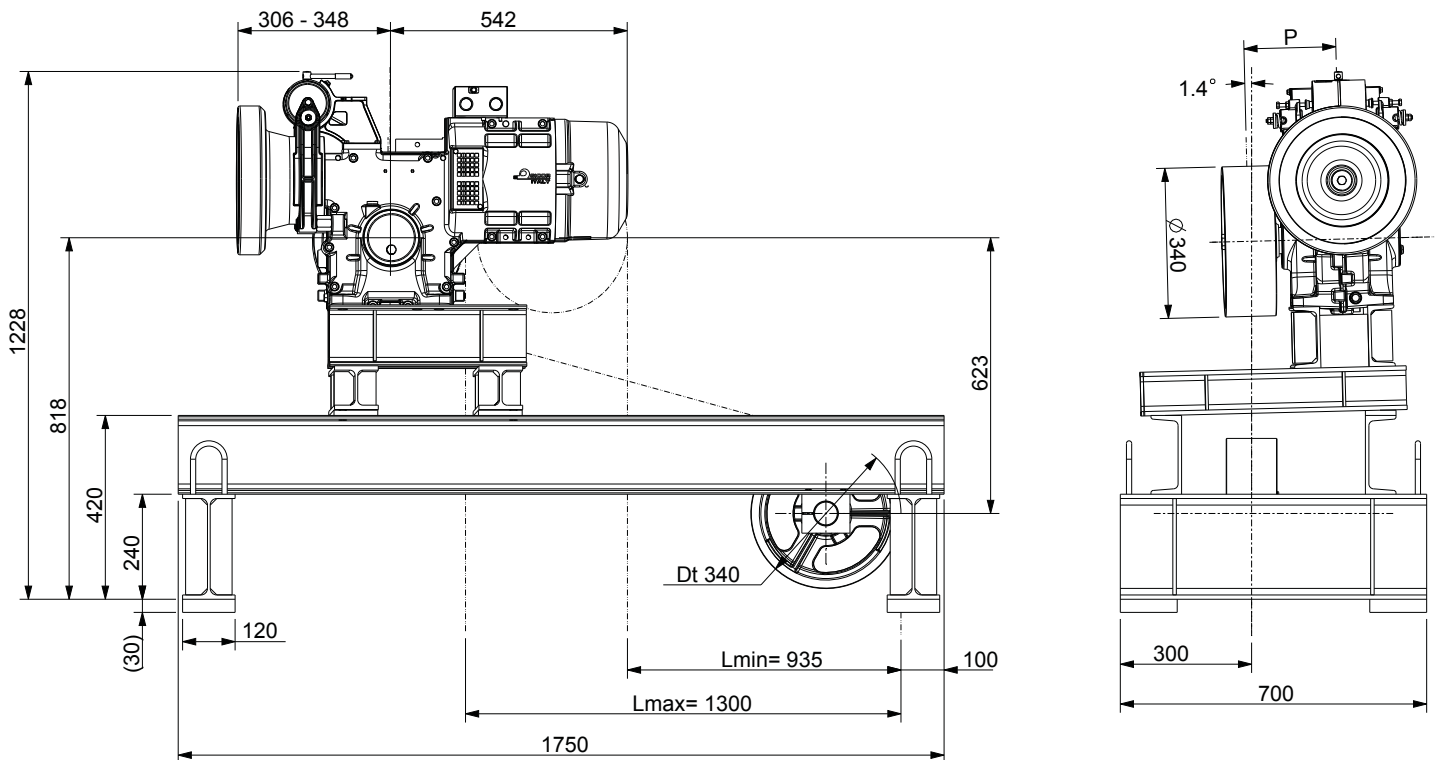

XTE0058 (included vibration dampers)
 Weight of machine bedplate: 160 kg
 (bedplate + diverting pulley Dt340 + vibration dampers)

INSTALLATION POSITION

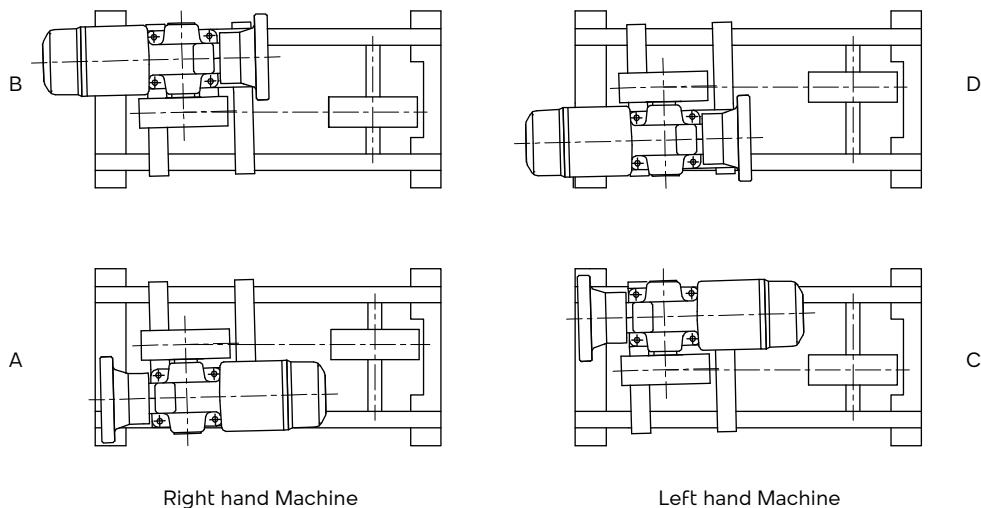

Right hand Machine

Left hand Machine

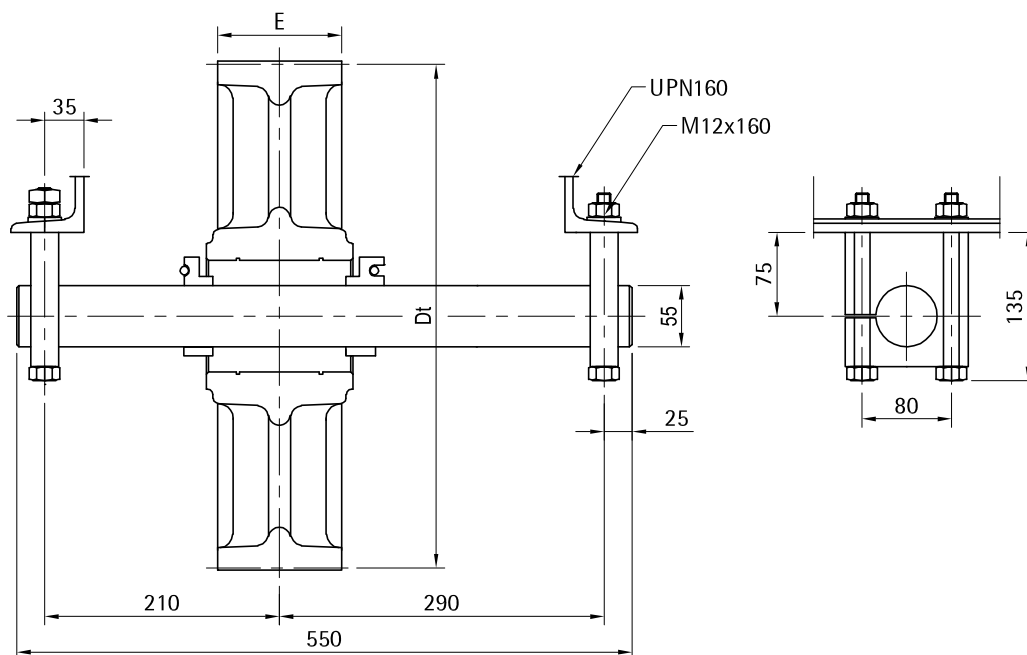

Diverting Pulley		Max n° Grooves x D	Grooves Pitch
Dt [mm]	E [mm]	n° x mm	l [mm]
340	80	6xD8	12
	120	6xD8	20
		8xD8	12/14
450	74	6xD8	12/14
	90	5xD11	17
		4xD11	17
		4xD12	19
530	90	3xD13	19

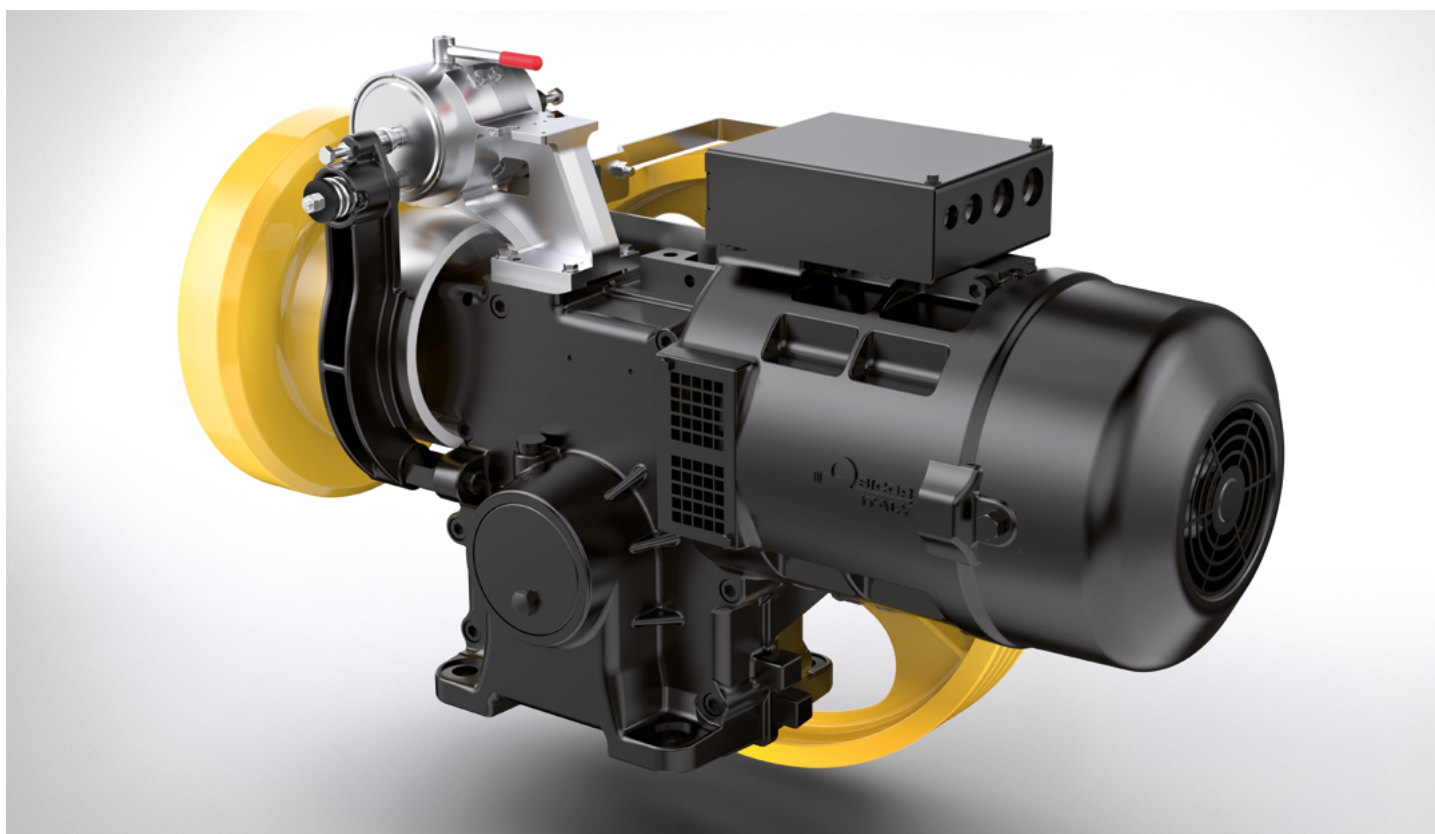

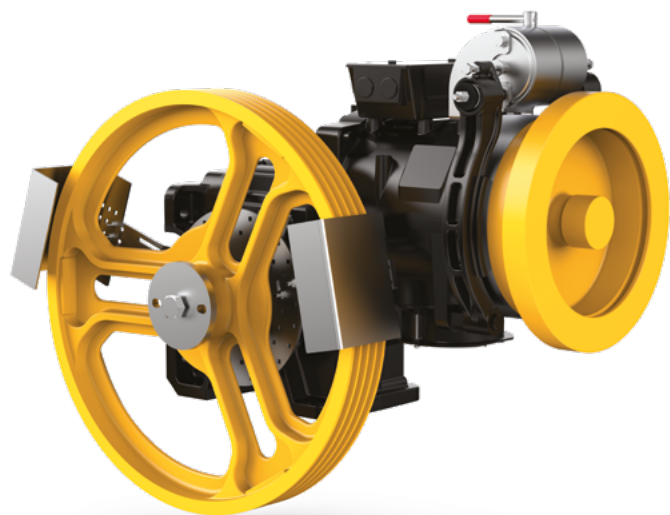

Max. Static Load **25,5 kN - 2600 kg**
 Power Range 50 Hz 4 poles VVVF **4 ÷ 7,5 kW**
 Power Range 50 Hz 4/16 poles **4 ÷ 5,5 kW**
 Power Range 50 Hz 6 poles VVVF **2,7 ÷ 4,2 kW**
 Power Range 50 Hz 6/16 poles **2,7 ÷ 3,6 kW**
 Power Range 60 Hz 4 poles VVVF **4,4 ÷ 8,2 kW**
 Power Range 60 Hz 4/16 poles **4,4 ÷ 6 kW**
 Power Range 60 Hz 6 poles VVVF **4 ÷ 4,7 kW**
 Ratio **1/52; 1/45; 1/43; 1/37; 2/43**
 Geared Weight **250 kg**
 Oil capacity **3,7 l**
 Geared machine Rh o Lh (from motor side) **Image ref. to Lh geared**

*The geared machine efficiency values are present above each "rated load" table
 The motor efficiency values are present in the table "electric motor data"*

DIMENSIONS

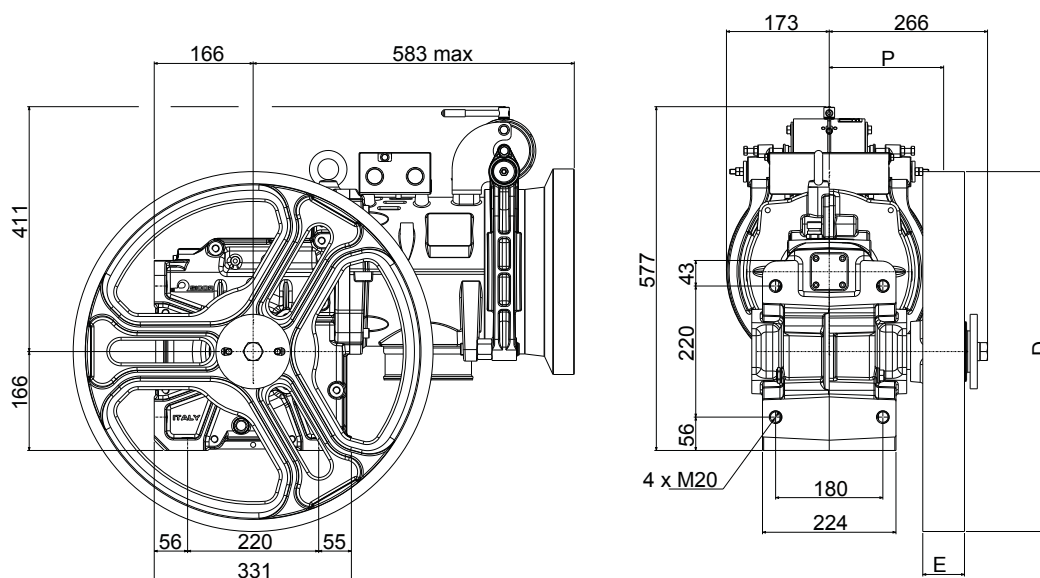

Wrapping System	Traction sheave		Dimension	Load ^{*)}	Static Load Direction
	D [mm]	E [mm]	P [mm]	F [kN - kg]	
ESW	340	116	205	22 - 2250	
	320	76	195	25,5 - 2600	
	360	70	192	25,5 - 2600	
	400				
CSW	450	70/90	192/197	25,5 - 2600/23,5 - 2400	
	480				
	520				
	550	70/90	192/197	25,5 - 2600/23,5 - 2400	
	600	70	192	25,5 - 2600	
	650				
	700				

^{*)} Max. static load on the slow shaft: CSW: Conventional single wrap. ESW : Extended single wrap (patented)

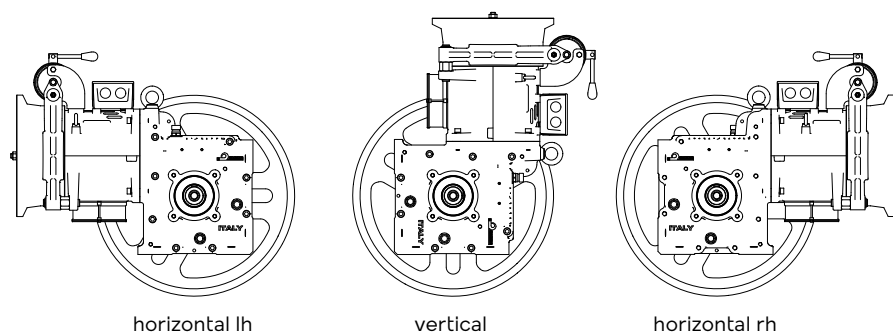

Brake Electromagnet		
[V]	[A]	[W]
24	5,25	126
48	2,30	110
60	1,77	106
80	1,50	120
110	1,02	112
200	0,63	126

		50Hz				60Hz				50Hz				60Hz		
		VVVF 1500 rpm 4 Poles AC2 1500/375 rpm 4/16 Poles				VVVF 1800 rpm 4 Poles AC2 1800/450 rpm 4/16 Poles				VVVF 1000 rpm 6 Poles AC2 1000/375 rpm 6/16 Poles				VVVF 1200 rpm 6 Poles AC2 1200/450 rpm 6/16 Poles		
		Motor Output [kW]														
			VVVF AC2 4	VVVF AC2 5,5	VVVF 7,5		VVVF AC2 4,4	VVVF AC2 6	VVVF 8,2		VVVF AC2 2,7	VVVF AC2 3,6	VVVF 4,2		VVVF AC2 4	VVVF 4,7
R.R.	Traction Sheave Ø	Speed syn.	Max Rated Load			Speed syn.	Max Rated Load			Speed syn.	Max Rated Load			Speed syn.	Max Rated Load	
[i]	[mm]	[m/s]	[kg]	[kg]	[kg]	[m/s]	[kg]	[kg]	[kg]	[m/s]	[kg]	[kg]	[kg]	[m/s]	[kg]	[kg]
1/52	320	0,48	750	--	--	0,58	750	--	--	0,32	750	--	--	0,39	750	--
1/52	360	0,54	750	--	--	0,65	750	--	--	0,36	750	--	--	0,43	750	--
1/45	320	0,56	750	--	--	0,67	750	--	--	0,37	750	--	--	0,45	750	--
1/43	320	0,58	750	--	--	0,70	720	750	--	0,39	750	--	--	0,47	750	--
1/52	400	0,60	750	--	--	0,72	680	750	--	0,40	750	--	--	0,48	750	--
1/45	360	0,63	740	750	--	0,75	670	750	--	0,42	750	--	--	0,50	750	--
1/43	360	0,66	710	750	--	0,79	640	750	--	0,44	720	750	--	0,53	750	--
1/37	320	0,68	695	750	--	0,82	630	750	--	0,45	710	750	--	0,54	750	--
1/52	450	0,68	670	715	--	0,82	605	695	--	0,45	675	750	--	0,54	750	--
1/45	400	0,70	665	750	--	0,84	600	725	--	0,47	675	750	--	0,56	750	--
1/52	480	0,72	625	670	--	0,87	565	650	--	0,48	635	750	--	0,58	740	--
1/43	400	0,73	635	750	--	0,88	575	725	--	0,49	645	750	--	0,58	750	--
1/37	360	0,76	620	750	--	0,92	560	750	--	0,51	630	750	--	0,61	750	--
1/52	520	0,79	580	620	--	0,94	535	645	--	0,52	585	695	--	0,63	680	--
1/45	450	0,79	590	710	--	0,94	520	600	--	0,52	600	750	--	0,63	750	--
1/43	450	0,82	565	710	--	0,99	510	645	--	0,55	575	750	--	0,66	725	750
1/52	550	0,83	545	585	--	1,00	495	565	--	0,55	555	655	--	0,66	645	--
1/45	480	0,84	555	665	--	1,01	500	600	--	0,56	560	750	--	0,67	710	730
1/37	400	0,85	555	750	--	1,02	500	705	--	0,57	565	750	--	0,68	715	750
1/43	480	0,88	530	665	--	1,05	480	600	--	0,58	540	745	750	0,70	680	730
1/52	600	0,91	500	535	--	1,09	450	520	--	0,60	505	600	--	0,72	590	--
1/45	520	0,91	510	610	--	1,09	465	555	--	0,61	515	700	--	0,73	655	675
2/53	320	0,95	520	740	750	1,14	470	670	750	0,63	525	725	750	0,76	665	750
1/43	520	0,95	490	610	--	1,14	440	555	--	0,63	495	685	700	0,76	630	675
1/37	450	0,96	495	695	--	1,15	445	630	--	0,64	505	695	750	0,76	635	750
1/45	550	0,96	480	580	--	1,15	435	525	--	0,64	490	660	--	0,77	620	640
1/52	650	0,98	460	495	--	1,18	415	480	--	0,65	470	555	--	0,79	545	--
1/43	550	1,00	465	580	--	1,21	420	525	--	0,67	470	650	660	0,80	595	640
1/37	480	1,02	465	650	--	1,22	420	590	--	0,68	470	650	745	0,82	595	715
1/45	600	1,05	440	530	--	1,26	400	480	--	0,70	450	605	--	0,84	565	585
1/52	700	1,06	430	460	--	1,27	385	445	--	0,70	435	515	--	0,85	505	--
2/53	360	1,07	460	660	750	1,28	420	595	750	0,71	470	645	750	0,85	590	705
1/43	600	1,10	425	530	--	1,32	385	480	--	0,73	430	595	605	0,88	545	585
1/37	520	1,10	430	600	--	1,32	385	545	--	0,74	435	600	690	0,88	550	660
1/45	650	1,13	410	490	--	1,36	370	445	--	0,76	415	560	--	0,91	525	540
1/37	550	1,17	405	565	--	1,40	365	515	--	0,78	410	570	650	0,93	520	620
2/43	320	1,17	430	610	750	1,40	390	550	750	0,78	435	600	710	0,94	550	655
2/53	400	1,19	415	595	750	1,42	375	535	730	0,79	420	580	685	0,95	530	635
1/43	650	1,19	390	490	--	1,42	355	445	--	0,79	395	550	560	0,95	500	540
1/45	700	1,22	380	455	--	1,47	345	410	--	0,81	385	520	--	0,98	485	500
1/37	600	1,27	370	520	--	1,53	335	470	--	0,85	375	520	595	1,02	475	570
1/43	700	1,28	365	455	--	1,53	330	410	--	0,85	370	510	520	1,02	465	500
2/43	360	1,32	380	545	750	1,58	345	490	690	0,88	385	530	630	1,05	490	585
2/53	450	1,33	370	525	710	1,60	335	475	650	0,89	375	515	610	1,07	475	565

CONTINUED ON NEXT PAGE →

		50Hz				60Hz				50Hz				60Hz		
		VVVF 1500 rpm 4 Poles AC2 1500/375 rpm 4/16 Poles				VVVF 1800 rpm 4 Poles AC2 1800/450 rpm 4/16 Poles				VVVF 1000 rpm 6 Poles AC2 1000/375 rpm 6/16 Poles				VVVF 1200 rpm 6 Poles AC2 1200/450 rpm 6/16 Poles		
		Motor Output [kW]														
		VVVF AC2 4	VVVF AC2 5,5	VVVF 7,5		VVVF AC2 4,4	VVVF AC2 6	VVVF 8,2		VVVF AC2 2,7	VVVF AC2 3,6	VVVF 4,2		VVVF AC2 4	VVVF 4,7	
R.R.	Traction Sheave Ø	Speed syn.	Max Rated Load			Speed syn.	Max Rated Load			Speed syn.	Max Rated Load			Speed syn.	Max Rated Load	
[i]	[mm]	[m/s]	[kg]	[kg]	[kg]	[m/s]	[kg]	[kg]	[kg]	[m/s]	[kg]	[kg]	[kg]	[m/s]	[kg]	[kg]
1/37	650	1,38	340	480	--	1,66	310	435	--	0,92	350	480	550	1,10	440	525
2/53	480	1,42	345	495	665	1,71	315	445	610	0,95	350	485	570	1,14	445	530
2/43	400	1,46	340	490	685	1,75	310	440	620	0,97	345	480	565	1,17	440	525
1/37	700	1,49	315	445	--	1,78	285	405	--	0,99	325	445	510	1,19	410	490
2/53	520	1,54	320	455	610	1,85	290	410	560	1,03	325	445	530	1,23	410	490
3/47	320	1,60	315	455	635	1,93	290	410	575	1,07	320	445	525	1,28	405	485
2/53	550	1,63	300	430	580	1,96	275	390	530	1,09	305	420	500	1,30	385	460
2/43	450	1,64	305	435	610	1,97	275	390	550	1,10	310	425	505	1,32	390	465
2/43	480	1,75	285	405	570	2,10	260	365	515	1,17	290	400	470	1,40	365	435
2/53	600	1,78	275	395	530	2,13	250	355	485	1,19	280	385	455	1,42	355	425
3/47	360	1,80	280	405	565	2,17	255	365	510	1,20	285	395	470	1,44	360	435
2/43	520	1,90	260	375	525	2,28	240	340	475	1,27	265	370	435	1,52	335	405
2/53	650	1,93	255	365	490	2,31	230	330	450	1,28	260	355	420	1,54	325	390
3/47	400	2,01	255	360	510	2,41	230	325	460	1,34	255	355	420	1,60	325	390
2/43	550	2,01	250	355	495	2,41	225	320	450	1,34	250	345	410	1,61	320	380
2/53	700	2,07	235	340	455	2,49	215	305	415	1,38	240	330	390	1,66	305	360
2/43	600	2,19	225	325	455	2,63	205	295	410	1,46	230	320	375	1,75	290	350
3/47	450	2,26	225	320	450	2,71	205	290	410	1,50	230	315	375	1,80	290	345
2/43	650	2,37	210	300	420	2,85	190	270	380	1,58	210	295	350	1,90	270	320
3/47	480	2,41	210	300	425	2,89	190	270	385	1,60	215	295	350	1,93	270	325
2/43	700	2,56	195	280	390	3,07	175	250	355	1,70	195	270	325	2,05	250	300
3/47	520	2,61	195	280	390	3,13	175	250	355	1,74	195	275	325	2,09	250	300
3/47	550	2,76	185	265	370	3,31	165	235	335	1,84	185	260	305	2,21	235	280
3/47	600	3,01	170	240	340	3,61	150	215	305	2,01	170	235	280	2,41	215	260
3/47	650	3,26	155	220	310	3,91	140	200	280	2,17	155	220	260	2,61	200	240
3/47	700	3,51	145	205	290	4,21	130	185	260	2,34	145	200	240	2,81	185	220

		50Hz				60Hz				50Hz				60Hz		
		Motor Output [kW]														
		VVVF AC2 4	VVVF AC2 5,5	VVVF 7,5		VVVF AC2 4,4	VVVF AC2 6	VVVF 8,2		VVVF AC2 2,7	VVVF AC2 3,6	VVVF 4,2		VVVF AC2 4	VVVF 4,7	
R.R.	Max Output Torque	Geared Efficiency			Max Output Torque	Geared Efficiency			Max Output Torque	Geared Efficiency			Max Output Torque	Geared Efficiency		
[i]	[Nm]				[Nm]				[Nm]				[Nm]			
1/52	990	0,73	0,76	0,78	960	0,72	0,75	0,77	1110	0,73	0,76	0,77	1090	0,75	0,76	
1/45	980	0,75	0,78	0,80	890	0,74	0,77	0,79	1120	0,75	0,78	0,79	1080	0,77	0,78	
1/43	980	0,75	0,78	0,80	890	0,74	0,77	0,80	1120	0,75	0,78	0,79	1080	0,77	0,78	
1/37	960	0,76	0,79	0,82	870	0,75	0,78	0,81	1100	0,77	0,79	0,81	1060	0,79	0,80	
2/53	980	0,80	0,83	0,85	900	0,79	0,82	0,84	1060	0,80	0,82	0,84	1090	0,82	0,83	
2/43	960	0,81	0,84	0,86	880	0,80	0,83	0,86	1100	0,81	0,84	0,85	1070	0,83	0,84	
3/47	960	0,83	0,86	0,88	870	0,82	0,85	0,87	1100	0,83	0,86	0,87	1060	0,85	0,86	

Rated load values listed in the table include the weight of the ropes.

To know the theoretical load, subtract the weight of the ropes.

Position Of The Geared = Top Counterweight = 50% Plant efficiency = 0,80

		50Hz									
		VVVF 1500 rpm 4 Poles AC2 1500/375 rpm 4/16 Poles					VVVF 1000 rpm 6 Poles AC2 1000/375 rpm 6/16 Poles				
		Asynchronous Rated Power [kW]									
		VVVF 4	VVVF 5,5	VVVF 7,5	AC2 4	AC2 5,5	VVVF 2,7	VVVF 3,6	VVVF 4,2	AC2 2,7	AC2 3,6
		Motor Parameters									
Rated Voltage (star connection) ^{(1) (3)}	[V]	400	400	400	400	400	400	400	400	400	400
Frequency	[Hz]	50	50	50	50	50	50	50	50	50	50
Synchronous Speed	[rpm]	1500	1500	1500	1500/375	1500/375	1000	1000	1000	1000/375	1000/375
Asynchronous Speed	[rpm]	1423	1424	1450	1359/276	1359/280	955	962	974	893/268	917/270
Rated Current ⁽²⁾	[A]	9,4	12,4	17,8	11,3/11,1	15/15,5	8,4	10,9	14,1	10,9/11,5	15/12,4
Rated Torque	[Nm]	26,8	36,9	49,4	28,1	38,7	27	35,7	41,2	28,9	37,2
Cos φ Power Factor	[]	0,76	0,78	0,72	0,64	0,69	0,61	0,62	0,54	0,52	0,5
Starting Current	[A]	41	51	95	39	52	30	43	63	29	39
Starting Torque	[Nm]	54	78	120	79	94	46	80	100	69	98
Duty Cycle	[%]	60	60	60	30+10	30+10	60	60	60	30+10	30+10
Starts per Hour	[s/h]	240	240	240	180	180	240	240	240	180	180
Insulation Class	[]	F	F	F	F	F	F	F	F	F	F
Degree of Protection IP	[]	IP21	IP21	IP21	IP21	IP21	IP21	IP21	IP21	IP21	IP21

(1) The motors are standard supplied with star connection (Y), the customer can arrange a delta connection (Δ).

(2) The indicated current values are related to 400V voltage. For current values with delta connection, multiply the values by 1,732.

(3) The standard supply voltage is suitable for 380-400V/220-230V power supplies.

The geared machine includes a fan, 1~220...240V, 50/60Hz.

Available on request 115V supply voltage.

		60Hz								
		VVVF 1800 rpm 4 Poles AC2 1800/450 rpm 4/16 Poles					VVVF 1200 rpm 6 Poles AC2 1200/450 rpm 6/16 Poles			
		Asynchronous Rated Power [kW]								
		VVVF 4,4	VVVF 6	VVVF 8,2	AC2 4,4	AC2 6	VVVF 4	VVVF 4,7	AC2 4	
		Motor Parameters								
Rated Voltage (star connection) ^{(1) (3)}	[V]	400	400	400	400	400	400	400	400	
Frequency	[Hz]	60	60	60	60	60	60	60	60	
Synchronous Speed	[rpm]	1800	1800	1800	1800/450	1800/450	1200	1200	1200/450	
Asynchronous Speed	[rpm]	1714	1708	1741	1606/330	1680/380	1138	1160	1096/318	
Rated Current ⁽²⁾	[A]	10,2	15,2	19	11,8/10	18/14	12,4	15,4	18,7/14,3	
Rated Torque	[Nm]	24,5	33,5	45	26,2	34,1	33,6	38,7	34,8	
Cos φ Power Factor	[]	0,75	0,7	0,72	0,63	0,78	0,6	0,55	0,58	
Starting Current	[A]	48	70	88	39	46	49	67	--	
Starting Torque	[Nm]	44	70	101	64	73	62	74	--	
Duty Cycle	[%]	60	60	60	30+10	30+10	60	60	30+10	
Starts per Hour	[s/h]	240	240	240	180	180	240	240	180	
Insulation Class	[]	F	F	F	F	F	F	F	F	
Degree of Protection IP	[]	IP21	IP21	IP21	IP21	IP21	IP21	IP21	IP21	

(1) The motors are standard supplied with star connection (Y), the customer can arrange a delta connection (Δ).

(2) The indicated current values are related to 400V voltage. For current values with delta connection, multiply the values by 1,732.

(3) The standard supply voltage is suitable for 380-400V/220-230V power supplies.

The geared machine includes a fan, 1~220...240V, 50/60Hz.

Available on request 115V supply voltage.

TRACTION SHEAVES AND GROOVES NUMBER x ROPES DIAMETER

Wrapping System	Traction sheave		Max n° Grooves x D	Grooves Pitch
	D [mm]	E [mm]	n° x mm	l [mm]
CSW	320	76	5xD8	14
	340	116	6xD8	20
	360	70	5xD8	14
	360	70	4xD9	17
	400	70	5xD8	14
	400	70	4xD9	17
	400	70	4xD10	17
	450	70	5xD8	14
	450	70	4xD9	17
	450	70	4xD10	17
	450	70	4xD11	17
	480	70/90	5xD8/6xD8	14
	480	70/90	4xD9/5xD9	17
	480	70/90	4xD10/5xD10	17
	480	70/90	4xD11/5xD11	17
	480	70/90	3xD12/4xD12	19
	520	70/90	5xD8/6xD8	14
	520	70/90	4xD9/5xD9	17
	520	70/90	4xD10/5xD10	17
	520	70/90	4xD11/5xD11	17
	520	70/90	3xD12/4xD12	19
	520	70/90	3xD13/4xD13	19
	550	70/90	5xD8/6xD8	14
	550	70/90	4xD9/5xD9	17
	550	70/90	4xD10/5xD10	17
	550	70/90	4xD11/5xD11	17
	550	70/90	3xD12/4xD12	19
	550	70/90	3xD13/4xD13	19
	600	70	5xD8	14
	600	70	4xD9	17
	600	70	4xD10	17
	600	70	4xD11	17
	600	70	3xD12	19
	600	70	3xD13	19
	650	70	5xD8	14
	650	70	4xD9	17
	650	70	4xD10	17
	650	70	4xD11	17
	650	70	3xD12	19
	650	70	3xD13	19
	700	70	5xD8	14
	700	70	4xD9	17
700	70	4xD10	17	
700	70	4xD11	17	
700	70	3xD12	19	
700	70	3xD13	19	

VCI

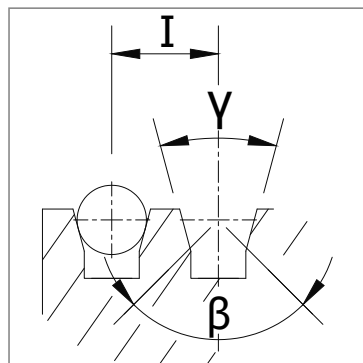

V grooves with undercut

UCI

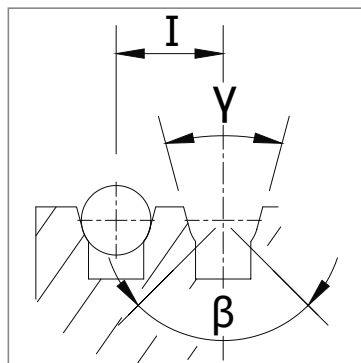

U grooves with undercut

γ = groove angle
 β = undercut angle
 I = grooves pitch

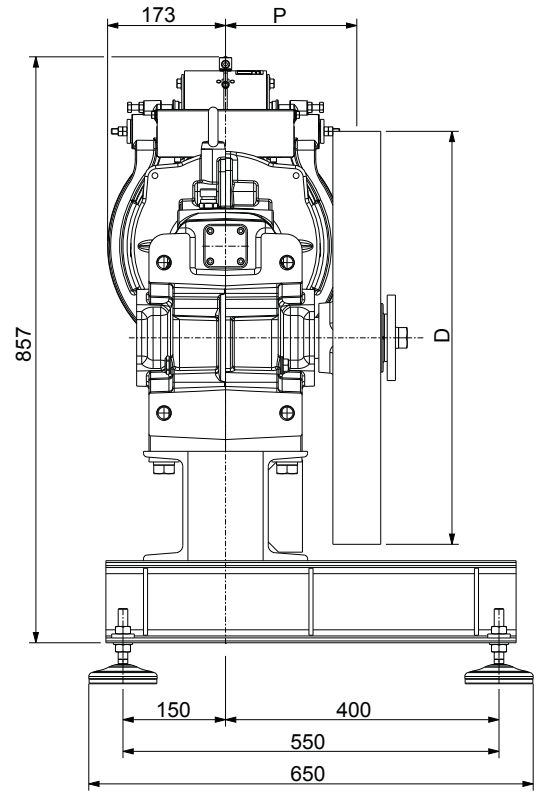
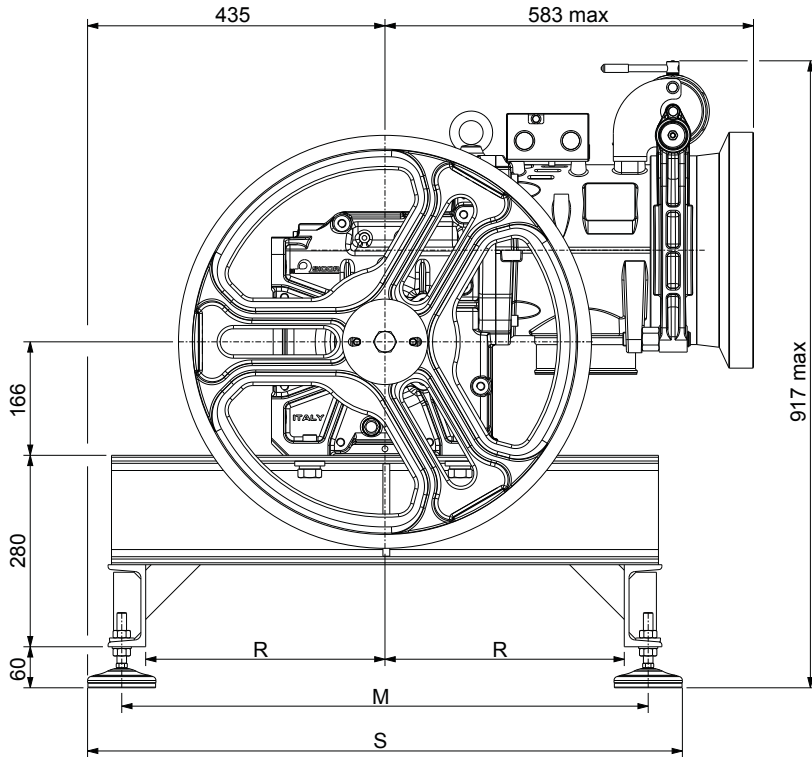

Code	M [mm]	R [mm]	S [mm]
XTE3020	770	350	870
XTE3021	540	235	640

XTE3020 (D 320-600) - **XTE3021** (D 650-700) (included vibration dampers)
 Weight of machine bedplate: (XTE3020) 53 kg, (XTE3021) 48Kg (bedplate + vibration dampers)

VIBRATIONS DAMPER SET UP

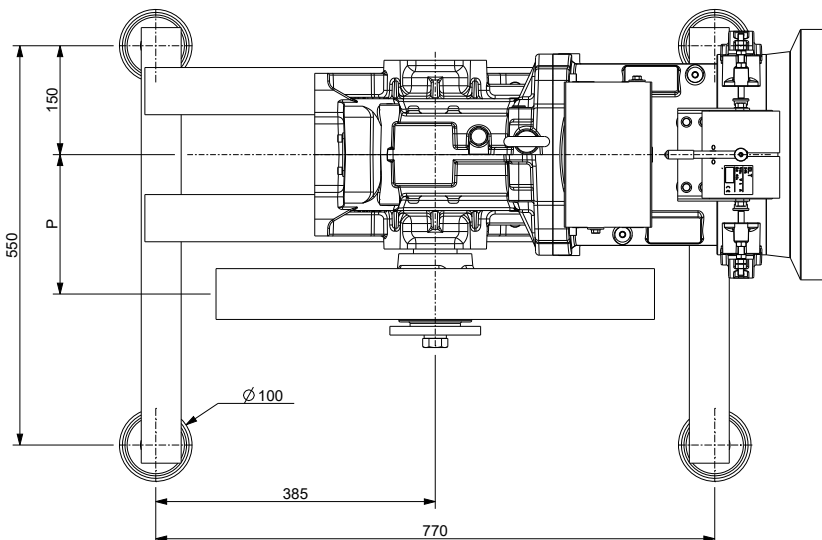

Damper code	Dimension [mm]
TAI0110	D.100x28

BEDPLATE | TOP MACHINE WITH DIVERTING PULLEY FOR CSW WRAPPING

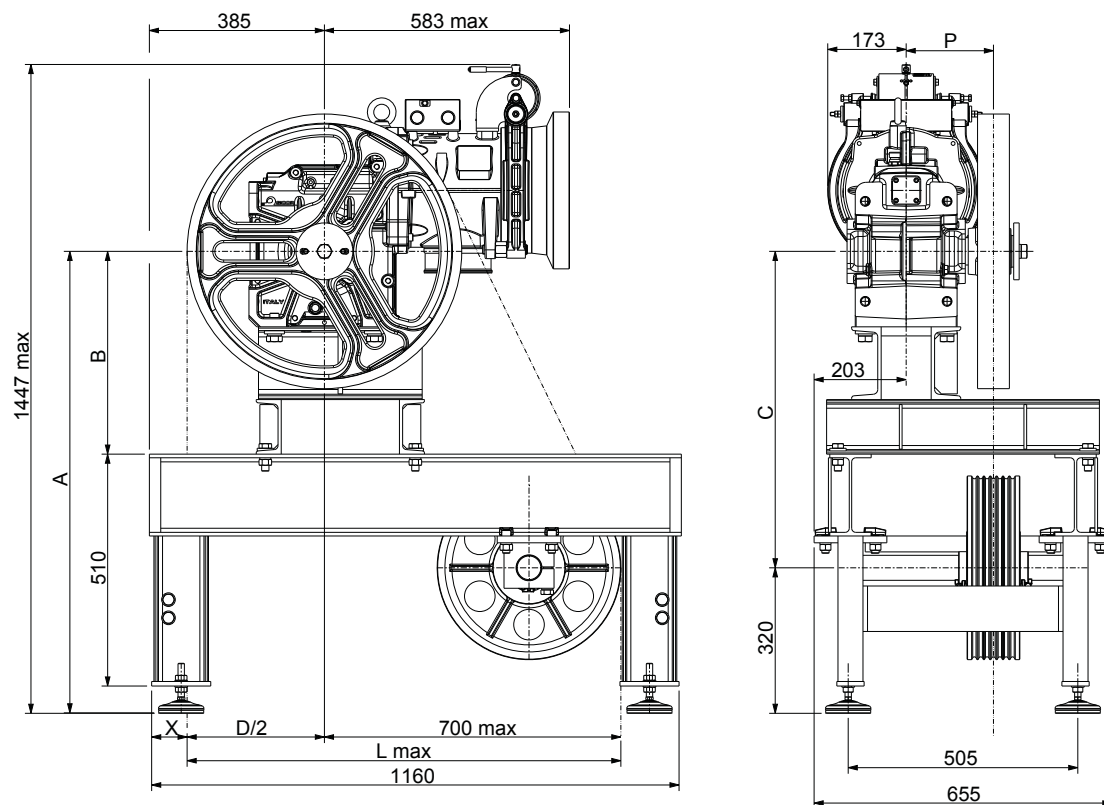

Traction Sheave	X	L max
D [mm]	[mm]	[mm]
360	200	880
400	180	900
450	155	925
480	140	940
520	120	960
550	105	975
600	80	1000

Diverting Pulley	A	B	C
Dt [mm]	[mm]	[mm]	[mm]
400	1016	280	696
450	1016	280	696
520	1036	300	716

XTE3022 (Dt 400-450) - XTE3023 (Dt 520) (included vibration dampers)

Weight of machine bedplate: (XTE3022) 138 kg, (XTE3023) 148 kg (bedplate + diverting pulley + vibration dampers)

VIBRATIONS DAMPER SET UP

Damper code	Dimension
	[mm]
TAI0110	D.100x28

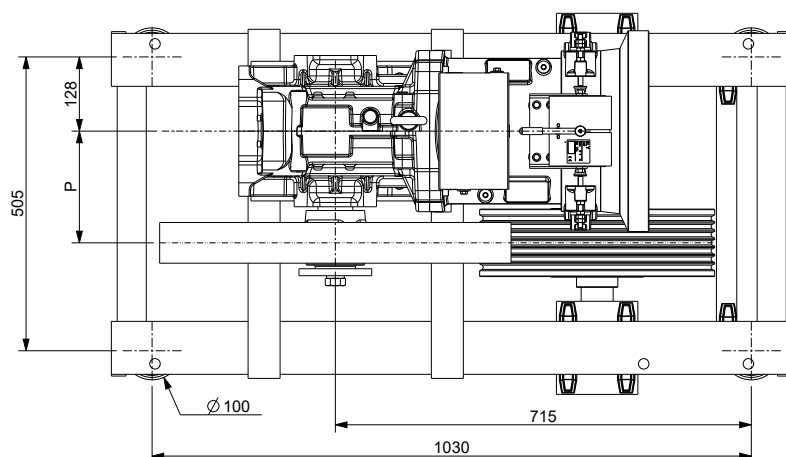

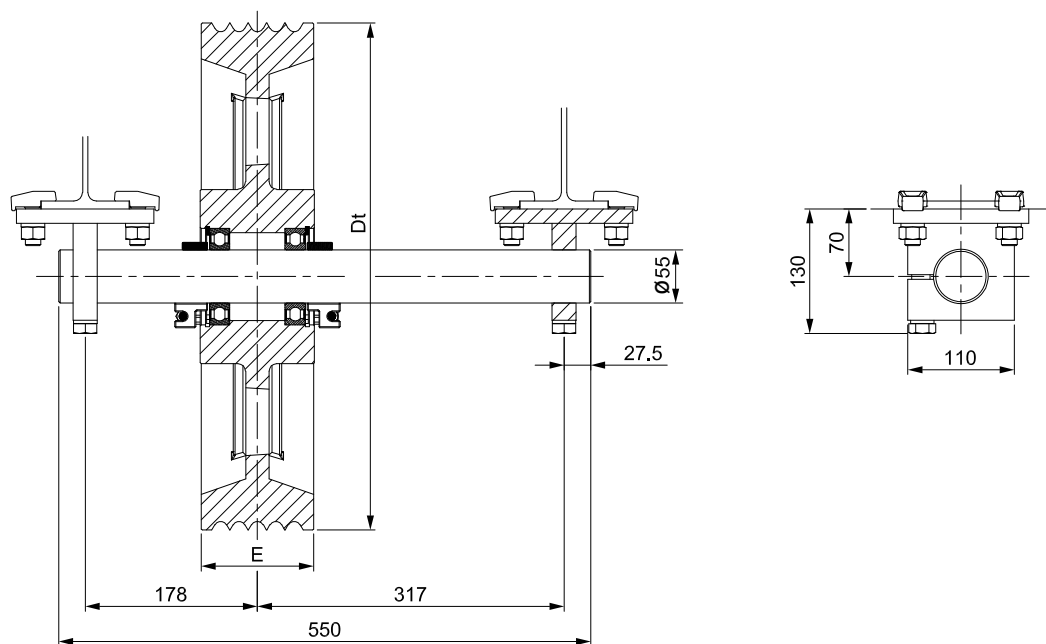

Diverting Pulley		Max n°Grooves x D	Grooves Pitch
Dt [mm]	E [mm]	n° x mm	l [mm]
400	116	7xD8	14
450	116	6xD11	17
520	116	5xD13	19

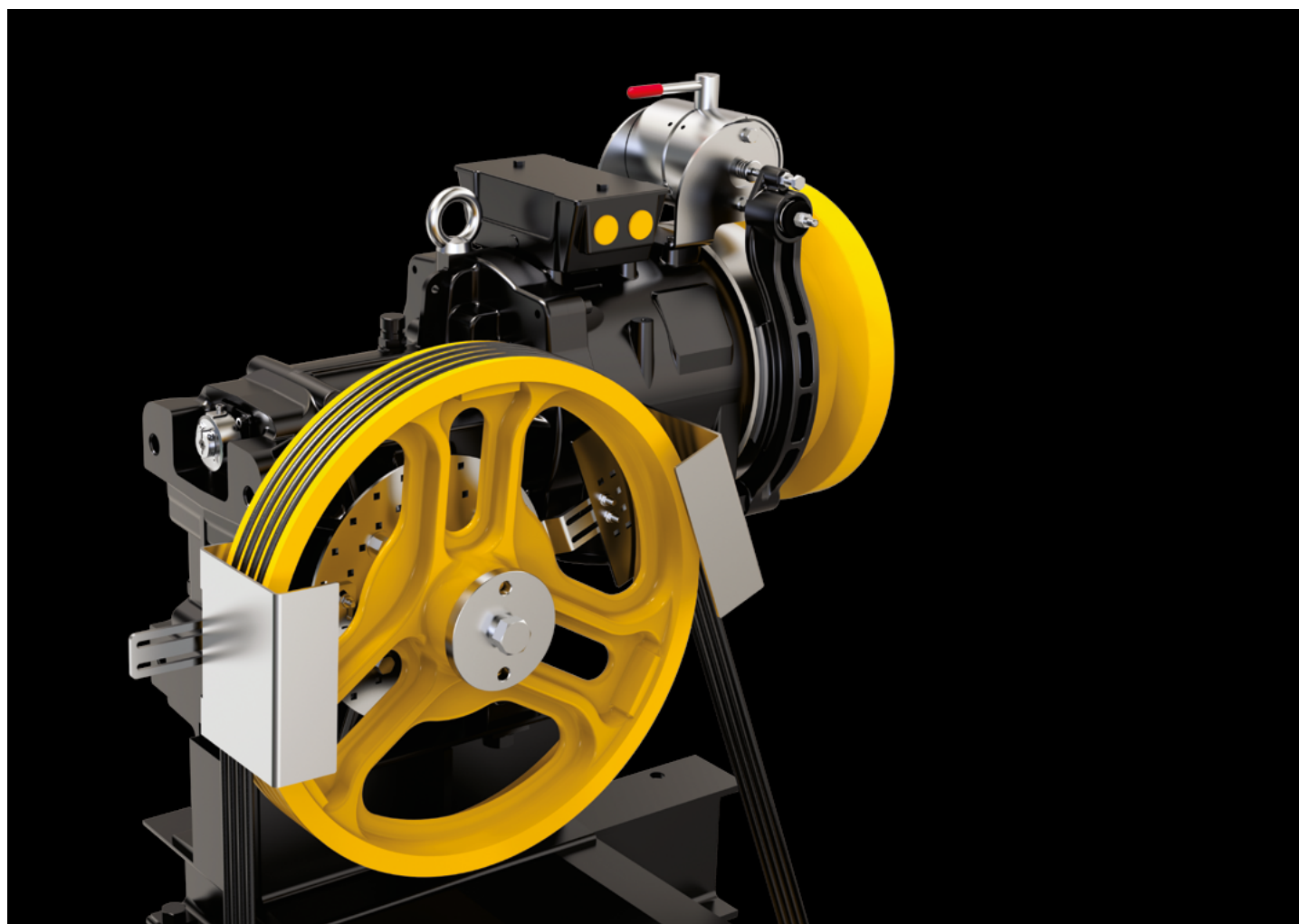

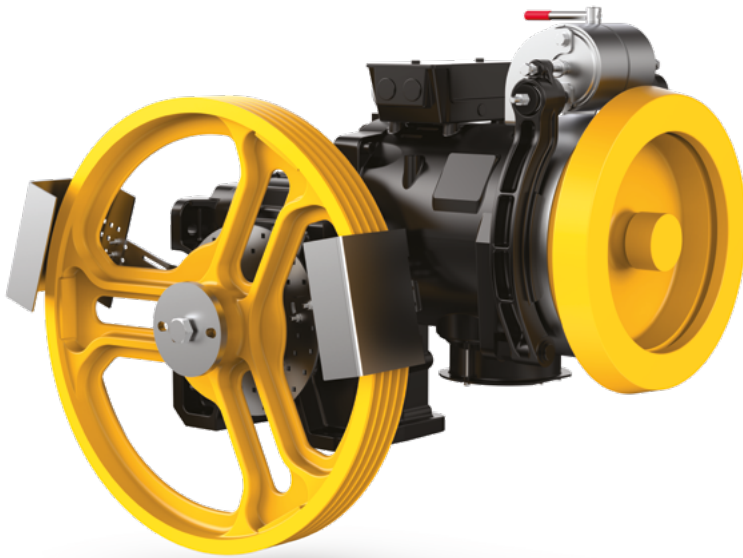

Max. Static Load **28,4 kN - 2900 kg**
 Power Range 50 Hz 4 poles VVVF **5,5 ÷ 7,5 kW**
 Power Range 50 Hz 4/16 poles **5,5 ÷ 7,5 kW**
 Power Range 60 Hz 4 poles VVVF **6 ÷ 8,2 kW**
 Power Range 60 Hz 4/16 poles **6 ÷ 8,2 kW**
 Ratio **1/52; 1/43; 1/37**
 Geared Weight **250 kg**
 Oil capacity **3,7 l**
 Geared machine Rh o Lh (from motor side) **Image ref. to Lh geared**

The geared machine efficiency values are present above each "rated load" table
The motor efficiency values are present in the table "electric motor data"

DIMENSIONS

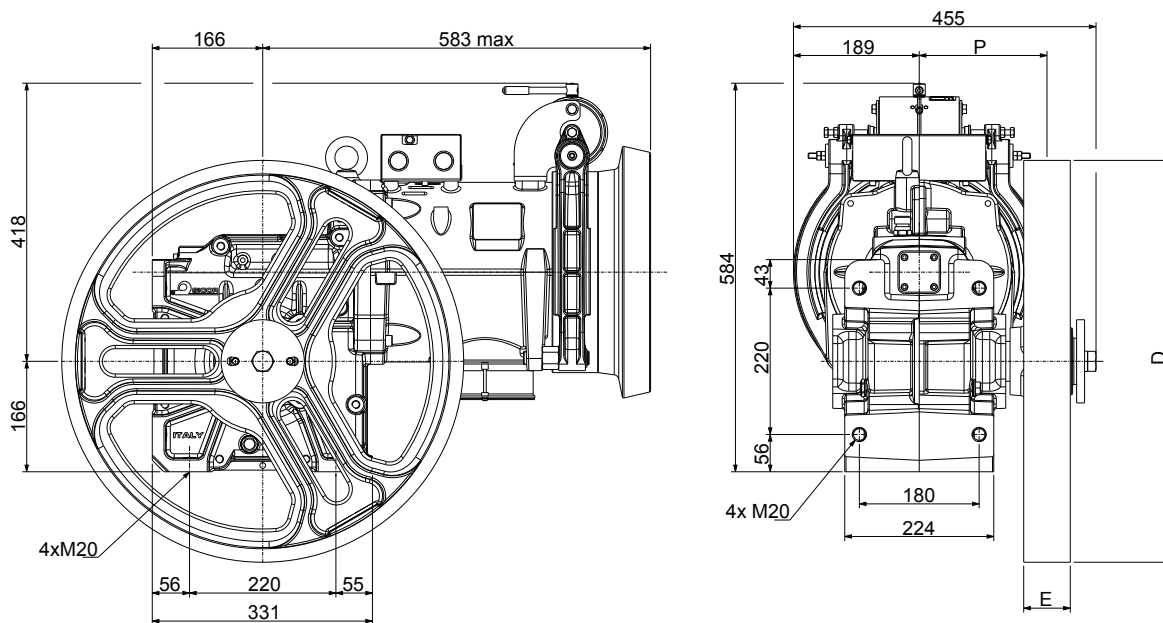

Wrapping System	Traction sheave		Dimension	Load*)	Static Load Direction
	D [mm]	E [mm]			
CSW	480	90	197	28,4 - 2900	
	520				
	550				
	600	70	192		

*) Max. static load on the slow shaft: CSW: Conventional single wrap

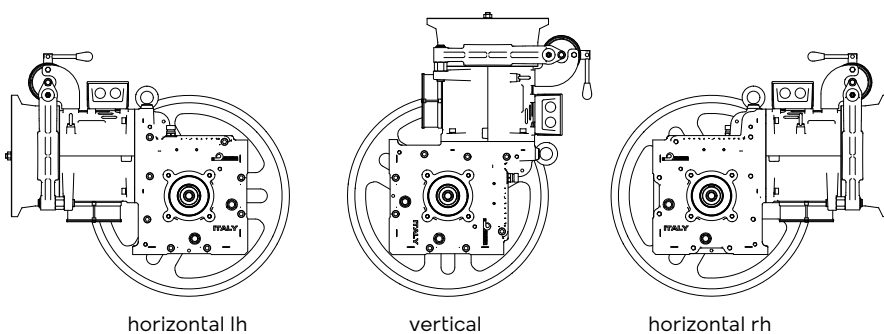

Brake Electromagnet		
[V]	[A]	[W]
24	5,25	126
48	2,30	110
60	1,77	106
80	1,50	120
110	1,02	112
200	0,63	126

		50Hz					60Hz				
		VVVF 1500 rpm 4 Poles AC2 1500/375 rpm 4/16 Poles					VVVF 1800 rpm 4 Poles AC2 1800/450 rpm 4/16 Poles				
		Motor Output [kW]									
		VVVF/AC2 5,5	AC2 6,8	VVVF 7,5	AC2 7,5		VVVF/AC2 6	AC2 7,4	VVVF 8,2	AC2 8,2	
R.R.	Traction Sheave Ø	Speed syn.	Max Rated Load				Speed syn.	Max Rated Load			
[i]	[mm]	[m/s]	[kg]	[kg]	[kg]	[kg]	[m/s]	[kg]	[kg]	[kg]	[kg]
1/52	480	0,72	820	--	--	--	0,87	750	--	--	--
1/52	520	0,79	755	--	--	--	0,94	695	--	--	--
1/52	550	0,83	715	--	--	--	1,00	655	--	--	--
1/43	480	0,88	755	820	820	--	1,05	680	745	745	--
1/52	600	0,91	655	--	--	--	1,09	600	--	--	--
1/43	520	0,95	695	755	755	--	1,14	630	690	690	--
1/43	550	1,00	660	715	715	--	1,21	595	650	650	--
1/37	480	1,02	665	745	745	--	1,22	595	745	745	--
1/43	600	1,10	605	655	655	--	1,32	545	595	595	--
1/37	520	1,10	610	690	690	--	1,32	550	690	690	--
1/37	550	1,17	580	650	650	--	1,40	520	650	650	--
1/37	600	1,27	530	595	595	--	1,53	475	595	595	--

		50Hz					60Hz				
		Motor Output [kW]									
		VVVF/AC2 5,5	AC2 6,8	VVVF 7,5	AC2 7,5		VVVF/AC2 6	AC2 7,4	VVVF 8,2	AC2 8,2	
R.R.		Max Output Torque	Geared Efficiency				Max Output Torque	Geared Efficiency			
[i]		[Nm]									
1/52		1210	0,76	0,77	0,78	0,78	1110	0,75	0,77	0,77	0,77
1/43		1210	0,78	0,79	0,80	0,80	1100	0,77	0,79	0,79	0,79
1/37		1100	0,79	0,81	0,82	0,82	1100	0,78	0,80	0,81	0,81

Rated load values listed in the table include the weight of the ropes. To know the theoretical load, subtract the weight of the ropes.
Position Of The Geared = Top Counterweight = 50% Plant efficiency = 0,80

ELECTRIC MOTOR DATA

		50Hz					60Hz				
		VVVF 1500 rpm 4 Poles AC2 1500/375 rpm 4/16 Poles					VVVF 1800 rpm 4 Poles AC2 1800/450 rpm 4/16 Poles				
		Asynchronous Rated Power [kW]									
		VVVF 5,5	VVVF 7,5	AC2 5,5	AC2 6,8	AC2 7,5	VVVF 6	VVVF 8,2	AC2 6	AC2 7,4	AC2 8,2
		Motor Parameters									
Rated Voltage (star connection) ⁽¹⁾⁽³⁾	[V]	400	400	400	400	400	400	400	400	400	400
Frequency	[Hz]	50	50	50	50	50	60	60	60	60	60
Synchronous Speed	[rpm]	1500	1500	1500/375	1500/375	1500/375	1800	1800	1800/450	1800/450	1800/450
Asynchronous Speed	[rpm]	1424	1426	1370/285	1414/310	1350/297	1708	1741	1680/380	1700/370	1670/350
Rated Current ⁽²⁾	[A]	12,4	17,8	15/15,5	16,8/14	18,3/14,9	15,5	19	17,8/13,5	16,4/13,8	19,2/15
Rated Torque	[Nm]	36,9	49,4	38,3	46	53	33,5	45	34	41	47
Cos φ Power Factor	[]	0,78	0,72	0,70	0,67	0,78	0,70	0,72	0,78	0,73	0,76
Starting Current	[A]	51	95	52	80	65	80	125	52	70	60
Starting Torque	[Nm]	78	120	94	113	134	70	93	74	100	110
Duty Cycle	[%]	60	60	30+10	30+10	30+10	60	60	30+10	30+10	30+10
Starts per Hour	[s/h]	240	240	180	180	180	240	240	180	180	180
Insulation Class	[]	F	F	F	F	F	F	F	F	F	F
Degree of Protection IP	[]	IP21	IP21	IP21	IP21	IP21	IP21	IP21	IP21	IP21	IP21

(1) The motors are standard supplied with star connection (Y), the customer can arrange a delta connection (Δ).

(2) The indicated current values are related to 400V voltage. For current values with delta connection, multiply the values by 1,732.

(3) The standard supply voltage is suitable for 380-400V/220-230V power supplies.

The geared machine includes a fan, 1~220...240V, 50/60Hz.

Available on request 115V supply voltage.

TRACTION SHEAVES AND GROOVES NUMBER x ROPES DIAMETER

Wrapping System	Traction sheave		Max n° Grooves x D	Grooves Pitch
	D [mm]	E [mm]		
CSW	480	90	6xD8	14
	480	90	5xD9	17
	480	90	5xD10	17
	480	90	5xD11	17
	480	90	4xD12	19
	520	90	6xD8	14
	520	90	5xD9	17
	520	90	5xD10	17
	520	90	5xD11	17
	520	90	4xD12	19
	520	90	4xD13	19
	550	90	6xD8	14
	550	90	5xD9	17
	550	90	5xD10	17
	550	90	5xD11	17
	550	90	4xD12	19
	550	90	4xD13	19
	600	70	5xD8	14
	600	70	4xD9	17
	600	70	4xD10	17
	600	70	4xD11	17
	600	70	3xD12	19
	600	70	3xD13	19

VCI

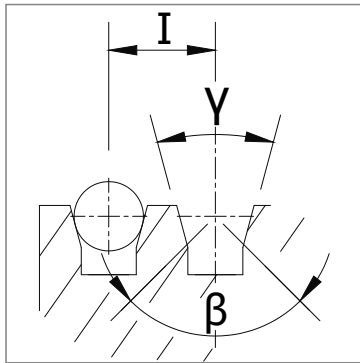

V grooves with undercut

UCI

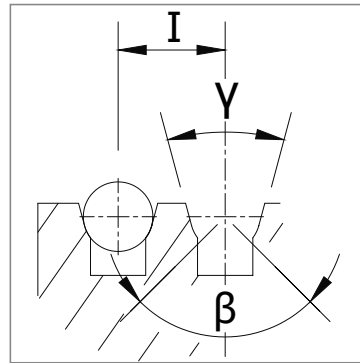

U grooves with undercut

- γ = groove angle
- β = undercut angle
- I = grooves pitch

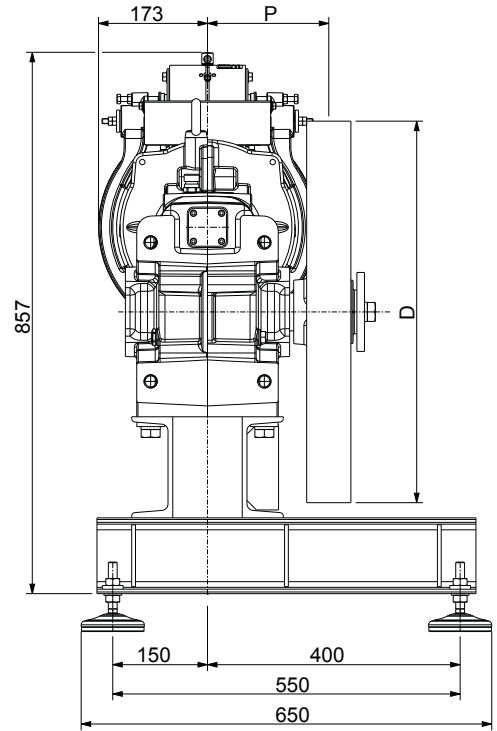
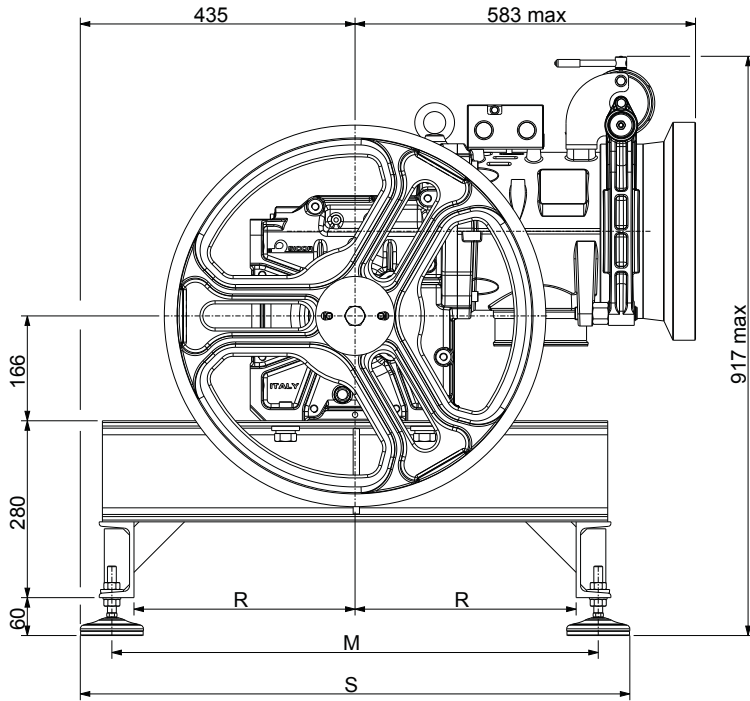

Code	M	R	S
	[mm]	[mm]	[mm]
XTE3020	770	350	870

XTE3020 (D 320-600) (included vibration dampers)
 Weight of machine bedplate: (XTE3020) 53 kg (bedplate + vibration dampers)

VIBRATIONS DAMPER SET UP

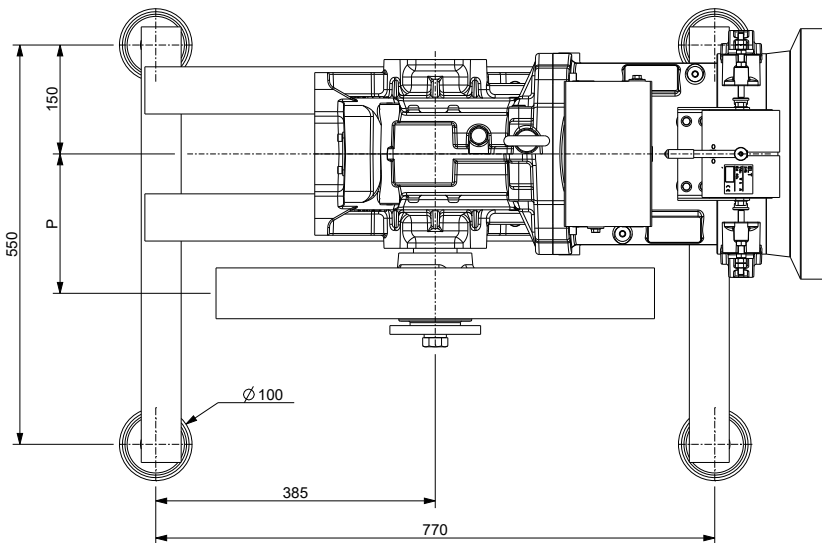

Damper code	Dimension
	[mm]
TAI0110	D.100x28

BEDPLATE | TOP MACHINE WITH DIVERTING PULLEY FOR CSW WRAPPING

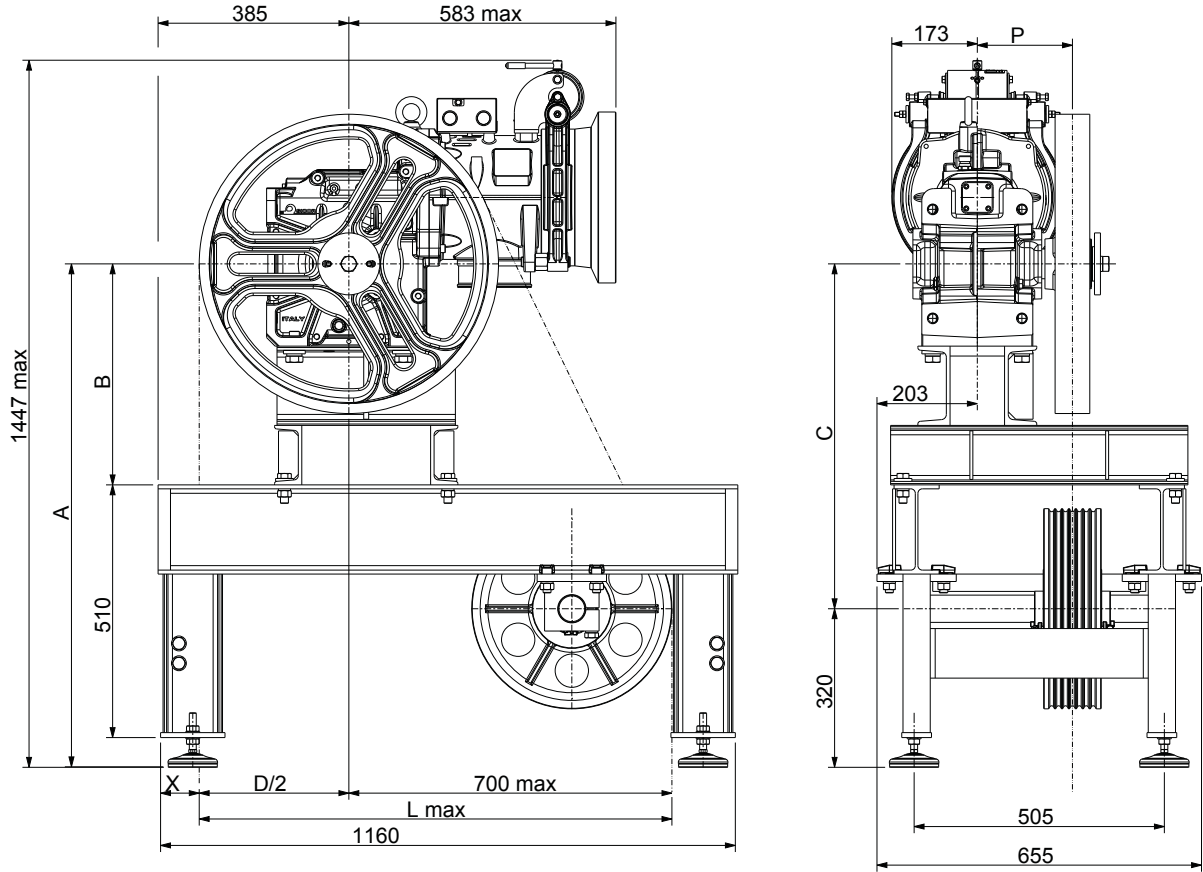

Traction Sheave	X	L max
D [mm]	[mm]	[mm]
480	140	940
520	120	960
550	105	975
600	80	1000

Diverting Pulley	A	B	C
Dt [mm]			
400	1016	280	696
450	1016	280	696
520	1036	300	716

XTE3022 (Dt 400-450) - XTE3023 (Dt 520) (included vibration dampers)
 Weight of machine bedplate: (XTE3022) 138 kg, (XTE3023) 148 kg (bedplate + diverting pulley + vibration dampers)

VIBRATIONS DAMPER SET UP

Damper code	Dimension
	[mm]
TAI0110	D.100x28

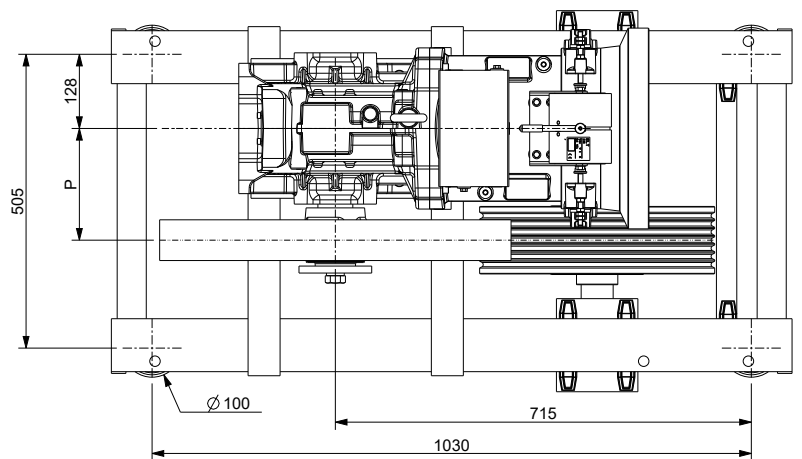

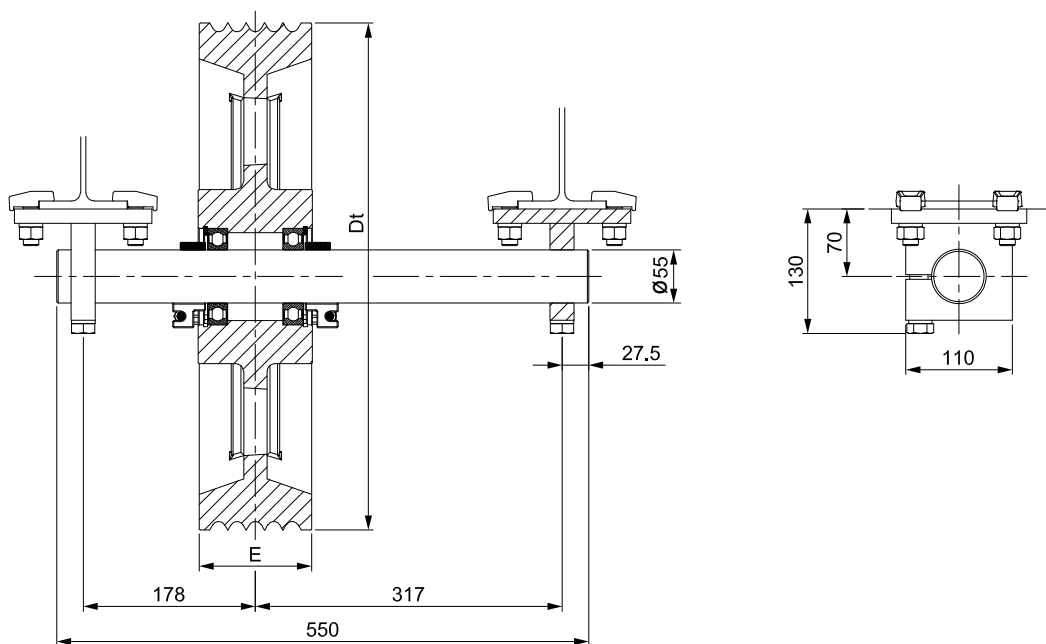

Diverting Pulley		Max n°Grooves x D	Grooves Pitch
Dt [mm]	E [mm]	n° x mm	l [mm]
400	116	7xD8	14
450		6xD11	17
520		5xD13	19

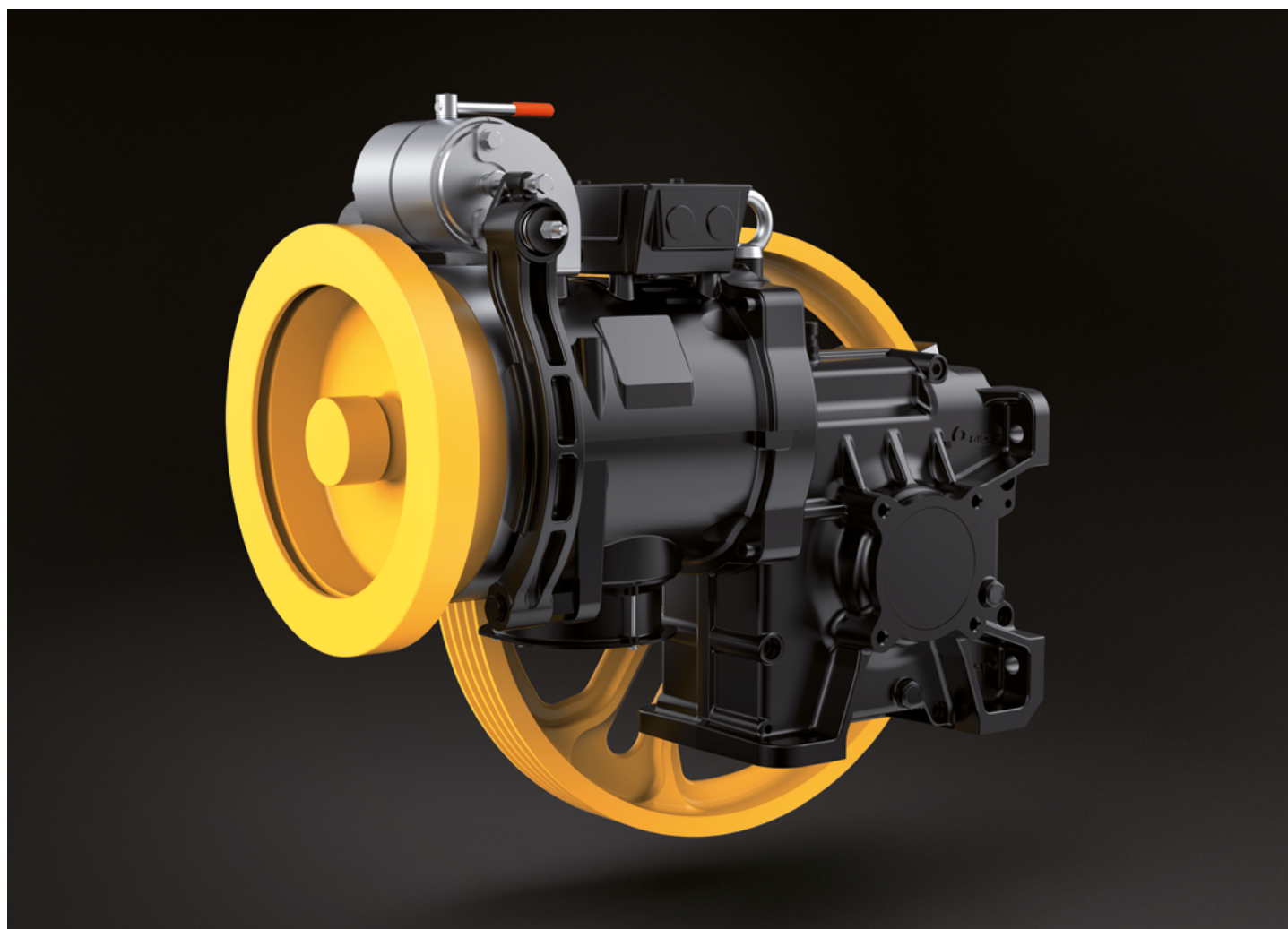

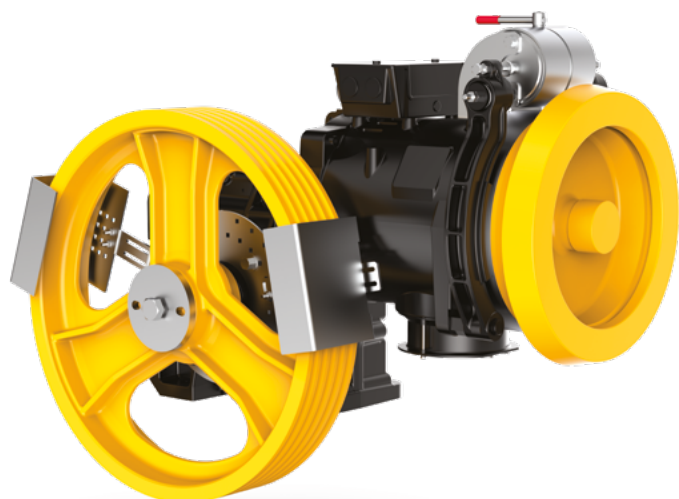

Max. Static Load	32,4 kN - 3300 kg
Power Range 50 Hz 4 poles VVVF	4 ÷ 11 kW
Power Range 50 Hz 4/16 poles	4 ÷ 9 kW
Power Range 50 Hz 6 poles VVVF	2,7 ÷ 5 kW
Power Range 50 Hz 6/16 poles	2,7 ÷ 4,5 kW
Power Range 60 Hz 4 poles VVVF	4,4 ÷ 12 kW
Power Range 60 Hz 4/16 poles	4,4 ÷ 10 kW
Power Range 60 Hz 6 poles VVVF	4 ÷ 5,5 kW
Power Range 60 Hz 6/16 poles	4 ÷ 4,9 kW
Ratio	1/71; 1/59; 1/52; 1/45; 1/37; 2/71; 2/53; 3/47
Geared Weight	280 kg
Oil capacity	3,6 l
Geared machine Rh o Lh (from motor side)	Image ref. to Lh geared

The geared machine efficiency values are present above each "rated load" table
The motor efficiency values are present in the table "electric motor data"

DIMENSIONS

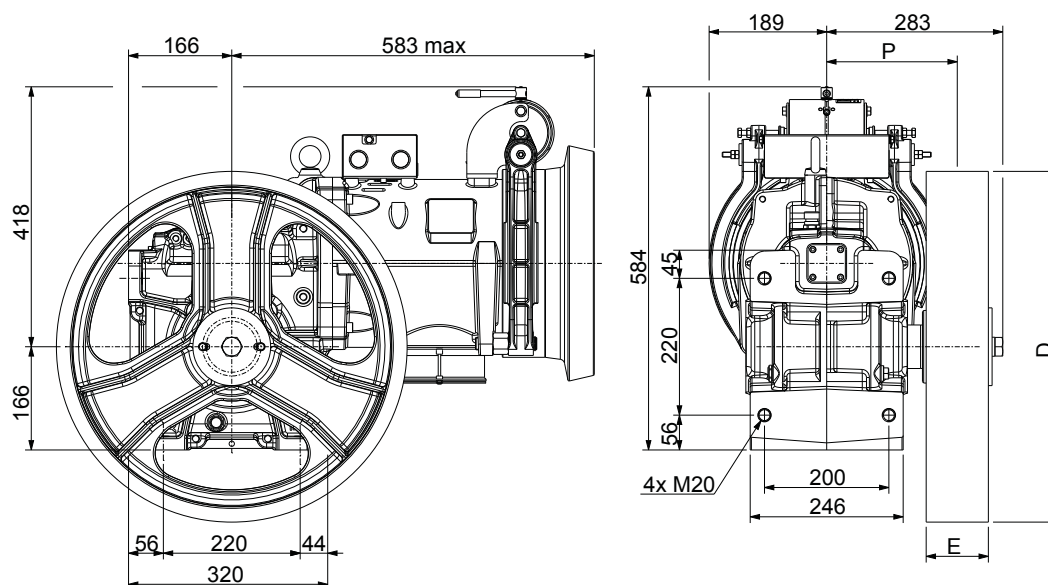

Wrapping System	Traction sheave		Dimension	Load*)	Static Load Direction
	D [mm]	E [mm]			
CSW	360	100	210	32,4 - 3300	<div style="text-align: center;"> 100% ↑ 100% ← → 100% ↓ 100% </div>
	400				
	450				
	480				
	520				
	560				
600					

*) Max. static load on the slow shaft: CSW: Conventional single wrap

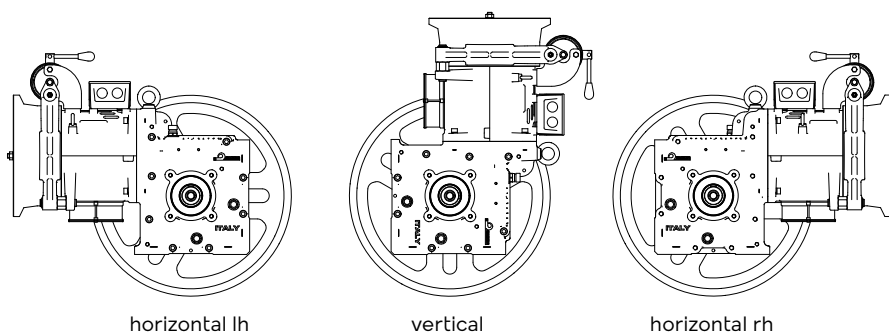

Brake Electromagnet		
[V]	[A]	[W]
24	5,25	126
48	2,30	110
60	1,77	106
80	1,50	120
110	1,02	112
200	0,63	126

		50Hz									60Hz								
		VVVF 1500 rpm 4 Poles AC2 1500/375 rpm 4/16 Poles									VVVF 1800 rpm 4 Poles AC2 1800/450 rpm 4/16 Poles								
		Motor Output [kW]																	
		VVVF AC2 4	VVVF AC2 5,5	AC2 6,8	VVVF 7,5	AC2 7,5	AC2 9	VVVF 9,2	VVVF 11		VVVF AC2 4,4	VVVF AC2 6	AC2 7,4	VVVF 8,2	AC2 8,2	VVVF AC2 10	VVVF 12		
R.R.	Traction Sheave Ø	Speed syn.	Max Rated Load								Speed syn.	Max Rated Load							
[i]	[mm]	[m/s]	[kg]	[kg]	[kg]	[kg]	[kg]	[kg]	[kg]	[kg]	[m/s]	[kg]	[kg]	[kg]	[kg]	[kg]	[kg]		
1/71	360	0,40	950	--	--	--	--	--	--	--	0,48	950	--	--	--	--	--		
1/71	400	0,44	855	--	--	--	--	--	--	--	0,53	855	--	--	--	--	--		
1/59	360	0,48	925	950	--	--	--	--	--	--	0,58	840	950	--	--	--	--		
1/71	450	0,50	760	--	--	--	--	--	--	--	0,60	760	--	--	--	--	--		
1/71	480	0,53	710	--	--	--	--	--	--	--	0,64	710	--	--	--	--	--		
1/59	400	0,53	835	950	--	--	--	--	--	--	0,64	755	935	--	--	--	--		
1/52	360	0,54	835	950	--	--	--	--	--	--	0,65	755	950	--	--	--	--		
1/71	520	0,58	655	--	--	--	--	--	--	--	0,69	655	--	--	--	--	--		
1/59	450	0,60	740	910	--	--	--	--	--	--	0,72	670	830	--	--	--	--		
1/52	400	0,60	750	950	--	--	--	--	--	--	0,72	680	950	--	--	--	--		
1/71	560	0,62	610	--	--	--	--	--	--	--	0,74	610	--	--	--	--	--		
1/45	360	0,63	735	950	--	--	--	--	--	--	0,75	665	945	950	950	--	--		
1/59	480	0,64	695	855	--	--	--	--	--	--	0,77	630	780	--	--	--	--		
1/71	600	0,66	570	--	--	--	--	--	--	--	0,80	570	--	--	--	--	--		
1/52	450	0,68	665	950	--	--	--	--	--	--	0,82	605	860	905	905	--	--		
1/59	520	0,69	640	790	--	--	--	--	--	--	0,83	580	720	--	--	--	--		
1/45	400	0,70	660	945	950	950	--	--	--	--	0,84	595	850	950	950	--	--		
1/52	480	0,72	625	890	920	920	--	--	--	--	0,87	565	805	845	845	--	--		
1/59	560	0,75	595	730	--	--	--	--	--	--	0,89	540	665	--	--	--	--		
1/37	360	0,76	625	890	950	950	--	--	--	--	0,92	565	805	950	950	--	--		
1/45	450	0,79	585	840	950	950	--	--	--	--	0,94	530	755	950	950	--	--		
1/52	520	0,79	575	825	850	850	--	--	--	--	0,94	525	745	780	780	--	--		
2/71	360	0,80	605	860	950	950	--	--	--	--	0,96	545	775	950	950	--	--		
1/59	600	0,80	555	685	--	--	--	--	--	--	0,96	505	625	--	--	--	--		
1/45	480	0,84	550	785	950	950	--	--	--	--	1,01	495	710	895	915	915	--		
1/52	560	0,85	535	765	790	790	--	--	--	--	1,01	485	690	725	725	--	--		
1/37	400	0,85	565	800	935	935	--	--	--	--	1,02	510	720	895	895	--	--		
2/71	400	0,88	545	775	855	855	--	--	--	--	1,06	490	695	855	855	--	--		
1/52	600	0,91	500	715	735	735	--	--	--	--	1,09	455	645	675	675	--	--		
1/45	520	0,91	505	725	890	890	--	--	--	--	1,09	460	655	825	845	845	--		
1/37	450	0,96	500	715	830	830	--	--	--	--	1,15	450	640	795	795	--	--		
1/45	560	0,98	470	675	825	825	--	--	--	--	1,17	425	605	765	785	785	--		
2/71	450	1,00	485	690	760	760	--	--	--	--	1,19	435	620	760	760	--	--		
1/37	480	1,02	470	670	780	780	--	--	--	--	1,22	425	600	745	745	--	--		
1/45	600	1,05	440	630	770	770	--	--	--	--	1,26	395	565	715	730	730	--		
2/71	480	1,06	455	645	710	710	--	--	--	--	1,27	410	580	710	710	--	--		
2/53	360	1,07	465	660	830	925	925	950	950	--	1,28	420	595	750	835	835	950		

CONTINUED ON NEXT PAGE →

		50Hz									60Hz								
		VVVF 1500 rpm 4 Poles AC2 1500/375 rpm 4/16 Poles									VVVF 1800 rpm 4 Poles AC2 1800/450 rpm 4/16 Poles								
		Motor Output [kW]																	
		VVVF AC2 4	VVVF AC2 5,5	AC2 6,8	VVVF 7,5	AC2 7,5	AC2 9	VVVF 9,2	VVVF 11		VVVF AC2 4,4	VVVF AC2 6	AC2 7,4	VVVF 8,2	AC2 8,2	VVVF AC2 10	VVVF 12		
R.R.	Traction Sheave Ø	Speed syn.	Max Rated Load								Speed syn.	Max Rated Load							
[i]	[mm]	[m/s]	[kg]	[kg]	[kg]	[kg]	[kg]	[kg]	[kg]	[kg]	[m/s]	[kg]	[kg]	[kg]	[kg]	[kg]	[kg]		
1/37	520	1,10	430	615	720	720	--	--	--	--	1,32	390	555	690	690	--	--	--	
2/71	520	1,15	420	595	655	655	--	--	--	--	1,38	380	535	655	655	--	--	--	
2/53	400	1,19	415	595	750	830	830	950	950	--	1,42	375	535	675	755	755	930	935	
1/37	560	1,19	400	570	665	665	--	--	--	--	1,43	365	515	640	640	--	--	--	
2/71	560	1,24	390	550	610	610	--	--	--	--	1,49	350	495	610	610	--	--	--	
1/37	600	1,27	375	535	625	625	--	--	--	--	1,53	340	480	595	595	--	--	--	
2/71	600	1,33	360	515	570	570	--	--	--	--	1,59	325	465	570	570	--	--	--	
2/53	450	1,33	370	530	665	740	740	895	910	--	1,60	335	475	600	670	670	825	830	
2/53	480	1,42	345	495	625	690	690	840	855	--	1,71	315	445	560	625	625	775	780	
2/53	520	1,54	320	455	575	640	640	775	790	--	1,85	290	410	520	580	580	715	720	
2/53	560	1,66	295	425	535	595	595	720	730	--	1,99	270	380	480	535	535	665	--	
2/53	600	1,78	275	395	500	555	555	670	685	--	2,13	250	355	450	500	500	620	625	
3/47	360	1,80	280	405	510	565	565	685	700	850	2,17	255	365	460	510	510	635	770	
3/47	400	2,01	255	365	455	510	510	615	630	765	2,41	230	325	410	460	460	570	690	
3/47	450	2,26	225	320	405	450	450	550	560	680	2,71	205	290	365	410	410	505	615	
3/47	480	2,41	210	300	380	425	425	515	525	635	2,89	190	270	345	385	385	475	575	
3/47	520	2,61	195	280	350	390	390	475	485	585	3,13	175	250	315	355	355	435	530	
3/47	560	2,81	180	260	325	360	360	440	450	545	3,37	165	235	295	330	330	405	495	
3/47	600	3,01	170	240	305	340	340	410	420	510	3,61	155	215	275	305	305	380	460	

		50Hz									60Hz								
		Motor Output [kW]									Motor Output [kW]								
		VVVF AC2 4	VVVF AC2 5,5	AC2 6,8	VVVF 7,5	AC2 7,5	AC2 9	VVVF 9,2	VVVF 11		VVVF AC2 4,4	VVVF AC2 6	AC2 7,4	VVVF 8,2	AC2 8,2	VVVF AC2 10	VVVF 12		
R.R.	Max Output Torque	Geared Efficiency								Max Output Torque	Geared Efficiency								
[i]	[Nm]									[Nm]									
1/71	1050	0,69	0,72	0,73	0,73	0,73	0,74	0,74	0,75	1050	0,68	0,71	0,72	0,73	0,73	0,74	0,74		
1/59	1260	0,72	0,74	0,76	0,76	0,76	0,77	0,77	0,78	1150	0,71	0,74	0,75	0,76	0,76	0,77	0,77		
1/52	1360	0,73	0,76	0,77	0,78	0,78	0,79	0,79	0,80	1250	0,72	0,75	0,77	0,78	0,78	0,79	0,79		
1/45	1420	0,74	0,77	0,79	0,79	0,79	0,80	0,81	0,81	1350	0,74	0,77	0,78	0,79	0,79	0,80	0,81		
1/37	1150	0,77	0,80	0,81	0,82	0,82	0,83	0,83	0,84	1100	0,76	0,79	0,81	0,81	0,81	0,82	0,83		
2/71	1050	0,78	0,80	0,82	0,82	0,82	0,83	0,83	0,84	1050	0,77	0,80	0,81	0,82	0,82	0,83	0,83		
2/53	1260	0,80	0,83	0,84	0,85	0,85	0,86	0,86	0,87	1150	0,79	0,82	0,84	0,84	0,84	0,86	0,86		
3/47	1240	0,83	0,86	0,87	0,88	0,88	0,89	0,89	0,90	1140	0,82	0,85	0,87	0,87	0,87	0,89	0,89		

Rated load values listed in the table include the weight of the ropes.

To know the theoretical load, subtract the weight of the ropes.

Position Of The Geared = Top Counterweight = 50% Plant efficiency = 0,80

		50Hz						60Hz					
		VVVF 1000 rpm 6 Poles AC2 1000/375 rpm 6/16 Poles						VVVF 1200 rpm 6 Poles AC2 1200/450 rpm 6/16 Poles					
		Motor Output [kW]											
		VVVF/AC2 2,7	VVVF/AC2 3,6	VVVF 4,2	AC2 4,5	VVVF 5							
R.R.	Traction Sheave Ø	Speed syn.	Max Rated Load					Speed syn.	Max Rated Load				
[i]	[mm]	[m/s]	[kg]	[kg]	[kg]	[kg]	[kg]	[m/s]	[kg]	[kg]	[kg]	[kg]	
1/71	360	0,27	950	--	--	--	--	0,32	950	--	--	--	
1/71	400	0,29	855	--	--	--	--	0,35	855	--	--	--	
1/59	360	0,32	945	950	--	--	--	0,38	950	--	--	--	
1/71	450	0,33	760	--	--	--	--	0,40	760	--	--	--	
1/71	480	0,35	710	--	--	--	--	0,42	710	--	--	--	
1/59	400	0,35	850	950	--	--	--	0,43	950	--	--	--	
1/52	360	0,36	850	950	--	--	--	0,43	950	--	--	--	
1/71	520	0,38	655	--	--	--	--	0,46	655	--	--	--	
1/59	450	0,40	755	910	--	--	--	0,48	910	--	--	--	
1/52	400	0,40	765	950	--	--	--	0,48	950	--	--	--	
1/71	560	0,41	610	--	--	--	--	0,50	610	--	--	--	
1/45	360	0,42	750	950	--	--	--	0,50	945	950	950	--	
1/59	480	0,43	705	855	--	--	--	0,51	855	--	--	--	
1/71	600	0,44	570	--	--	--	--	0,53	570	--	--	--	
1/52	450	0,45	680	935	950	950	--	0,54	860	950	950	--	
1/59	520	0,46	650	790	--	--	--	0,55	790	--	--	--	
1/45	400	0,47	675	930	950	950	--	0,56	850	950	950	--	
1/52	480	0,48	635	875	920	920	--	0,58	805	920	920	--	
1/59	560	0,50	605	730	--	--	--	0,60	730	--	--	--	
1/37	360	0,51	640	875	950	950	--	0,61	805	950	950	--	
1/45	450	0,52	600	825	950	950	--	0,63	755	905	945	950	
1/52	520	0,52	590	810	850	850	--	0,63	745	850	850	--	
2/71	360	0,53	615	845	950	950	--	0,64	775	925	950	950	
1/59	600	0,53	565	685	--	--	--	0,64	685	--	--	--	
1/45	480	0,56	560	775	915	950	950	0,67	710	850	885	950	
1/52	560	0,56	545	750	790	790	--	0,68	690	790	790	--	
1/37	400	0,57	575	790	935	935	--	0,68	725	865	905	935	
2/71	400	0,59	555	760	855	855	--	0,71	700	835	855	855	
1/52	600	0,60	510	700	735	735	--	0,72	645	735	735	--	
1/45	520	0,61	515	715	845	890	890	0,73	655	780	820	890	
1/37	450	0,64	510	700	830	830	--	0,76	645	770	805	830	
1/45	560	0,65	480	665	785	825	825	0,78	610	725	760	825	
2/71	450	0,66	495	675	760	760	--	0,80	620	740	760	760	
1/37	480	0,68	480	655	775	780	780	0,82	605	720	755	780	
1/45	600	0,70	450	620	730	770	770	0,84	565	680	710	770	
2/71	480	0,71	460	635	710	710	--	0,85	580	695	710	710	
2/53	360	0,71	470	650	770	825	925	0,85	595	710	745	845	

CONTINUED ON NEXT PAGE →

		50Hz						60Hz							
		VVVF 1000 rpm 6 Poles AC2 1000/375 rpm 6/16 Poles						VVVF 1200 rpm 6 Poles AC2 1200/450 rpm 6/16 Poles							
		Motor Output [kW]													
		VVVF/AC2 2,7	VVVF/AC2 3,6	VVVF 4,2	AC2 4,5	VVVF 5						VVVF/AC2 4	VVVF 4,7	AC2 4,9	VVVF 5,5
R.R.	Traction Sheave Ø	Speed syn.	Max Rated Load					Speed syn.	Max Rated Load						
[i]	[mm]	[m/s]	[kg]	[kg]	[kg]	[kg]	[kg]	[m/s]	[kg]	[kg]	[kg]	[kg]	[kg]		
1/37	520	0,74	440	605	715	720	720	0,88	555	665	695	720			
2/71	520	0,77	425	585	655	655	--	0,92	535	640	655	655			
2/53	400	0,79	425	585	690	745	835	0,95	535	640	670	760			
1/37	560	0,79	410	565	665	665	--	0,95	515	615	645	665			
2/71	560	0,83	395	545	610	610	--	0,99	500	595	610	610			
1/37	600	0,85	380	525	620	625	625	1,02	480	575	600	625			
2/71	600	0,88	370	505	570	570	--	1,06	465	555	570	570			
2/53	450	0,89	375	520	615	660	740	1,07	475	570	595	675			
2/53	480	0,95	355	485	575	620	695	1,14	445	535	555	630			
2/53	520	1,03	325	450	530	570	640	1,23	410	490	515	585			
2/53	560	1,11	305	415	495	530	595	1,33	380	455	475	540			
2/53	600	1,19	280	390	460	495	555	1,42	355	425	445	505			
3/47	360	1,20	290	395	470	505	565	1,44	365	435	455	515			
3/47	400	1,34	260	355	425	455	510	1,60	330	390	410	465			
3/47	450	1,50	230	315	375	405	455	1,80	290	345	365	410			
3/47	480	1,60	215	295	350	380	425	1,93	275	325	340	385			
3/47	520	1,74	200	275	325	350	390	2,09	250	300	315	355			
3/47	560	1,87	185	255	300	325	365	2,25	235	280	290	330			
3/47	600	2,01	170	235	280	305	340	2,41	220	260	270	310			

		50Hz						60Hz							
		VVVF 1000 rpm 6 Poles AC2 1000/375 rpm 6/16 Poles						VVVF 1200 rpm 6 Poles AC2 1200/450 rpm 6/16 Poles							
		Motor Output [kW]													
		VVVF/AC2 2,7	VVVF/AC2 3,6	VVVF 4,2	AC2 4,5	VVVF 5						VVVF/AC2 4	VVVF 4,7	AC2 4,9	VVVF 5,5
R.R.	Max Output Torque	Geared Efficiency					Max Output Torque	Geared Efficiency							
[i]	[Nm]						[Nm]								
1/71	1050	0,70	0,72	0,73	0,73	0,73	1050	0,71	0,72	0,72	0,73				
1/59	1260	0,72	0,74	0,75	0,76	0,76	1260	0,74	0,75	0,75	0,76				
1/52	1360	0,74	0,76	0,77	0,77	0,78	1360	0,75	0,77	0,77	0,78				
1/45	1420	0,75	0,78	0,79	0,79	0,80	1420	0,77	0,78	0,78	0,79				
1/37	1150	0,78	0,80	0,81	0,82	0,82	1150	0,79	0,81	0,81	0,82				
2/71	1050	0,78	0,81	0,82	0,82	0,82	1050	0,80	0,81	0,81	0,82				
2/53	1260	0,80	0,83	0,84	0,84	0,85	1260	0,82	0,83	0,84	0,84				
3/47	1240	0,83	0,86	0,87	0,88	0,88	1240	0,85	0,87	0,87	0,88				

Rated load values listed in the table include the weight of the ropes.

To know the theoretical load, subtract the weight of the ropes.

Position Of The Geared = Top Counterweight = 50% Plant efficiency = 0,80

50Hz										
VVVF 1500 rpm 4 Poles AC2 1500/375 rpm 4/16 Poles										
Asynchronous Rated Power [kW]										
	VVVF 4	VVVF 5,5	VVVF 7,5	VVVF 9,2	VVVF 11	AC2 4	AC2 5,5	AC2 6,8	AC2 7,5	AC2 9
Motor Parameters										
Rated Voltage (star connection) ^{(1) (3)}	[V]	400	400	400	400	400	400	400	400	400
Frequency	[Hz]	50	50	50	50	50	50	50	50	50
Synchronous Speed	[rpm]	1500	1500	1500	1500	1500	1500/375	1500/375	1500/375	1500/375
Asynchronous Speed	[rpm]	1423	1424	1450	1458	1457	1359/276	1359/280	1325/267	1350/297
Rated Current ⁽²⁾	[A]	9,4	12,4	17,8	22,5	24,1	11,3/11,1	15/15,5	16,5/10,8	18,3/14,9
Rated Torque	[Nm]	26,8	36,9	49,4	60	72	28,1	38,7	49	53
Cos φ Power Factor	[]	0,76	0,78	0,72	0,70	0,76	0,64	0,69	0,8	0,78
Starting Current	[A]	41	51	95	130	157	39	52	65	65
Starting Torque	[Nm]	54	78	120	158	163	79	94	114	134
Duty Cycle	[%]	60	60	60	60	60	30+10	30+10	30+10	30+10
Starts per Hour	[s/h]	240	240	240	240	240	180	180	180	180
Insulation Class	[]	F	F	F	F	F	F	F	F	F
Degree of Protection IP	[]	IP21	IP21	IP21	IP21	IP21	IP21	IP21	IP21	IP21

(1) The motors are standard supplied with star connection (Y), the customer can arrange a delta connection (Δ).

(2) The indicated current values are related to 400V voltage. For current values with delta connection, multiply the values by 1,732.

(3) The standard supply voltage is suitable for 380-400V/220-230V power supplies.

The geared machine includes a fan, 1~220...240V, 50/60Hz.

Available on request 115V supply voltage.

50Hz							
VVVF 1000 rpm 6 Poles AC2 1000/375 rpm 6/16 Poles							
Asynchronous Rated Power [kW]							
	VVVF 2,7	VVVF 3,6	VVVF 4,2	VVVF 5	AC2 2,7	AC2 3,6	AC2 4,5
Motor Parameters							
Rated Voltage (star connection) ^{(1) (3)}	[V]	400	400	400	400	400	400
Frequency	[Hz]	50	50	50	50	50	50
Synchronous Speed	[rpm]	1000	1000	1000	1000	1000/375	1000/375
Asynchronous Speed	[rpm]	955	962	947	957	893/268	917/270
Rated Current ⁽²⁾	[A]	8,4	10,9	14,1	15,2	10,9/11,5	15/12,4
Rated Torque	[Nm]	27	35,7	41,2	50	28,9	37,2
Cos φ Power Factor	[]	0,61	0,62	0,54	0,65	0,52	0,50
Starting Current	[A]	30	43	63	72	29	39
Starting Torque	[Nm]	46	80	100	105	69	98
Duty Cycle	[%]	60	60	60	60	30+10	30+10
Starts per Hour	[s/h]	240	240	240	240	180	180
Insulation Class	[]	F	F	F	F	F	F
Degree of Protection IP	[]	IP21	IP21	IP21	IP21	IP21	IP21

(1) The motors are standard supplied with star connection (Y), the customer can arrange a delta connection (Δ).

(2) The indicated current values are related to 400V voltage. For current values with delta connection, multiply the values by 1,732.

(3) The standard supply voltage is suitable for 380-400V/220-230V power supplies.

The geared machine includes a fan, 1~220...240V, 50/60Hz.

Available on request 115V supply voltage.

60Hz

VVVF 1800 rpm 4 Poles
AC2 1800/450 rpm 4/16 Poles

Asynchronous Rated Power [kW]

VVVF 4,4	VVVF 6	VVVF 8,2	VVVF 10	VVVF 12	AC2 4,4	AC2 6	AC2 7,4	AC2 8,2	AC2 10
Motor Parameters									
400	400	400	400	400	400	400	400	400	400
60	60	60	60	60	60	60	60	60	60
1800	1800	1800	1800	1800	1800/450	1800/450	1800/450	1800/450	1800/450
1714	1708	1741	1751	1748	1606/330	1680/380	1665/345	1670/362	1664/373
10,2	15,2	19	22,5	25,5	11,8/10	18/14	16,5/11,5	19,2/15	22/18,4
24,5	33,5	45	54,5	65	26,2	34,1	42	47	56,8
0,75	0,70	0,72	0,72	0,76	0,63	0,78	0,79	0,76	0,80
48	70	88	117	141	39	46	52	60	61
44	70	101	160	171	64	73	85	110	147
60	60	60	60	60	30+10	30+10	30+10	30+10	30+10
240	240	240	240	240	180	180	180	180	180
F	F	F	F	F	F	F	F	F	F
IP21	IP21	IP21	IP21	IP21	IP21	IP21	IP21	IP21	IP21

60Hz

VVVF 1200 rpm 6 Poles
AC2 1200/450 rpm 6/16 Poles

Asynchronous Rated Power [kW]

VVVF 4	VVVF 4,7	VVVF 5,5	AC2 4	AC2 4,9
Motor Parameters				
400	400	400	400	400
60	60	60	60	60
1200	1200	1200	1200/450	1200/450
1138	1160	1148	1096/318	1106/411
12,4	15,4	15	18,7/14,3	15,3/13,2
33,6	38,7	46	34,8	42,3
0,60	0,55	0,70	0,58	0,70
49	67	138	--	--
62	74	154	--	--
60	60	60	30+10	30+10
240	240	240	180	180
F	F	F	F	F
IP21	IP21	IP21	IP21	IP21

Wrapping System	Traction sheave		Max n° Grooves x D	Grooves Pitch
	D [mm]	E [mm]	n° x mm	l [mm]
CSW	360	100	6xD8	14
	360	100	5xD9 (6xD9)	17 (16)
	400	100	6xD8	14
	400	100	5xD9 (6xD9)	17 (16)
	400	100	5xD10 (6xD10)	17 (16)
	450	100	6xD8	14
	450	100	5xD9 (6xD9)	17 (16)
	450	100	5xD10 (6xD10)	17 (16)
	450	100	5xD11 (6xD11)	17 (16)
	480	100	6xD8	14
	480	100	5xD9 (6xD9)	17 (16)
	480	100	5xD10 (6xD10)	17 (16)
	480	100	5xD11 (6xD11)	17 (16)
	480	100	4xD12	19
	520	100	6xD8	14
	520	100	5xD9 (6xD9)	17 (16)
	520	100	5xD10 (6xD10)	17 (16)
	520	100	5xD11 (6xD11)	17 (16)
	520	100	4xD12	19
	520	100	4xD13	19
	560	100	6xD8	14
	560	100	5xD9 (6xD9)	17 (16)
	560	100	5xD10 (6xD10)	17 (16)
	560	100	5xD11 (6xD11)	17 (16)
	560	100	4xD12	19
	560	100	4xD13	19
	600	100	6xD8	14
	600	100	5xD9 (6xD9)	17 (16)
	600	100	5xD10 (6xD10)	17 (16)
	600	100	5xD11 (6xD11)	17 (16)
600	100	4xD12	19	
600	100	4xD13	19	

VCI

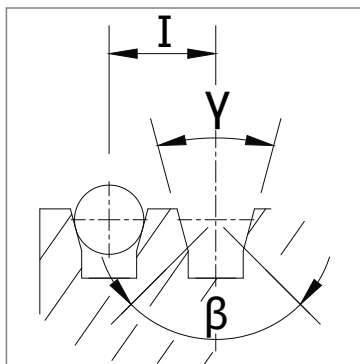

V grooves with undercut

UCI

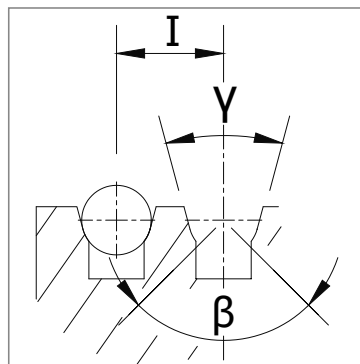

U grooves with undercut

γ = groove angle
 β = undercut angle
 I = grooves pitch

BEDPLATE | TOP MACHINE WITHOUT DIVERTING PULLEY FOR CSW WINDING

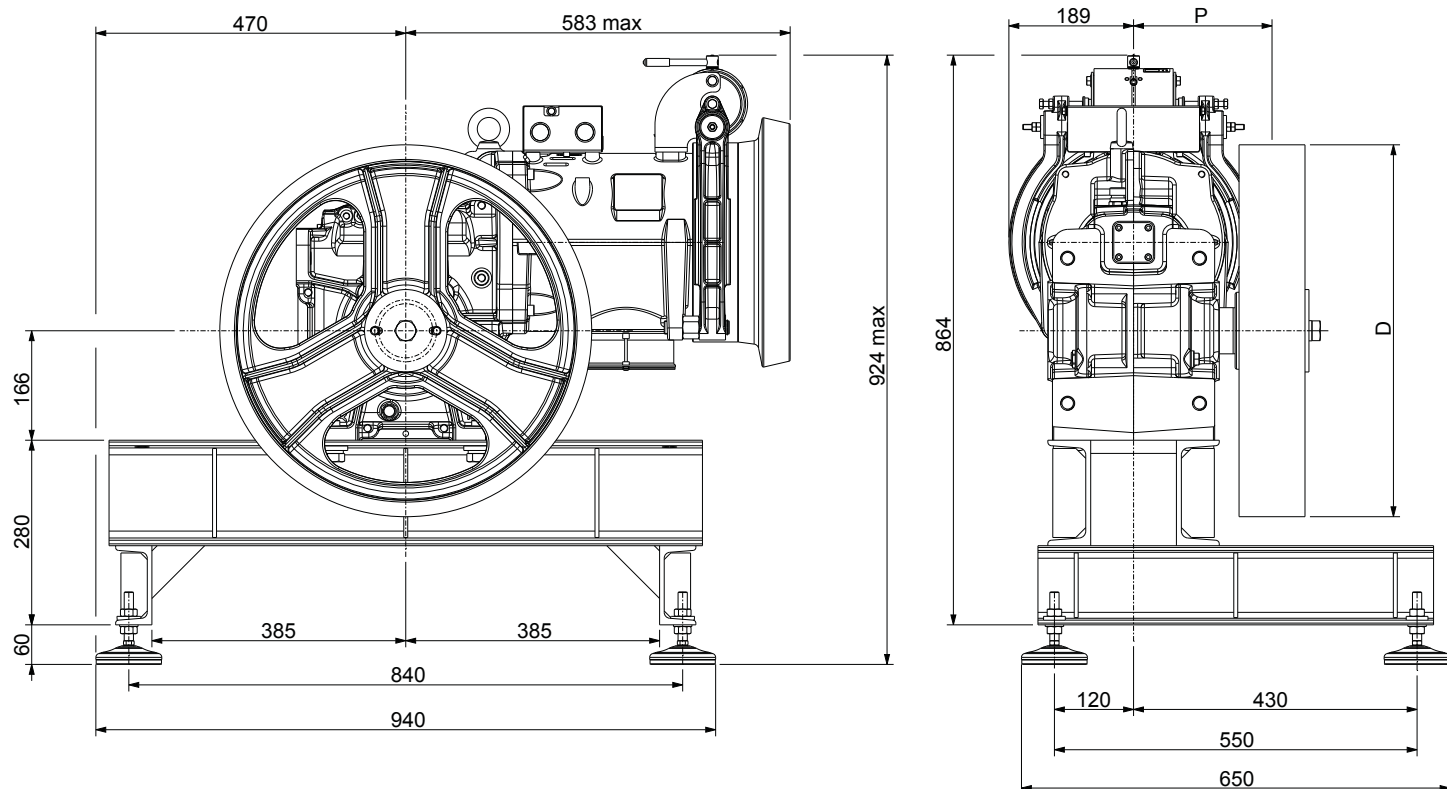

XTE0339 (included vibration dampers)

Weight of machine bedplate: 67 kg (bedplate + vibration dampers)

VIBRATIONS DAMPER SET UP

Damper code	Dimension
	[mm]
TAI0110	D.100x28

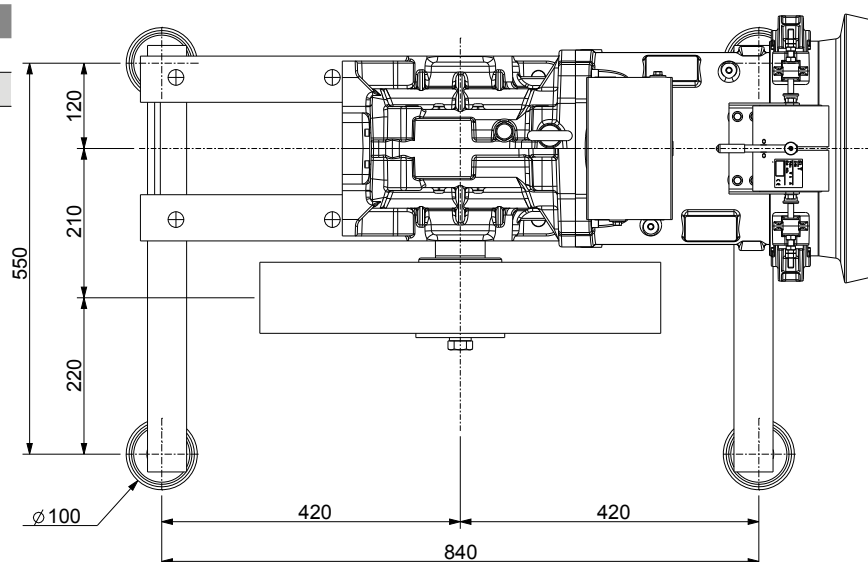

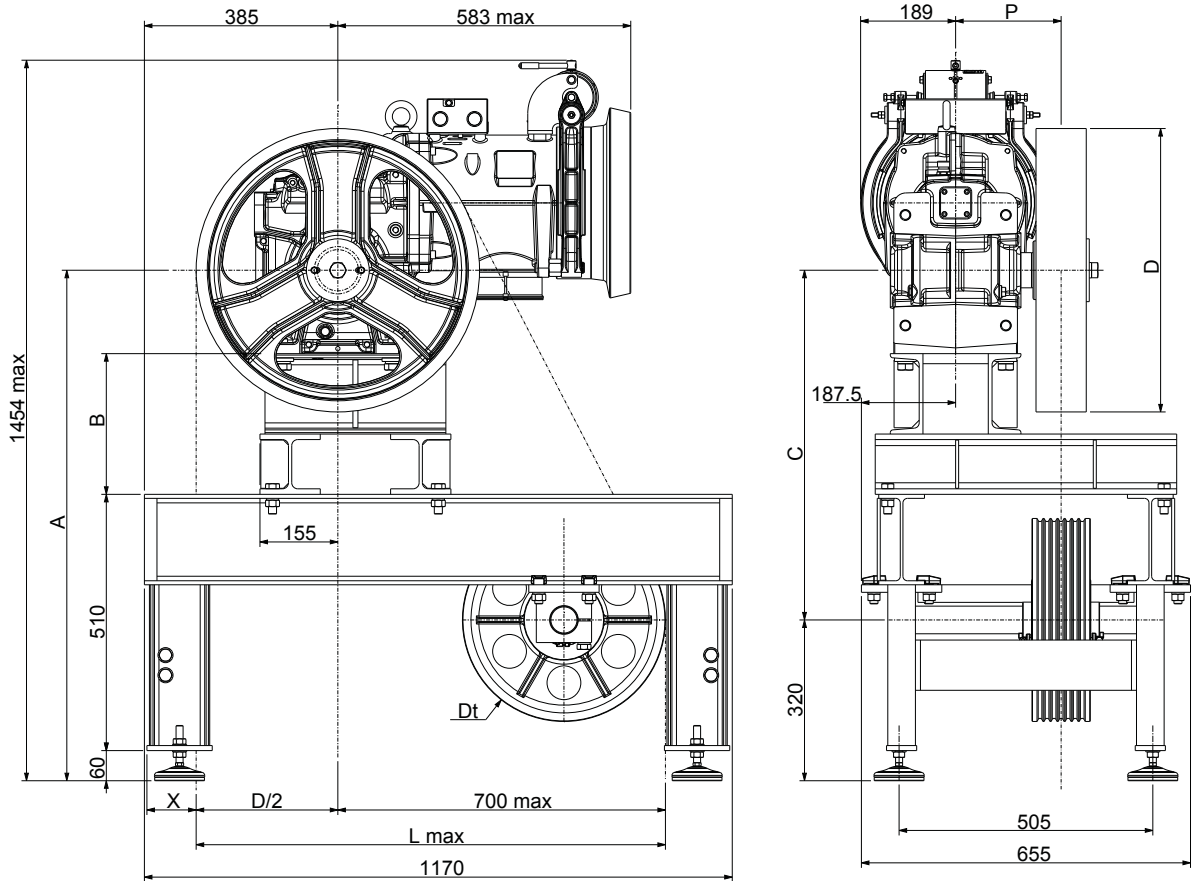

Traction Sheave	X	L Max
D [mm]	[mm]	[mm]
360	200	880
400	180	900
450	155	925
480	140	940
520	120	960
560	105	975
600	80	1000

Diverting Pulley	A	B	C
Dt [mm]	[mm]	[mm]	[mm]
400	1016	280	696
450	1016	280	696
520	1036	300	716

XTE6026 (Dt 400-450) - XTE6027 (Dt 520)

Weight of machine bedplate: (XTE6026) 159 Kg, (XTE6027) 176 Kg (bedplate + diverting pulley + vibration dampers)

VIBRATIONS DAMPER SET UP

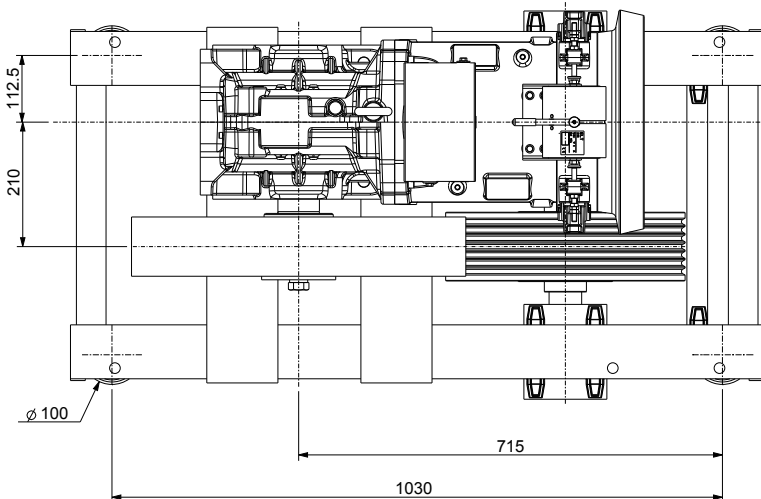

Damper code	Dimension
	[mm]
TAI0110	D.100x28

BEDPLATE SH140 LS | BOTTOM DRIVE MACHINE WITH CSW WRAPPING

(Ropes upwards)

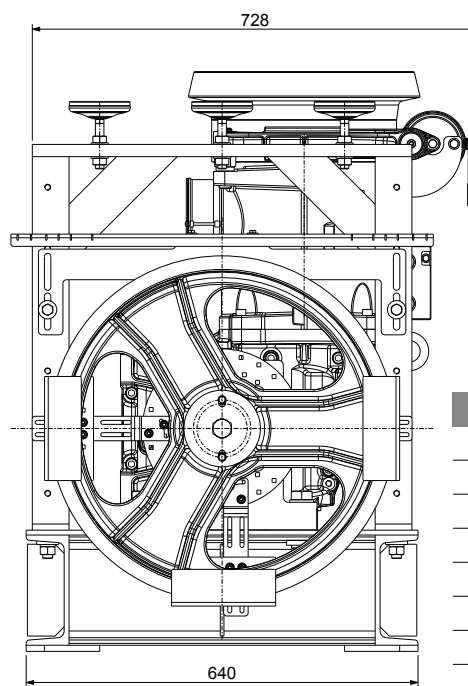
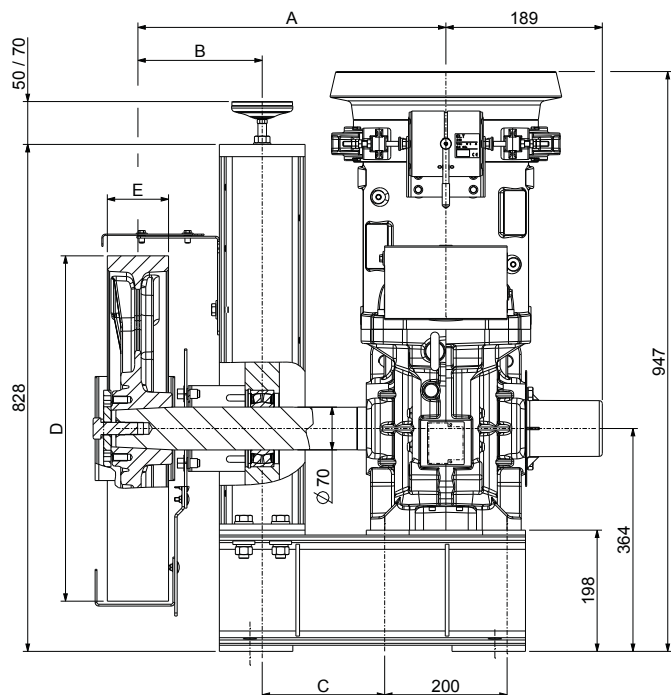

Traction Sheave D	
D [mm]	E [mm]
360	100
400	
450	
480	
520	
560	
600	

Quote "A"	Quote "B"	Quote "C"	Static load	Code*
[mm]	[mm]	[mm]	[kg]	
500	150	250	2000	XTE3727
	175	225	1700	XTE3728
	200	200	1500	XTE3729
600	150	350	2000	XTE3724
	175	325	1700	XTE3725
	200	300	1500	XTE3726
725	150	475	2000	XTE3721
	175	450	1700	XTE3722
	200	425	1500	XTE3723

INSTALLATION POSITION

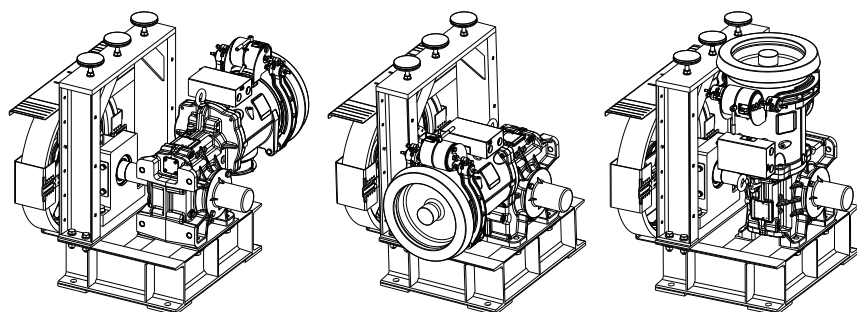

Right hand Machine

Left hand Machine

Vertical Machine

*Always supplied with the machine.

DIVERTING PULLEYS AND GROOVES NUMBER x ROPES DIAMETER

Diverting Pulley		Max n° Grooves x D	Grooves Pitch
Dt [mm]	E [mm]	n° x mm	l [mm]
400	116	7xD8	14
450	116	6xD11	17
520	116	5xD13	19

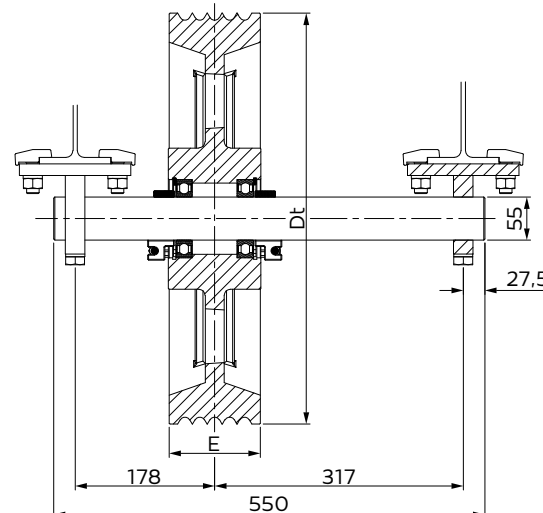
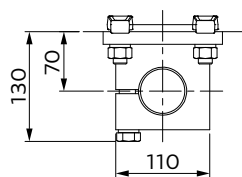



Geared machine Lh

Power Range 50 Hz 4 poles VVVF **5,5 kW**

Ratio **1/52**

Speed synchronous **0,60 m/s**

Geared Weight **350 kg**

Oil capacity **3,6 l**

Geared machine Rh o Lh (from motor side) **Image ref. to Lh geared**

DIMENSIONS

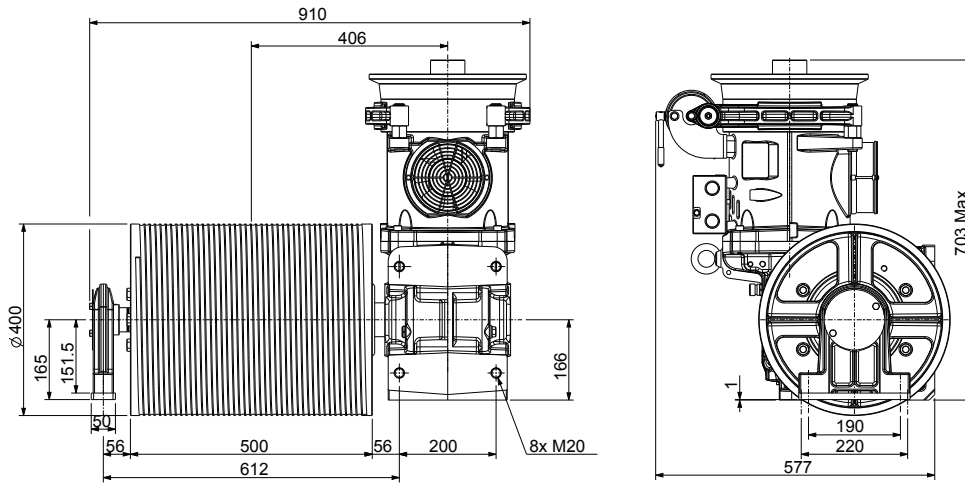

Brake Electromagnet		
[V]	[A]	[W]
24	5,25	126
48	2,30	110
60	1,77	106
80	1,50	120
110	1,02	112
200	0,63	126

DUTY TABLE

Roping 1:1

50Hz
VVVF 1500 rpm 4 Poles
 Motor Output [kW]
VVVF 5,5

R.R.	Traction Drum Ø	Installation frequency	Max Rated Load	Max cabin load	Ropes Nr x diameter Ø	Max travel with 2 parallel ropes
[i]	[mm]	[Hz]	[kg]	[kg]	[mm]	[m]
1/52	400	50	225	300	2 x Ø8	29
					2 x Ø9	26
					2 x Ø10	23

Rated load values listed in the table include the weight of the ropes. To know the theoretical load, subtract the weight of the ropes.
 Position Of The Geared = Top Plant efficiency = 0,85

ELECTRIC MOTOR DATA

50Hz		
VVVF 1500 rpm 4 Poles		
Asynchronous Rated Power [kW]		
VVVF 5,5		
Motor Parameters		
Rated Voltage (star connection) ⁽¹⁾⁽³⁾	[V]	400
Frequency	[Hz]	50
Synchronous Speed	[rpm]	1500
Asynchronous Speed	[rpm]	1424
Rated Current (2)	[A]	12,4
Rated Torque	[Nm]	36,9
Cos φ Power Factor	[]	0,78
Starting Current	[A]	51
Starting Torque	[Nm]	78
Duty Cycle	[%]	60
Starts per Hour	[s/h]	240
Insulation Class	[]	F
Degree of Protection IP	[]	IP21

(1) The motors are standard supplied with star connection (Y), the customer can arrange a delta connection (Δ).

(2) The indicated current values are related to 400V voltage. For current values with delta connection, multiply the values by 1,732.

(3) The standard supply voltage is suitable for 380-400V/220-230V power supplies.

The geared machine includes a fan, 1~220...240V, 50/60Hz.
 Available on request 115V supply voltage.

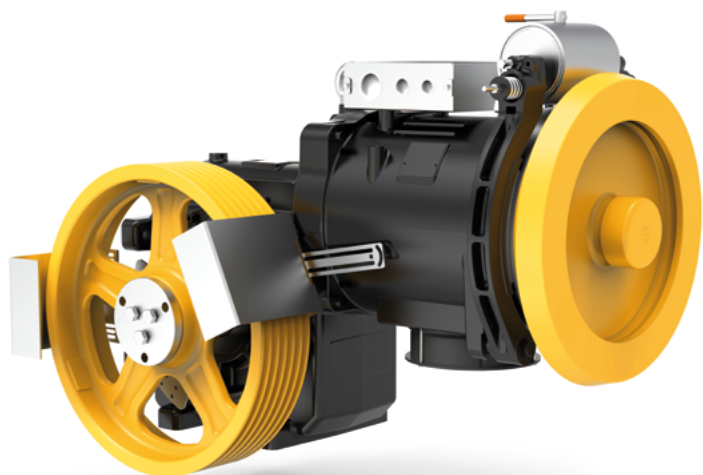

Maximum Static Load	42,2 kN - 4300 kg
Power Range 50 Hz 4 poles VVVF	7,5 ÷ 20 kW
Power Range 50 Hz 4/16 poles	7,5 ÷ 11 kW
Power Range 50 Hz 6 poles VVVF	7,5 ÷ 11 kW
Power Range 50 Hz 6/16 poles	5,1 ÷ 7,5 kW
Power Range 60 Hz 4 poles VVVF	8,2 ÷ 18 kW
Power Range 60 Hz 4/16 poles	8,2 ÷ 12 kW
Power Range 60 Hz 6 poles VVVF	8,2 ÷ 12 kW
Power Range 60 Hz 6/16 poles	5,5 ÷ 8,2 kW
Ratio	1/55; 1/43; 1/35; 2/53; 2/43; 3/41
Geared Weight	450 kg
Oil capacity	9 l
Geared machine Rh o Lh (from motor side)	Image ref. to Lh geared

The geared machine efficiency values are present above each "rated load" table
The motor efficiency values are present in the table "electric motor data"

DIMENSIONS

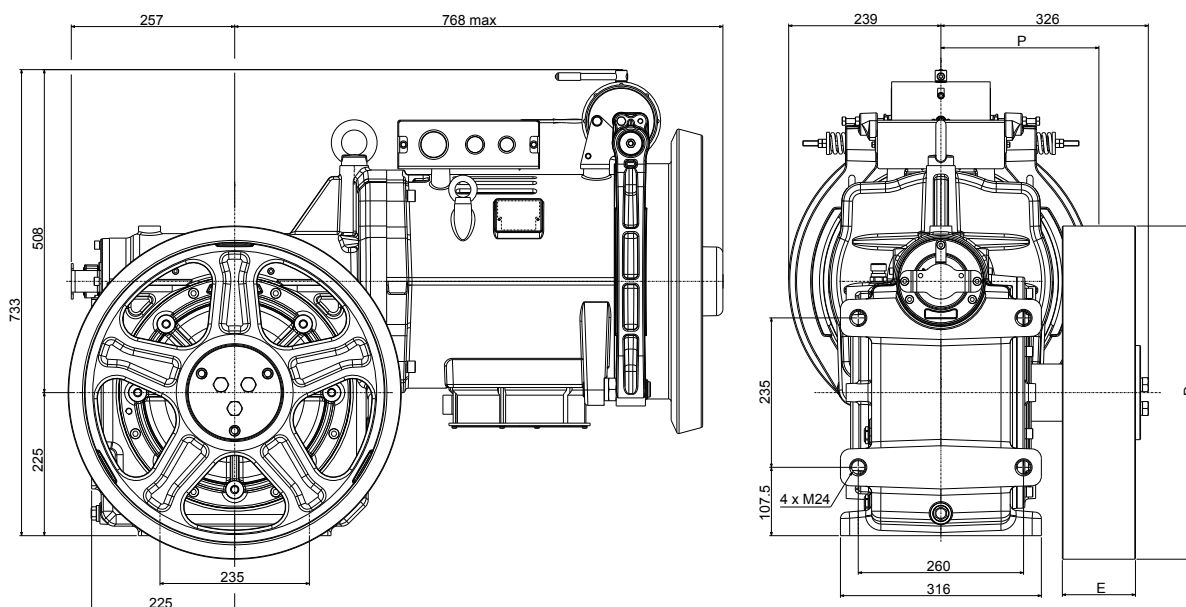

Wrapping System	Traction sheave		Dimension	Load*)	Static Load Direction
	D [mm]	E [mm]			
CSW	450	115	248,5	42,2 - 4300	100% ↑ 100% ← → 100% ↓ 100%
	520				
	560				
	600				
	650				
	700				

*) Max. static load on the slow shaft CSW: Conventional single wrap ESW: Extended single wrap

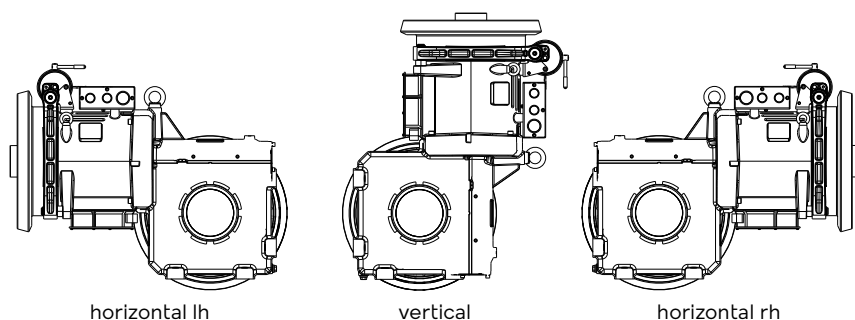

Brake Electromagnet		
[V]	[A]	[W]
24	9,71	233
48	4,85	233
60	3,96	238
80	2,70	216
110	1,83	201
200	1,05	210

		50Hz							60Hz						
		VVVF 1500 rpm 4 Poles AC2 1500/375 rpm 4/16 Poles							VVVF 1800 rpm 4 Poles AC2 1800/450 rpm 4/16 Poles						
		Motor Output [kW]													
		VVVF AC2 7,5	VVVF AC2 9	VVVF AC2 11	VVVF 13,5	VVVF 16,5	VVVF 20		VVVF AC2 8,2	VVVF AC2 10	VVVF AC2 12	VVVF 15	VVVF 18		
R.R.	Traction Sheave Ø	Speed syn.	Max Rated Load						Speed syn.	Max Rated Load					
[i]	[mm]	[m/s]	[kg]	[kg]	[kg]	[kg]	[kg]	[kg]	[m/s]	[kg]	[kg]	[kg]	[kg]	[kg]	
1/55	450	0,64	1250	--	--	--	--	--	0,77	1250	--	--	--	--	
1/55	520	0,74	1200	1220	--	--	--	--	0,89	1085	1160	--	--	--	
1/55	560	0,80	1115	1135	--	--	--	--	0,96	1005	1075	--	--	--	
1/43	450	0,82	1110	1250	--	--	--	--	0,99	1000	1245	1250	--	--	
1/55	600	0,86	1040	1060	--	--	--	--	1,03	940	1005	--	--	--	
1/55	650	0,93	960	975	--	--	--	--	1,11	865	925	--	--	--	
1/43	520	0,95	960	1175	1250	--	--	--	1,14	865	1080	1250	--	--	
1/55	700	1,00	890	905	--	--	--	--	1,20	805	860	--	--	--	
1/35	450	1,01	920	1130	1250	--	--	--	1,21	830	1035	1250	--	--	
1/43	560	1,02	890	1090	1250	--	--	--	1,23	800	1000	1220	1250	--	
1/43	600	1,10	830	1015	1220	--	--	--	1,32	750	935	1140	1165	--	
1/35	520	1,17	800	975	1215	--	--	--	1,40	715	895	1095	1250	--	
1/43	650	1,19	765	940	1125	--	--	--	1,42	690	860	1050	1075	--	
1/35	560	1,26	740	905	1125	1250	--	--	1,51	665	830	1015	1250	--	
1/43	700	1,28	710	870	1045	--	--	--	1,53	640	800	975	1000	--	
2/53	450	1,33	725	885	1100	1250	--	--	1,60	655	815	990	1250	--	
1/35	600	1,35	690	845	1050	1165	--	--	1,62	620	775	945	1165	--	
1/35	650	1,46	640	780	970	1075	--	--	1,75	575	715	875	1075	--	
2/53	520	1,54	625	765	950	1160	--	--	1,85	565	705	860	1090	1095	
1/35	700	1,57	590	725	900	1000	--	--	1,88	530	665	810	1000	--	
2/43	450	1,64	595	725	905	1125	1250	--	1,97	535	665	815	1035	1250	
2/53	560	1,66	580	710	885	1075	--	--	1,99	525	655	795	1010	1015	
2/53	600	1,78	545	665	825	1005	--	--	2,13	490	610	745	945	950	
2/43	520	1,90	515	630	780	970	1200	1220	2,28	465	575	705	895	1085	
2/53	650	1,93	500	610	760	925	--	--	2,31	450	565	685	870	875	
2/43	560	2,05	480	585	725	900	1115	1135	2,45	430	535	655	830	1005	
2/53	700	2,07	465	570	705	860	--	--	2,49	420	525	635	810	815	
2/43	600	2,19	445	545	675	840	1040	1060	2,63	400	500	610	775	940	
2/43	650	2,37	410	500	625	775	960	975	2,85	370	460	565	715	865	
2/43	700	2,56	380	465	580	720	890	905	3,07	345	430	520	665	805	
3/41	450	2,59	385	470	585	730	900	1100	3,10	345	435	530	670	815	
3/41	520	2,99	335	410	505	630	780	950	3,59	300	375	455	580	705	
3/41	560	3,22	310	380	470	585	725	885	3,86	280	345	425	540	655	
3/41	600	3,45	290	355	440	545	675	825	4,14	260	325	395	505	610	
3/41	650	3,74	265	325	405	505	625	760	4,48	240	300	365	465	565	
3/41	700	4,02	245	305	375	470	580	705	4,83	220	275	340	430	520	

		50Hz							60Hz						
		Motor Output [kW]													
		VVVF AC2 7,5	VVVF/ AC2 9	VVVF AC2 11	VVVF 13,5	VVVF 16,5	VVVF 20		VVVF AC2 8,2	VVVF AC2 10	VVVF AC2 12	VVVF 15	VVVF 18		
R.R.	Max Output Torque	Geared Efficiency						Max Output Torque	Geared Efficiency						
[i]	[Nm]							[Nm]							
1/55	1950	0,77	0,78	0,79	0,80	0,81	0,82	1850	0,76	0,77	0,79	0,80	0,81		
1/43	2250	0,78	0,80	0,81	0,82	0,83	0,84	2150	0,78	0,79	0,81	0,82	0,83		
1/35	2150	0,80	0,82	0,83	0,84	0,85	0,86	2150	0,79	0,81	0,82	0,84	0,85		
2/53	1850	0,83	0,85	0,86	0,87	0,88	0,89	1750	0,83	0,84	0,85	0,87	0,88		
2/43	1950	0,84	0,86	0,87	0,88	0,89	0,90	1750	0,83	0,85	0,86	0,88	0,89		
3/41	1850	0,86	0,88	0,89	0,90	0,91	0,92	1900	0,85	0,87	0,88	0,90	0,91		

Rated load values listed in the table include the weight of the ropes.
 To know the theoretical load, subtract the weight of the ropes.
 Position Of The Geared = Top Counterweight = 50% Plant efficiency = 0,80

		50Hz						60Hz						
		VVVF 1000 rpm 6 Poles AC2 1000/375 rpm 6/16 Poles						VVVF 1200 rpm 6 Poles AC2 1200/450 rpm 6/16 Poles						
		Motor Output [kW]												
R.R.	Traction Sheave Ø	Speed syn.	VVVF AC2 5.0	VVVF AC2 7.5	VVVF 9	VVVF 11	VVVF 13.5	Speed syn.	VVVF AC2 5.5	VVVF AC2 8.2	VVVF 10	VVVF 12	VVVF 15	
[i]	[mm]	[m/s]	Max Rated Load					[m/s]	Max Rated Load					
			[kg]	[kg]	[kg]	[kg]	[kg]		[kg]	[kg]	[kg]	[kg]	[kg]	
1/55	450	0,43	1250	--	--	--	--	0,51	1250	--	--	--	--	
1/55	520	0,50	1200	1250	--	--	--	0,59	1095	1250	--	--	--	
1/55	560	0,53	1115	1250	--	--	--	0,64	1015	1250	--	--	--	
1/43	450	0,55	1110	1250	--	--	--	0,66	1010	1250	--	--	--	
1/55	600	0,57	1040	1165	--	--	--	0,69	945	1165	--	--	--	
1/55	650	0,62	960	1075	--	--	--	0,74	875	1075	--	--	--	
1/43	520	0,63	960	1250	--	--	--	0,76	875	1250	--	--	--	
1/55	700	0,67	890	1000	--	--	--	0,80	810	1000	--	--	--	
1/35	450	0,67	925	1250	--	--	--	0,81	840	1250	--	--	--	
1/43	560	0,68	890	1250	--	--	--	0,82	810	1250	--	--	--	
1/43	600	0,73	835	1250	--	--	--	0,88	755	1175	1250	--	--	
1/35	520	0,78	800	1240	1250	--	--	0,93	725	1125	1250	--	--	
1/43	650	0,79	770	1175	--	--	--	0,95	700	1085	1175	--	--	
1/35	560	0,84	740	1155	1250	--	--	1,01	675	1045	1250	--	--	
1/43	700	0,85	715	1095	--	--	--	1,02	650	1005	1095	--	--	
2/53	450	0,89	725	1125	1250	--	--	1,07	660	1020	1250	--	--	
1/35	600	0,90	690	1075	1250	--	--	1,08	630	975	1205	1250	--	
1/35	650	0,97	640	995	1150	--	--	1,17	580	900	1115	1150	--	
2/53	520	1,03	630	975	1180	1250	--	1,23	570	880	1090	1250	--	
1/35	700	1,05	595	920	1070	--	--	1,26	540	835	1035	1070	--	
2/43	450	1,10	595	920	1120	1250	--	1,32	540	840	1035	1250	--	
2/53	560	1,11	585	900	1095	1160	--	1,33	530	820	1010	1160	--	
2/53	600	1,19	545	840	1025	1085	--	1,42	495	765	945	1085	--	
2/43	520	1,27	515	800	970	1200	1250	1,52	470	725	895	1085	1250	
2/53	650	1,28	500	780	945	1000	--	1,54	455	705	870	1000	--	
2/43	560	1,36	475	740	900	1110	1250	1,64	435	675	830	1010	1250	
2/53	700	1,38	465	720	875	930	--	1,66	420	655	810	930	--	
2/43	600	1,46	445	690	840	1035	1220	1,75	405	630	775	940	1190	
2/43	650	1,58	410	640	775	960	1125	1,90	375	580	715	870	1095	
2/43	700	1,70	380	590	720	885	1045	2,05	345	540	665	805	1020	
3/41	450	1,72	385	600	730	900	1110	2,07	350	545	675	815	1030	
3/41	520	1,99	335	520	630	780	965	2,39	305	470	580	705	890	
3/41	560	2,15	310	480	585	725	895	2,57	280	435	540	655	825	
3/41	600	2,30	290	450	545	670	830	2,76	265	410	505	610	770	
3/41	650	2,49	265	415	505	620	770	2,99	245	375	465	565	715	
3/41	700	2,68	250	385	470	575	710	3,22	225	350	430	525	660	

		50Hz						60Hz						
		Motor Output [kW]												
		VVVF AC2 5.0	VVVF AC2 7.5	VVVF 9	VVVF 11	VVVF 13.5		VVVF AC2 5.5	VVVF AC2 8.2	VVVF 10	VVVF 12	VVVF 15		
R.R.	Max Output Torque	Geared Efficiency					Max Output Torque	Geared Efficiency						
[i]	[Nm]						[Nm]							
1/55	2150	0,77	0,79	0,80	0,81	0,82	2150	0,76	0,79	0,80	0,81	0,81		
1/43	2350	0,79	0,81	0,82	0,83	0,84	2350	0,78	0,81	0,82	0,83	0,84		
1/35	2300	0,80	0,83	0,84	0,85	0,86	2300	0,80	0,83	0,84	0,85	0,86		
2/53	2000	0,83	0,86	0,87	0,88	0,89	2000	0,82	0,85	0,87	0,87	0,88		
2/43	2250	0,84	0,87	0,88	0,89	0,90	2250	0,84	0,87	0,88	0,89	0,90		
3/41	2000	0,86	0,89	0,90	0,91	0,92	2000	0,86	0,89	0,90	0,91	0,92		

		50Hz								
		VVVF 1500 rpm 4 Poles AC2 1500/375 rpm 4/16 Poles								
		Asynchronous Rated Power [kW]								
		VVVF 7,5	VVVF 9,2	VVVF 11	VVVF 13,5	VVVF 16,5	VVVF 20	AC2 7,5	AC2 9	AC2 11
		Motor Parameters								
Rated Voltage (star connection) ^{(1) (3)}	[V]	400	400	400	400	400	400	400	400	400
Frequency	[Hz]	50	50	50	50	50	50	50	50	50
Synchronous Speed	[rpm]	1500	1500	1500	1500	1500	1500	1500/375	1500/375	1500/375
Asynchronous Speed	[rpm]	1458	1460	1457	1476	1475	1477	1370/300	1370/300	1370/300
Rated Current ⁽²⁾	[A]	17,3	21,2	24,1	27,4	34,1	40,6	22/13	25/15	29/17
Rated Torque	[Nm]	50	63	72	87	107	129	52	63	77
Cos ϕ Power Factor	[]	0,72	0,7	0,76	0,84	0,82	0,82	0,76	0,75	0,75
Starting Current	[A]	110	133	157	168	230	304	72	102	125
Starting Torque	[Nm]	117	145	163	126	182	270	125/78	150/93	183/114
Duty Cycle	[%]	60	60	60	60	60	60	30+10	30+10	30+10
Starts per Hour	[s/h]	240	240	240	240	240	240	180	180	180
Insulation Class	[]	F	F	F	F	F	F	F	F	F
Degree of Protection IP	[]	IP21	IP21	IP21	IP21	IP21	IP21	IP21	IP21	IP21

(1) The motors are standard supplied with star connection (Y), the customer can arrange a delta connection (Δ).

(2) The indicated current values are related to 400V voltage. For current values with delta connection, multiply the values by 1,732.

(3) The standard supply voltage is suitable for 380-400V/220-230V power supplies.

The geared machine includes a fan, 1~220...240V, 50/60Hz.

Available on request 115V supply voltage.

		60Hz								
		VVVF 1800 rpm 4 Poles AC2 1800/450 rpm 4/16 Poles								
		Asynchronous Rated Power [kW]								
		VVVF 8,2	VVVF 10	VVVF 12	VVVF 15	VVVF 18	AC2 8,2	AC2 10	AC2 12	
		Motor Parameters								
Rated Voltage (star connection) ^{(1) (3)}	[V]	400	400	400	400	400	400	400	400	400
Frequency	[Hz]	60	60	60	60	60	60	60	60	60
Synchronous Speed	[rpm]	1800	1800	1800	1800	1800	1800/450	1800/450	1800/450	
Asynchronous Speed	[rpm]	1700	1710	1748	1774	1778	1670/362	1664/373	1645/360	
Rated Current ⁽²⁾	[A]	19,2	21,5	25,5	27	35	19,2/15	22/18,4	31/18	
Rated Torque	[Nm]	46	56	65	81	97	47	57	68	
Cos ϕ Power Factor	[]	0,75	0,76	0,76	0,84	0,84	0,76	0,8	0,75	
Starting Current	[A]	110	131	150	128	232	70	105	120	
Starting Torque	[Nm]	105	125	163	160	164	110	147	159	
Duty Cycle	[%]	60	60	60	60	60	30+10	30+10	30+10	
Starts per Hour	[s/h]	240	240	240	240	240	180	180	180	
Insulation Class	[]	F	F	F	F	F	F	F	F	
Degree of Protection IP	[]	IP21	IP21	IP21	IP21	IP21	IP21	IP21	IP21	

(1) The motors are standard supplied with star connection (Y), the customer can arrange a delta connection (Δ).

(2) The indicated current values are related to 400V voltage. For current values with delta connection, multiply the values by 1,732.

(3) The standard supply voltage is suitable for 380-400V/220-230V power supplies.

The geared machine includes a fan, 1~220...240V, 50/60Hz.

Available on request 115V supply voltage.

50Hz

VVVF 1000 rpm 6 Poles
AC2 1000/375 rpm 6/16 Poles

Asynchronous Rated Power [kW]

VVVF 5	VVVF 7,5	VVVF 9	VVVF 11	VVVF 13,5	AC2 5	AC2 7,5
Motor Parameters						
400	400	400	400	400	400	400
50	50	50	50	50	50	50
1000	1000	1000	1000	1000	1000/375	1000/375
970	972	978	980	983	920/292	910/300
14,8	21,2	21,5	25,8	31,3	18/14	24/20
49	74	87	106	131	52	76
0,6	0,61	0,74	0,73	0,73	0,65	0,66
79	128	102	125	168	52	56
135	210	98	131	197	105	125
60	60	60	60	60	30+10	30+10
240	240	240	240	240	180	180
F	F	F	F	F	F	F
IP21	IP21	IP21	IP21	IP21	IP21	IP21

60Hz

VVVF 1200 rpm 6 Poles
AC2 1200/450 rpm 6/16 Poles

Asynchronous Rated Power [kW]

VVVF 5,5	VVVF 8,2	VVVF 10	VVVF 12	VVVF 15	AC2 5,5	AC2 8,2
Motor Parameters						
400	400	400	400	400	400	400
60	60	60	60	60	60	60
1200	1200	1200	1200	1200	1200/450	1200/450
1148	1152	1175	1173	1176	1090/360	1095/363
15	21	22	25,8	33	22/18	27/22
46	68	81	98	122	46	68
0,7	0,67	0,72	0,71	0,72	0,61	0,66
72	76	79	106	119	57	62
95	112,5	121	146	175	95	113
60	60	60	60	60	30+10	30+10
240	240	240	240	240	180	180
F	F	F	F	F	F	F
IP21	IP21	IP21	IP21	IP21	IP21	IP21

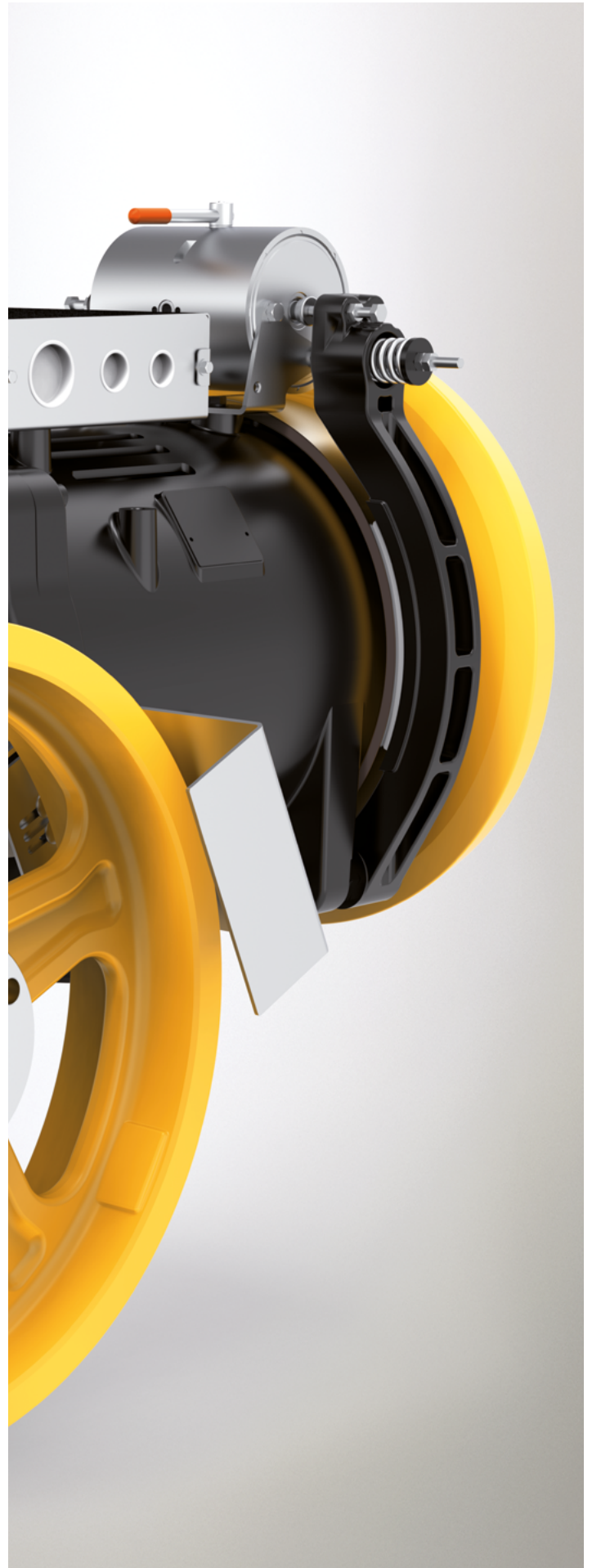

Wrapping System	Traction sheave		Max n° Grooves x D	Grooves Pitch
	D [mm]	E [mm]	n° x mm	l [mm]
CSW	450	115	7xD8	14
	450	115	6xD9	17
	450	115	6xD10	17
	450	115	6xD11	17
	520	115	7xD8	14
	520	115	6xD9	17
	520	115	6xD10	17
	520	115	6xD11	17
	520	115	5xD12	19
	520	115	5xD13	19
	560	115	7xD8	14
	560	115	6xD9	17
	560	115	6xD10	17
	560	115	6xD11	17
	560	115	5xD12	19
	560	115	5xD13	19
	560	115	4xD14	22
	600	115	7xD8	14
	600	115	6xD9	17
	600	115	6xD10	17
	600	115	6xD11	17
	600	115	5xD12	19
	600	115	5xD13	19
	600	115	4xD14	22
	600	115	4xD15	22
	650	115	7xD8	14
	650	115	6xD9	17
	650	115	6xD10	17
	650	115	6xD11	17
	650	115	5xD12	19
	650	115	5xD13	19
	650	115	4xD14	22
	650	115	4xD15	22
	650	115	4xD16	22
	700	115	7xD8	14
	700	115	6xD9	17
	700	115	6xD10	17
	700	115	6xD11	17
	700	115	5xD12	19
	700	115	5xD13	19
700	115	4xD14	22	
700	115	4xD15	22	
700	115	4xD16	22	

VCI

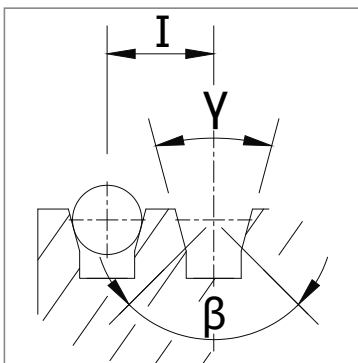

V grooves with undercut

UCI

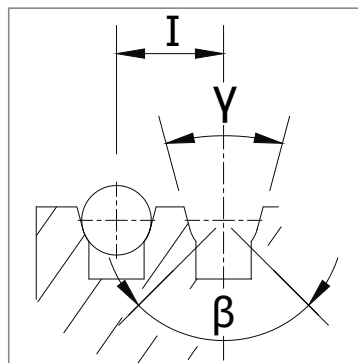

U grooves with undercut

γ = groove angle
 β = undercut angle
 I = grooves pitch

BEDPLATE SH160 | TOP MACHINE WITHOUT DIVERTING PULLEY FOR CSW WRAPPING

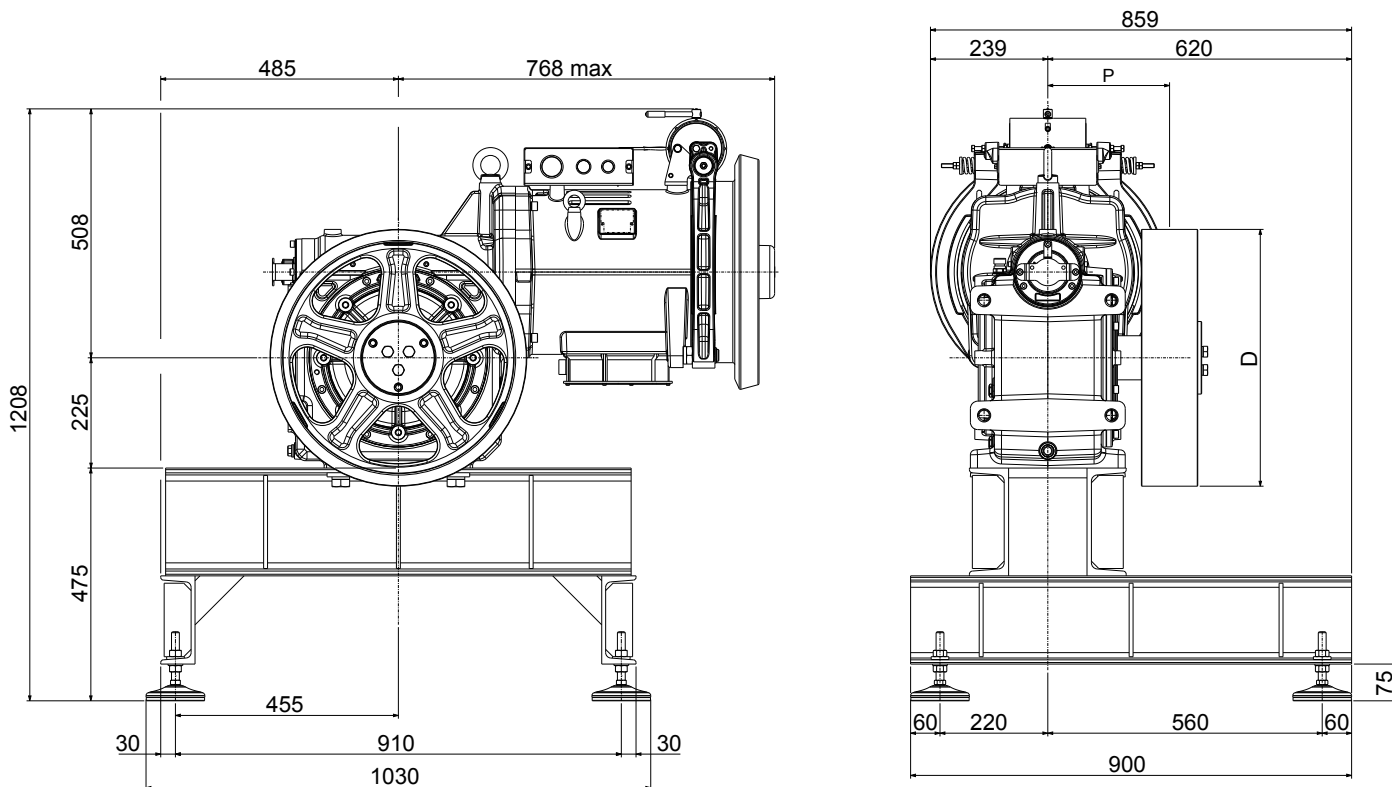

XTE5706 (D 450-700) (vibration dampers included)
 Weight of machine bedplate: 108 kg (bedplate + vibration dampers)

VIBRATIONS DAMPER SET UP

Damper code	Dimension
	[mm]
TAI0111	D.120x32

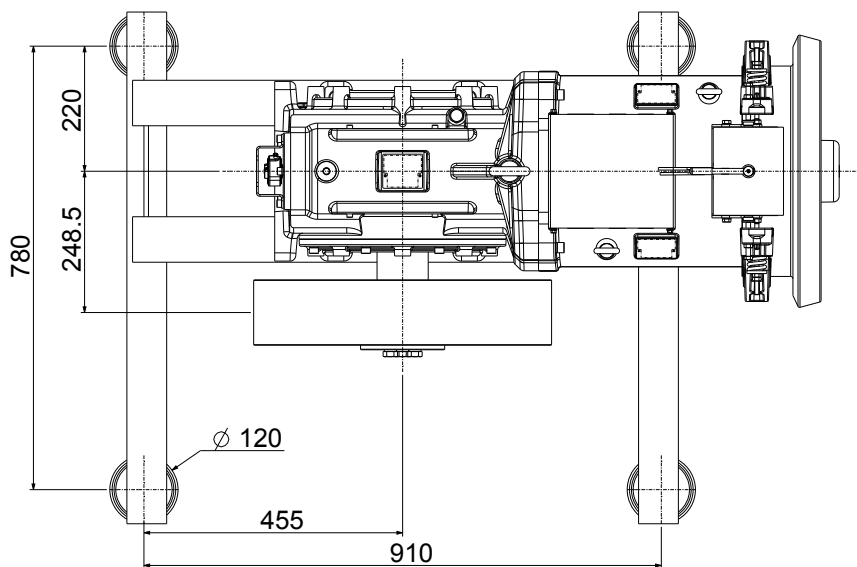

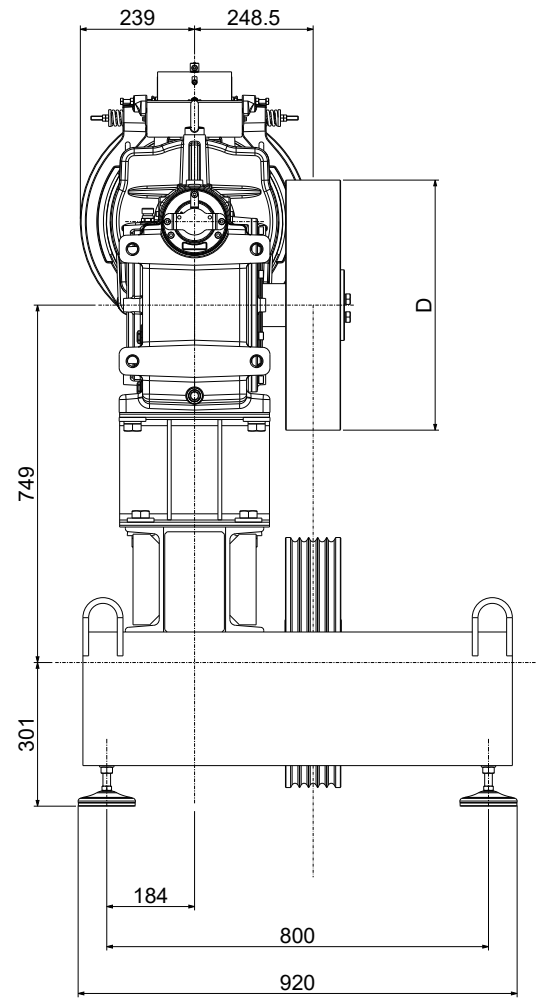
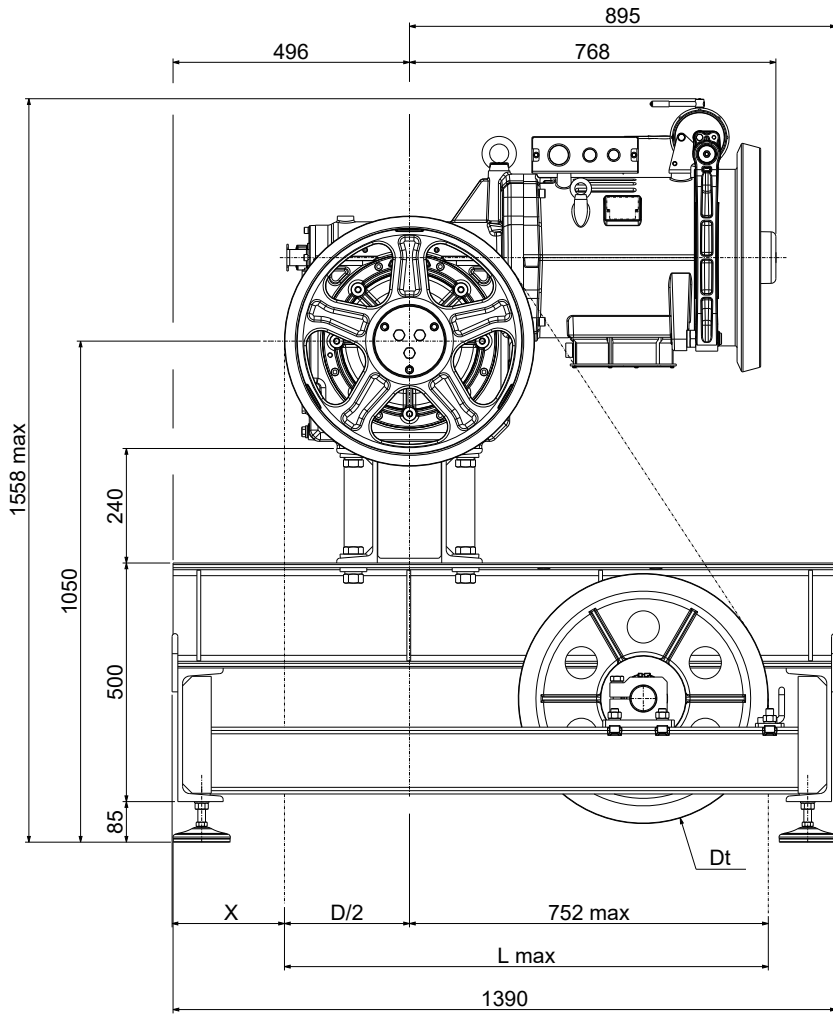

XTE5708 (Dt 400-450-520) (vibration dampers included)
 Weight of machine bedplate: 293 kg. (bedplate + diverting pulley + vibration dampers)

VIBRATIONS DAMPER SET UP

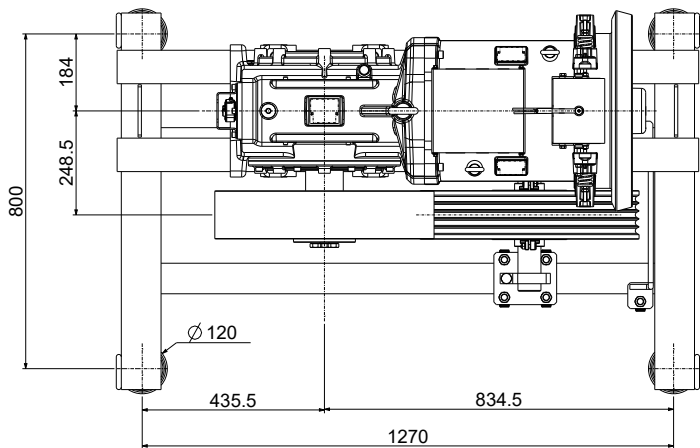

Traction Sheave	X	L Max
D [mm]	[mm]	[mm]
450	270	975
520	235	1010
560	215	1030
600	195	1050
650	170	1075
700	145	1100

Damper code	Dimension
	[mm]
TAI0111	D.120x32

BEDPLATE SH160 LS | BOTTOM DRIVE MACHINE WITH CSW WRAPPING

(Ropes upwards)

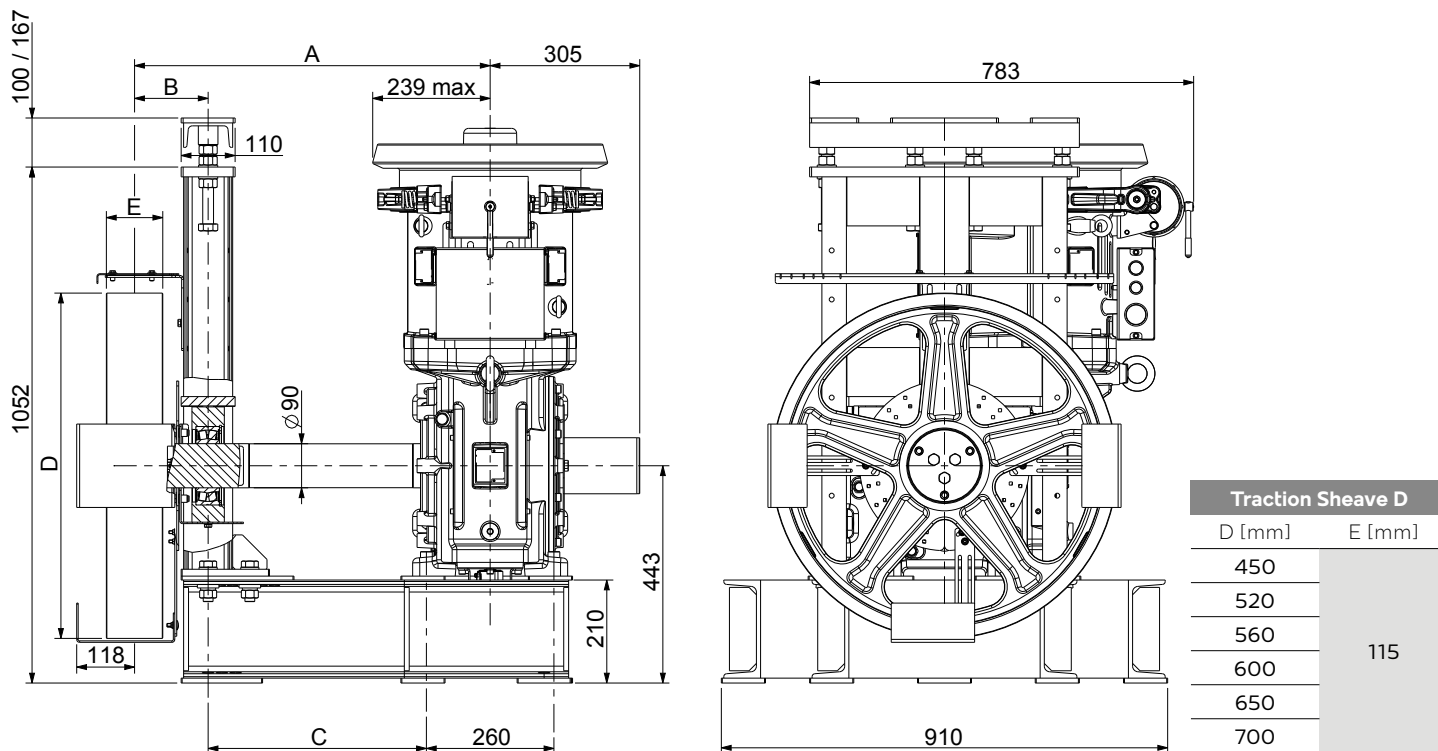

INSTALLATION POSITION

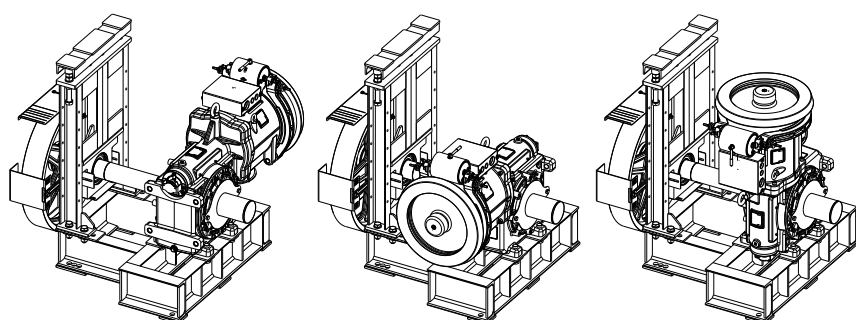

Right hand Machine Left hand Machine Vertical Machine

Quote "A"	Quote "B"	Quote "C"	Static load	Code*
[mm]	[mm]	[mm]	[kg]	
500	150	220	4300	XTE8010
	175	195	3700	XTE8010
	200	170	3200	XTE8010
600	150	320	4300	XTE8009
	175	295	3700	XTE8009
	200	270	3200	XTE8009
725	150	445	4300	XTE6405
	175	420	3700	XTE6405
	200	395	3200	XTE6405

*Always supplied with the machine.

DIVERTING PULLEYS AND GROOVES NUMBER x ROPES DIAMETER

Diverting Pulley		Max n°Grooves x D	Grooves Pitch
Dt [mm]	E [mm]	n° x mm	l [mm]
400	116	7xD8	14
450	116	6xD11	17
520	116	5xD13	19

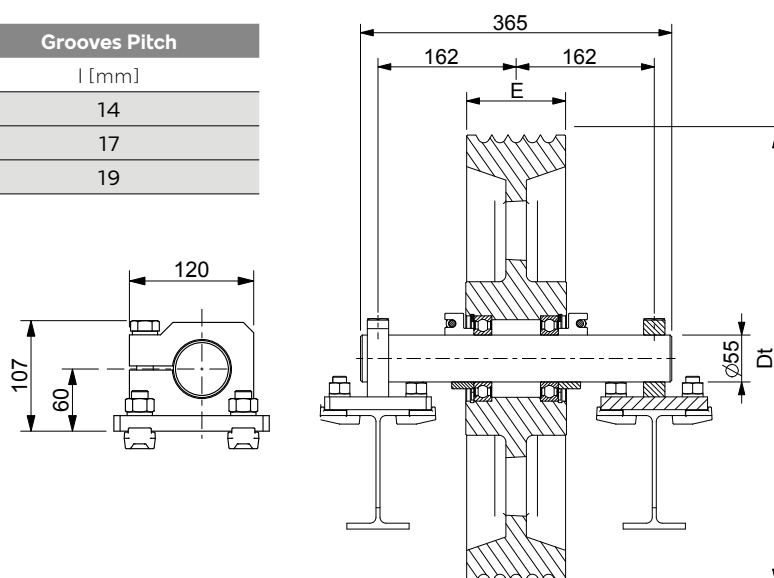

SH160T

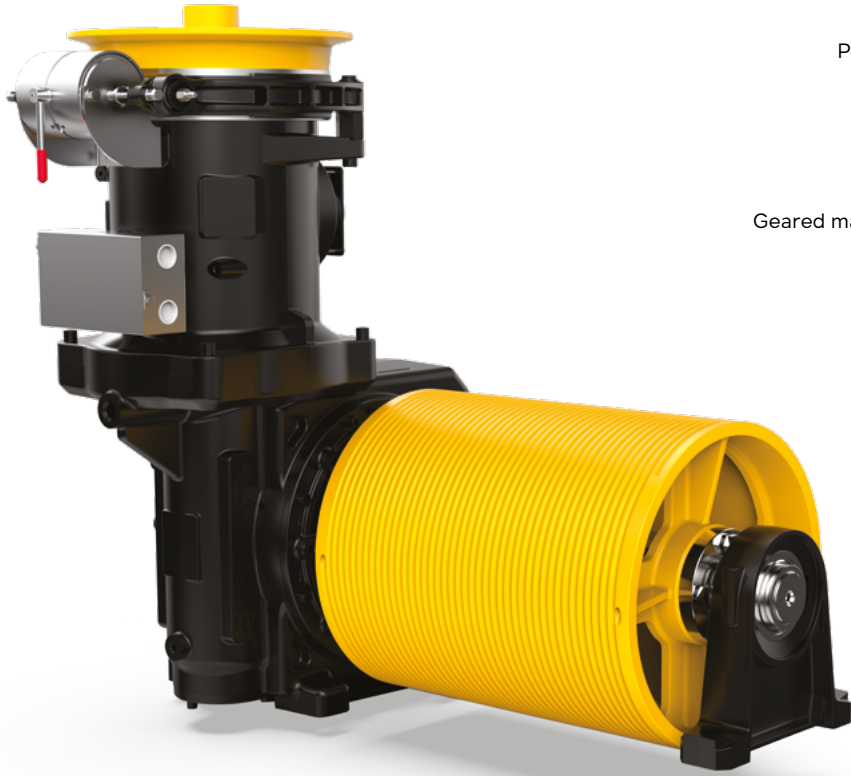

Power Range 50 Hz 4 poles VVVF **9 - 11 kW**

Ratio **1/43**

Speed synchronous **0,63 m/s**

Geared Weight **550 kg**

Oil capacity **9 l**

Geared machine Rh o Lh (from motor side) **Image ref. to Lh geared**

DIMENSIONS

Brake Electromagnet		
[V]	[A]	[W]
24	9,71	233
48	4,85	233
60	3,96	238
80	2,70	216
110	1,83	201
200	1,05	210

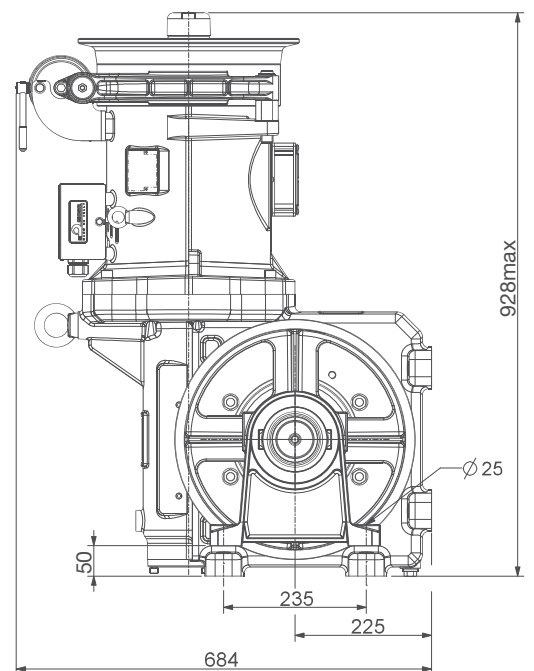
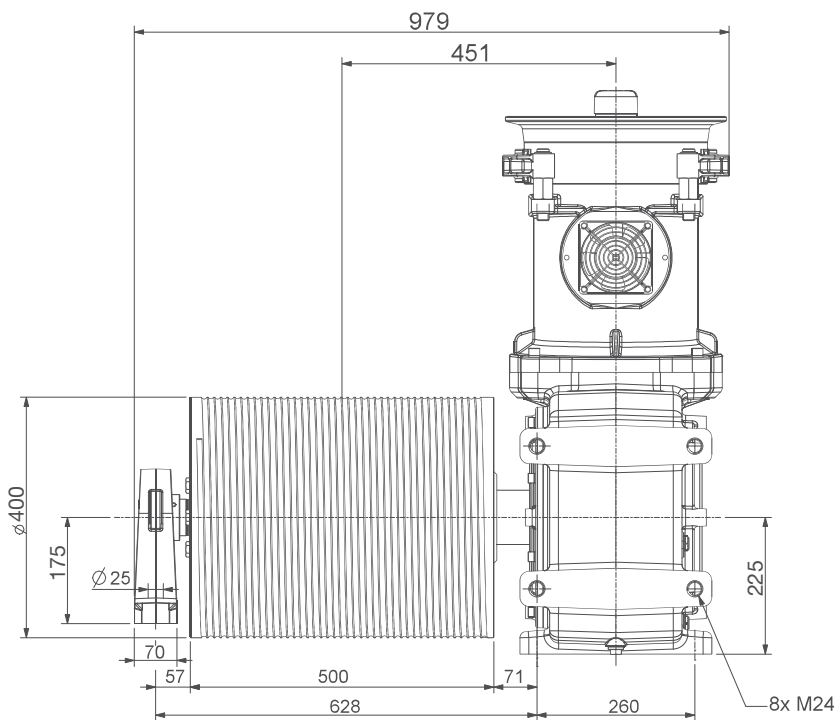

DUTY TABLE

Roping 1:1

		50Hz						
		VVVF 1500 rpm 4 Poles		Motor Output [kW]				
		VVVF 9		VVVF 11				
R.R.	Traction Drum Ø	Installation frequency	Max Rated Load		Max cabin load	Ropes Nr x diameter Ø	Max travel with 2 parallel ropes	
[i]	[mm]	[Hz]	[kg]	[kg]	[kg]	[mm]	[m]	
1/43	400	43	225	--	500	2 x Ø8 (*)	29	
						2 x Ø9 (*)	26	
						2 x Ø10	23	
		43	320	--	400	400	2 x Ø8 (*)	29
							2 x Ø9 (*)	26
							2 x Ø10	23
		43	--	400	400	500	2 x Ø9 (*)	26
							2 x Ø10 (*)	23

Rated load values listed in the table include the weight of the ropes.

To know the theoretical load, subtract the weight of the ropes.

Position Of The Geared = Top Plant efficiency = 0,80

(*) high tensile strenght ropes

ELECTRIC MOTOR DATA

		50Hz			
		VVVF 1500 rpm 4 Poles		Asynchronous Rated Power [kW]	
		VVVF 9		VVVF 11	
		Motor Parameters			
Rated Voltage (star connection) ⁽¹⁾⁽³⁾	[V]	400		400	
Frequency	[Hz]	50		50	
Synchronous Speed	[rpm]	1500		1500	
Asynchronous Speed	[rpm]	1471		1470	
Rated Current ⁽²⁾	[A]	19		22	
Rated Torque	[Nm]	58		72	
Cos φ Power Factor	[]	0,8		0,81	
Starting Current	[A]	87		94	
Starting Torque	[Nm]	80		86	
Duty Cycle	[%]	60		60	
Starts per Hour	[s/h]	240		240	
Insulation Class	[]	F		F	
Degree of Protection IP	[]	IP21		IP21	

(1) The motors are standard supplied with star connection (Y), the customer can arrange a delta connection (Δ).

(2) The indicated current values are related to 400V voltage. For current values with delta connection, multiply the values by 1,732.

(3) The standard supply voltage is suitable for 380-400V/220-230V power supplies.

The geared machine includes a fan, 1~220...240V, 50/60Hz.

Available on request 115V supply voltage.

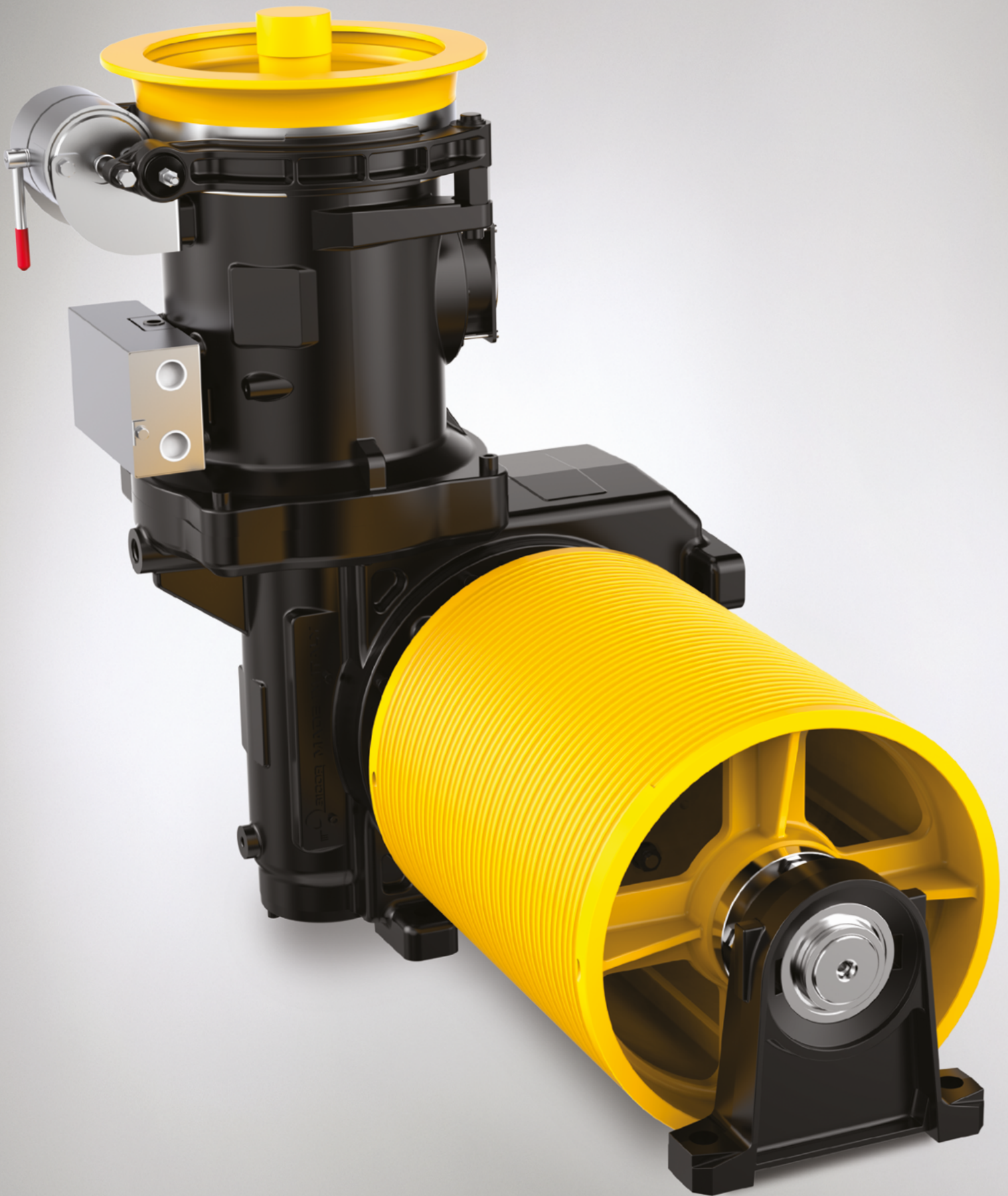

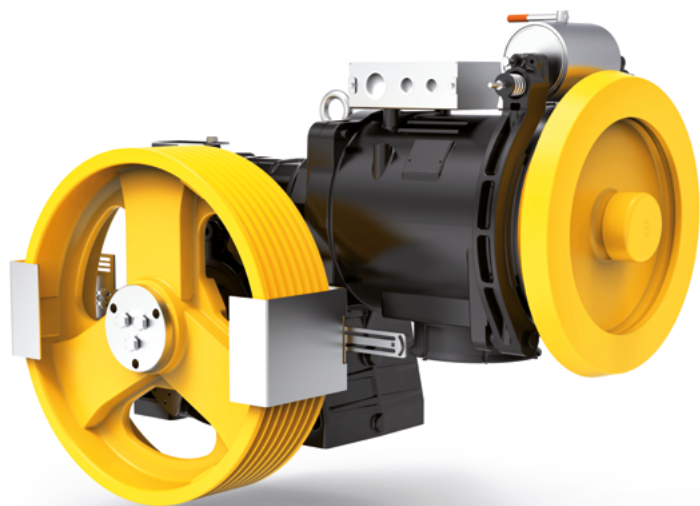

Max. Static Load **51 kN - 5200 kg**
 Power Range 50 Hz 4 poles VVVF **7,5 ÷ 30 kW**
 Power Range 50 Hz 4/16 poles **7,5 ÷ 16,5 kW**
 Power Range 50 Hz 6 poles VVVF **4,2 ÷ 20 kW**
 Power Range 50 Hz 6/16 poles **4,2 ÷ 9 kW**
 Power Range 60 Hz 4 poles VVVF **8,2 ÷ 33 kW**
 Power Range 60 Hz 4/16 poles **8,2 ÷ 18 kW**
 Power Range 60 Hz 6 poles VVVF **4,7 ÷ 22 kW**
 Power Range 60 Hz 6/16 poles **4,7 ÷ 10 kW**
 Ratio **1/40; 1/51; 1/62; 2/59; 3/47**
 Geared Weight **620 kg**
 Oil capacity **11,5 l**

Geared machine Rh o Lh (from motor side) **Image ref. to Lh geared**

*The geared machine efficiency values are present above each "rated load" table
 The motor efficiency values are present in the table "electric motor data"*

DIMENSIONS

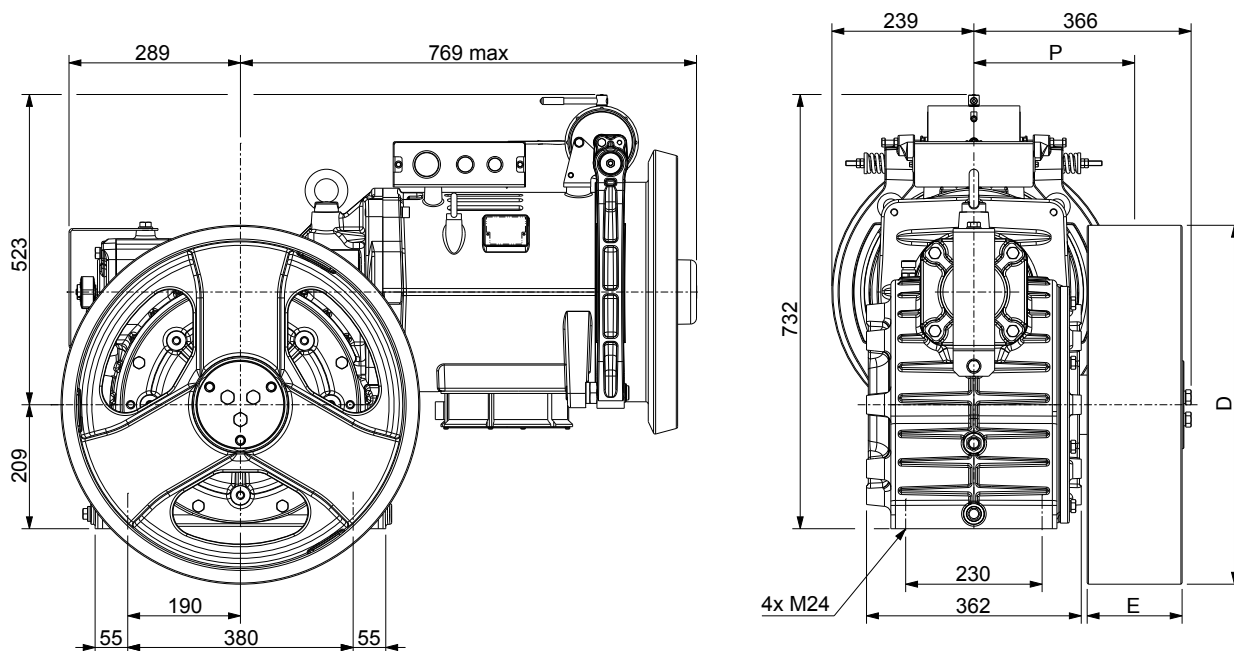

Wrapping System	Traction sheave		Dimension	Load*)	Static Load Direction
	D [mm]	E [mm]			
ESW/CSW	520	176	279	51 - 5200	
	600				
CSW	650	160	271	51 - 5200	
	690				
	750				

*) Max. static load on the slow shaft CSW: Conventional single wrap ESW: Extended single wrap (patented)

Brake Electromagnet		
[V]	[A]	[W]
24	9,71	233
48	4,85	233
60	3,95	237
80	2,70	215
110	1,83	200
200	1,05	210

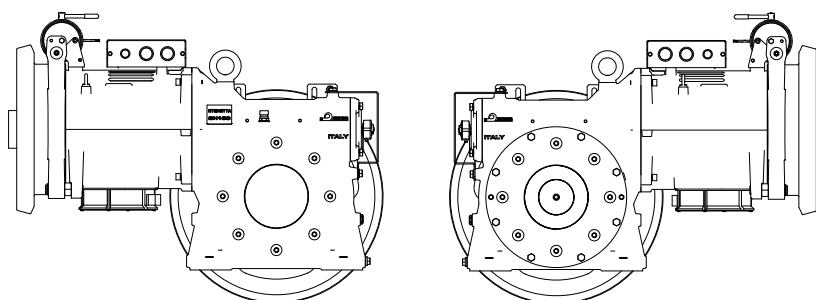

horizontal lh

horizontal rh

		50Hz											60Hz											
		VVVF 1500 rpm 4 Poles AC2 1500/375 rpm 4/16 Poles											VVVF 1800 rpm 4 Poles AC2 1800/450 rpm 4/16 Poles											
		Motor Output [kW]																						
Pa	Pq	Wrapping system	R.R.	Trac. Sheave Ø	Speed syn.	Max Rated Load									Speed syn.	Max Rated Load								
						AC2 7,5	VVVF AC2 9,2	VVVF AC2 11	VVVF AC2 13,5	VVVF AC2 16,5	VVVF 20	VVVF 25	VVVF 30	AC2 8,2		VVVF AC2 10	VVVF AC2 12	VVVF AC2 15	VVVF AC2 18	VVVF 22	VVVF 27	VVVF 33		
CSW	ESW	[i]	[mm]	[m/s]	[kg]	[kg]	[kg]	[kg]	[kg]	[kg]	[kg]	[kg]	[kg]	[m/s]	[kg]	[kg]	[kg]	[kg]	[kg]	[kg]	[kg]	[kg]		
X	X	1/62	520	0,66	1310	1500	--	--	--	--	--	--	0,79	1175	1470	1500	--	--	--	--	--			
X	--	1/62	600	0,76	1135	1425	1500	--	--	--	--	--	0,91	1020	1275	1500	--	--	--	--	--			
X	X	1/51	520	0,80	1120	1405	1500	--	--	--	--	--	0,96	1005	1255	1500	--	--	--	--	--			
X	--	1/62	650	0,82	1045	1315	1500	--	--	--	--	--	0,99	940	1175	1435	1500	--	--	--	--			
X	--	1/62	690	0,87	985	1240	1455	--	--	--	--	--	1,05	885	1105	1355	1455	--	--	--	--			
X	--	1/51	600	0,92	970	1215	1480	1500	--	--	--	--	1,11	870	1090	1330	1500	--	--	--	--			
X	--	1/62	750	0,95	905	1140	1335	--	--	--	--	--	1,14	815	1020	1245	1335	--	--	--	--			
X	--	1/51	650	1,00	895	1125	1365	1500	--	--	--	--	1,20	805	1005	1230	1500	--	--	--	--			
X	X	1/40	520	1,02	900	1130	1370	1500	--	--	--	--	1,23	805	1010	1235	1500	--	--	--	--			
X	--	1/51	690	1,06	845	1060	1285	1415	--	--	--	--	1,28	755	945	1155	1415	--	--	--	--			
X	--	1/51	750	1,15	775	975	1180	1300	--	--	--	--	1,39	695	870	1065	1300	--	--	--	--			
X	--	1/40	600	1,18	780	980	1190	1480	1500	--	--	--	1,41	700	875	1070	1360	1500	--	--	--			
X	--	1/40	650	1,28	720	900	1095	1365	1500	--	--	--	1,53	645	805	985	1255	1500	--	--	--			
X	--	1/40	690	1,35	675	850	1035	1290	1470	--	--	--	1,63	605	760	930	1185	1440	1470	--	--			
X	X	2/59	520	1,38	685	860	1045	1300	1500	--	--	--	1,66	615	770	940	1200	1455	1500	--	--			
X	--	1/40	750	1,47	620	780	950	1185	1350	--	--	--	1,77	560	700	855	1090	1325	1350	--	--			
X	--	2/59	600	1,60	595	745	905	1130	1395	1500	--	--	1,92	530	665	815	1040	1260	1500	--	--			
X	--	2/59	650	1,73	550	685	835	1040	1290	1500	--	--	2,08	490	615	750	960	1165	1440	1500	--			
X	--	2/59	690	1,84	515	645	785	980	1215	1485	--	--	2,20	465	580	710	900	1095	1355	1485	--			
X	--	2/59	750	2,00	475	595	725	900	1115	1365	1370	--	2,40	425	530	650	830	1010	1245	1370	--			
X	X	3/47	520	2,61	380	475	575	720	890	1085	1370	1500	3,13	340	425	520	660	800	990	1225	1500			
X	--	3/47	600	3,01	325	410	500	620	770	940	1185	1435	3,61	295	365	450	570	695	860	1065	1310			
X	--	3/47	650	3,26	300	380	460	575	710	870	1095	1320	3,91	270	340	415	530	640	790	980	1210			
X	--	3/47	690	3,46	285	355	435	540	670	820	1030	1245	4,15	255	320	390	495	605	745	925	1140			
X	--	3/47	750	3,76	260	330	400	495	615	755	950	1145	4,51	235	295	360	455	555	685	850	1045			

		50Hz											60Hz										
		Motor Output [kW]											Motor Output [kW]										
R.R.	Max Output Torque	Geared Efficiency									Max Output Torque	Geared Efficiency											
		AC2 7,5	VVVF AC2 9,2	VVVF AC2 11	VVVF AC2 13,5	VVVF AC2 16,5	VVVF 20	VVVF 25	VVVF 30	AC2 8,2		VVVF AC2 10	VVVF AC2 12	VVVF AC2 15	VVVF AC2 18	VVVF 22	VVVF 27	VVVF 33					
[i]	[Nm]										[Nm]												
1/62	3080	0,74	0,76	0,77	0,78	0,79	0,80	0,80	0,81	3080	0,73	0,75	0,76	0,78	0,79	0,79	0,80	0,81					
1/51	3000	0,77	0,79	0,80	0,81	0,82	0,83	0,84	0,84	3000	0,76	0,78	0,79	0,81	0,82	0,83	0,83	0,84					
1/40	3110	0,79	0,81	0,82	0,83	0,84	0,85	0,86	0,86	3110	0,78	0,80	0,81	0,83	0,84	0,85	0,85	0,86					
2/59	3150	0,82	0,84	0,85	0,86	0,87	0,88	0,89	0,89	3150	0,81	0,83	0,84	0,86	0,87	0,88	0,88	0,89					
3/47	2860	0,85	0,87	0,88	0,90	0,91	0,91	0,92	0,93	2860	0,84	0,86	0,87	0,89	0,90	0,91	0,92	0,92					

Rated load values listed in the table include the weight of the ropes.
 To know the theoretical load, subtract the weight of the ropes.
 Position Of The Geared = Top Counterweight = 50% Plant efficiency = 0,80

50Hz									60Hz								
VVVF 1000 rpm 6 Poles AC2 1000/375 rpm 6/16 Poles									VVVF 1200 rpm 6 Poles AC2 1200/450 rpm 6/16 Poles								
Motor Output [kW]																	
	VVVF AC2 4,2	VVVF AC2 5	VVVF AC2 7,5	VVVF AC2 9	VVVF 11	VVVF 13,5	VVVF 16,5	VVVF 20		VVVF AC2 4,7	VVVF AC2 5,5	VVVF AC2 8,2	VVVF AC2 10	VVVF 12	VVVF 15	VVVF 18	VVVF 22
Speed syn.	Max Rated Load								Speed syn.	Max Rated Load							
[m/s]	[kg]	[kg]	[kg]	[kg]	[kg]	[kg]	[kg]	[kg]	[m/s]	[kg]	[kg]	[kg]	[kg]	[kg]	[kg]	[kg]	[kg]
0,44	1065	1300	1500	--	--	--	--	--	0,53	980	1175	1500	--	--	--	--	--
0,51	925	1125	1500	--	--	--	--	--	0,61	850	1020	1500	--	--	--	--	--
0,53	910	1110	1500	--	--	--	--	--	0,64	840	1005	1500	--	--	--	--	--
0,55	850	1040	1500	--	--	--	--	--	0,66	785	940	1470	1500	--	--	--	--
0,58	800	980	1500	--	--	--	--	--	0,70	740	885	1385	1500	--	--	--	--
0,62	790	965	1500	--	--	--	--	--	0,74	725	870	1360	1500	--	--	--	--
0,63	740	900	1410	1500	--	--	--	--	0,76	680	815	1275	1500	--	--	--	--
0,67	730	890	1390	1500	--	--	--	--	0,80	670	805	1255	1500	--	--	--	--
0,68	735	895	1400	1500	--	--	--	--	0,82	675	810	1265	1500	--	--	--	--
0,71	685	840	1310	1500	--	--	--	--	0,85	630	755	1185	1465	1500	--	--	--
0,77	630	770	1205	1465	1500	--	--	--	0,92	580	695	1090	1350	1500	--	--	--
0,79	635	775	1215	1475	1500	--	--	--	0,94	585	700	1095	1360	1500	--	--	--
0,85	585	715	1120	1365	1500	--	--	--	1,02	540	645	1010	1255	1500	--	--	--
0,90	550	675	1055	1285	1500	--	--	--	1,08	505	610	955	1180	1435	1500	--	--
0,92	560	685	1070	1300	1500	--	--	--	1,11	515	620	965	1195	1455	1500	--	--
0,98	510	620	970	1180	1460	1500	--	--	1,18	465	560	875	1085	1320	1500	--	--
1,06	485	595	925	1130	1395	1500	--	--	1,28	445	535	835	1035	1260	1500	--	--
1,15	450	545	855	1040	1285	1500	--	--	1,38	410	495	770	955	1165	1470	1500	--
1,22	420	515	805	980	1215	1500	--	--	1,47	390	465	725	900	1095	1385	1500	--
1,33	390	475	740	900	1115	1385	1475	--	1,60	355	430	670	830	1010	1275	1475	--
1,74	310	380	590	720	890	1100	1355	1500	2,09	285	340	535	660	800	1015	1225	1500
2,01	270	325	510	620	770	955	1175	1430	2,41	245	295	460	570	695	880	1065	1310
2,17	245	300	470	575	710	880	1085	1320	2,61	230	275	425	530	640	810	980	1210
2,31	235	285	445	540	670	830	1020	1245	2,77	215	255	400	495	605	765	925	1140
2,51	215	260	410	495	615	760	940	1145	3,01	195	235	370	455	555	705	850	1045

50Hz									60Hz								
Motor Output [kW]																	
	VVVF AC2 4,2	VVVF AC2 5	VVVF AC2 7,5	VVVF AC2 9	VVVF 11	VVVF 13,5	VVVF 16,5	VVVF 20		VVVF AC2 4,7	VVVF AC2 5,5	VVVF AC2 8,2	VVVF AC2 10	VVVF 12	VVVF 15	VVVF 18	VVVF 22
Max Output Torque	Geared Efficiency								Max Output Torque	Geared Efficiency							
[Nm]									[Nm]								
3600	0,72	0,74	0,77	0,78	0,79	0,80	0,80	0,81	3600	0,71	0,73	0,76	0,77	0,78	0,79	0,80	0,80
3500	0,75	0,77	0,80	0,81	0,82	0,83	0,83	0,84	3500	0,74	0,76	0,79	0,80	0,81	0,82	0,83	0,84
3500	0,77	0,79	0,82	0,83	0,84	0,85	0,86	0,86	3500	0,76	0,78	0,81	0,83	0,84	0,85	0,85	0,86
3400	0,80	0,82	0,85	0,86	0,87	0,88	0,89	0,89	3400	0,79	0,81	0,84	0,86	0,87	0,88	0,88	0,89
3120	0,83	0,85	0,88	0,90	0,91	0,91	0,92	0,93	3120	0,82	0,84	0,88	0,89	0,90	0,91	0,92	0,92

50Hz														
VVVF 1500 rpm 4 Poles AC2 1500/375 rpm 4/16 Poles														
Asynchronous Rated Power [kW]														
	VVVF 7,5	VVVF 9,2	VVVF 11	VVVF 13,5	VVVF 16,5	VVVF 20	VVVF 25	VVVF 30	AC2 7,5	AC2 9	AC2 11	AC2 13,5	AC2 16,5	
Motor Parameters														
Rated Voltage (star connection) ^{(1) (3)}	[V]	400	400	400	400	400	400	400	400	400	400	400	400	400
Frequency	[Hz]	50	50	50	50	50	50	50	50	50	50	50	50	50
Synchronous Speed	[rpm]	1500	1500	1500	1500	1500	1500	1500	1500	1500/375	1500/375	1500/375	1500/375	1500/375
Asynchronous Speed	[rpm]	1458	1460	1457	1476	1477	1480	1481	1478	1386/297	1402/306	1370/300	1375/302	1368/298
Rated Current ⁽²⁾	[A]	17,3	21,2	24,1	27,4	34,1	37	45,8	61,7	18,3/14,9	20/16,7	29/17	33/19	39/22
Rated Torque	[Nm]	50	63	72	87	107	129	161	194	53	61	76	94	115
Cos ϕ Power Factor	[]	0,72	0,7	0,76	0,84	0,84	0,84	0,84	0,79	0,78	0,80	0,75	0,78	0,78
Starting Current	[A]	110	133	157	123	162	225	305	441	65	65	125	145	158
Starting Torque	[Nm]	117	145	163	160	190	253	357	380	134	147	183	208	236
Duty Cycle	[%]	60	60	60	60	60	60	60	60	30+10	30+10	30+10	30+10	30+10
Starts per Hour	[s/h]	240	240	240	240	240	240	240	240	180	180	180	180	180
Insulation Class	[]	F	F	F	F	F	F	F	F	F	F	F	F	F
Degree of Protection IP	[]	IP21	IP21	IP21	IP21	IP21	IP21	IP21	IP21	IP21	IP21	IP21	IP21	IP21

(1) The motors are standard supplied with star connection (Y), the customer can arrange a delta connection (Δ).

(2) The indicated current values are related to 400V voltage. For current values with delta connection, multiply the values by 1,732.

(3) The standard supply voltage is suitable for 380-400V/220-230V power supplies.

The geared machine includes a fan, 1~220...240V, 50/60Hz.

Available on request 115V supply voltage.

60Hz														
VVVF 1800 rpm 4 Poles AC2 1800/450 rpm 4/16 Poles														
Asynchronous Rated Power [kW]														
	VVVF 8,2	VVVF 10	VVVF 12	VVVF 15	VVVF 18	VVVF 22	VVVF 27	VVVF 33	AC2 8,2	AC2 10	AC2 12	AC2 15	AC2 18	
Motor Parameters														
Rated Voltage (star connection) ^{(1) (3)}	[V]	400	400	400	400	400	400	400	400	400	400	400	400	400
Frequency	[Hz]	60	60	60	60	60	60	60	60	60	60	60	60	60
Synchronous Speed	[rpm]	1800	1800	1800	1800	1800	1800	1800	1800	1800/450	1800/450	1800/450	1800/450	1800/450
Asynchronous Speed	[rpm]	1700	1710	1748	1774	1778	1779	1782	1781	1670/362	1664/373	1645/360	1650/358	1648/361
Rated Current ⁽²⁾	[A]	19,2	21,5	25,5	27	35	44	55	65	19,2/15	22/18,4	31/18	40/24	49/26
Rated Torque	[Nm]	46	56	65	81	97	118	145	177	47	57	68	87	104
Cos ϕ Power Factor	[]	0,75	0,76	0,76	0,84	0,84	0,85	0,84	0,86	0,76	0,80	0,75	0,76	0,76
Starting Current	[A]	110	131	150	128	160	229	301	432	70	105	120	103	128
Starting Torque	[Nm]	105	125	163	160	176	230	335	400	110	147	159	199	239
Duty Cycle	[%]	60	60	60	60	60	60	60	60	30+10	30+10	30+10	30+10	30+10
Starts per Hour	[s/h]	240	240	240	240	240	240	240	240	180	180	180	180	180
Insulation Class	[]	F	F	F	F	F	F	F	F	F	F	F	F	F
Degree of Protection IP	[]	IP21	IP21	IP21	IP21	IP21	IP21	IP21	IP21	IP21	IP21	IP21	IP21	IP21

(1) The motors are standard supplied with star connection (Y), the customer can arrange a delta connection (Δ).

(2) The indicated current values are related to 400V voltage. For current values with delta connection, multiply the values by 1,732.

(3) The standard supply voltage is suitable for 380-400V/220-230V power supplies.

The geared machine includes a fan, 1~220...240V, 50/60Hz.

Available on request 115V supply voltage.

50Hz

VVVF 1000 rpm 6 Poles
AC2 1000/375 rpm 6/16 Poles

Asynchronous Rated Power [kW]

VVVF 4,2	VVVF 5	VVVF 7,5	VVVF 9	VVVF 11	VVVF 13,5	VVVF 16,5	VVVF 20	AC2 4,2	AC2 5	AC2 7,5	AC2 9
Motor Parameters											
400	400	400	400	400	400	400	400	400	400	400	400
50	50	50	50	50	50	50	50	50	50	50	50
1000	1000	1000	1000	1000	1000	1000	1000	1000/375	1000/375	1000/375	1000/375
960	957	963	985	986	983	985	986	929/287	920/292	910/300	912/298
12,3	15,2	20	21	26,1	33	39	47	12,3/10	18/14	24/20	29/24
42	55	74	87	106	131	160	194	45,5	52	76	94
0,63	0,65	0,66	0,71	0,71	0,70	0,70	0,69	0,66	0,65	0,66	0,67
53	65	69	72	96	108	131	175	43	52	56	58
87	105	125	134	162	195	225	253	90	105	125	134
60	60	60	60	60	60	60	60	30+10	30+10	30+10	30+10
240	240	240	240	240	240	240	240	180	180	180	180
F	F	F	F	F	F	F	F	F	F	F	F
IP21	IP21	IP21	IP21	IP21	IP21	IP21	IP21	IP21	IP21	IP21	IP21

60Hz

VVVF 1200 rpm 6 Poles
AC2 1200/450 rpm 6/16 Poles

Asynchronous Rated Power [kW]

VVVF 4,7	VVVF 5,5	VVVF 8,2	VVVF 10	VVVF 12	VVVF 15	VVVF 18	VVVF 22	AC2 4,7	AC2 5,5	AC2 8,2	AC2 10
Motor Parameters											
400	400	400	400	400	400	400	400	400	400	400	400
60	60	60	60	60	60	60	60	60	60	60	60
1200	1200	1200	1200	1200	1200	1200	1200	1200/450	1200/450	1200/450	1200/450
1160	1148	1152	1175	1173	1176	1174	1174	1089/361	1090/360	1095/363	1092/365
14,1	15	21	22	25,8	33	38	46	16/13	22/18	27/22	35/26
39	46	68	81	98	122	146	179	41	46	68	87
0,61	0,7	0,67	0,72	0,71	0,72	0,72	0,73	0,62	0,61	0,66	0,65
59	72	76	79	106	119	144	193	47	57	62	64
79	95	112,5	121	146	175	202,5	228	81	95	113	121
60	60	60	60	60	60	60	60	30+10	30+10	30+10	30+10
240	240	240	240	240	240	240	240	180	180	180	180
F	F	F	F	F	F	F	F	F	F	F	F
IP21	IP21	IP21	IP21	IP21	IP21	IP21	IP21	IP21	IP21	IP21	IP21

Wrapping System	Traction sheave		Max n° Grooves x D	Grooves Pitch
	D [mm]	E [mm]	n° x mm	l [mm]
ESW	520	176	7xD10	24
	520	176	6xD13	30
	520	176	10xD10	16
	520	176	9xD11	18
	520	176	9xD12	18
	520	176	8xD13	19
	600	160	9xD10	16
	600	160	8xD11	18
	600	160	8xD12	18
	600	160	8xD13	19
	600	160	6xD14	22
	600	160	6xD15	22
	650	160	9xD10	16
	650	160	8xD11	18
	650	160	8xD12	18
	CSW	650	160	8xD13
650		160	6xD14	22
650		160	6xD15	22
650		160	6xD16	22
690		160	9xD10	16
690		160	8xD11	18
690		160	8xD12	18
690		160	8xD13	19
690		160	6xD14	22
690		160	6xD15	22
690		160	6xD16	22
750		160	9xD10	16
750		160	8xD11	18
750		160	8xD12	18
750		160	8xD13	19
750		160	6xD14	22
750	160	6xD15	22	
750	160	6xD16	22	

VCI

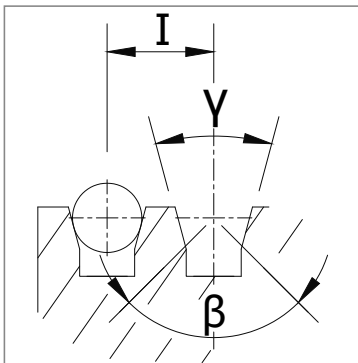

V grooves with undercut

UCI

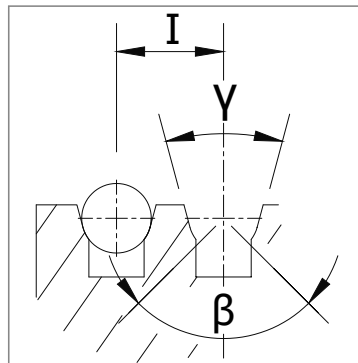

U grooves with undercut

γ = groove angle
 β = undercut angle
 I = grooves pitch

BEDPLATE | TOP MACHINE WITHOUT DIVERTING PULLEY FOR CSW WRAPPING

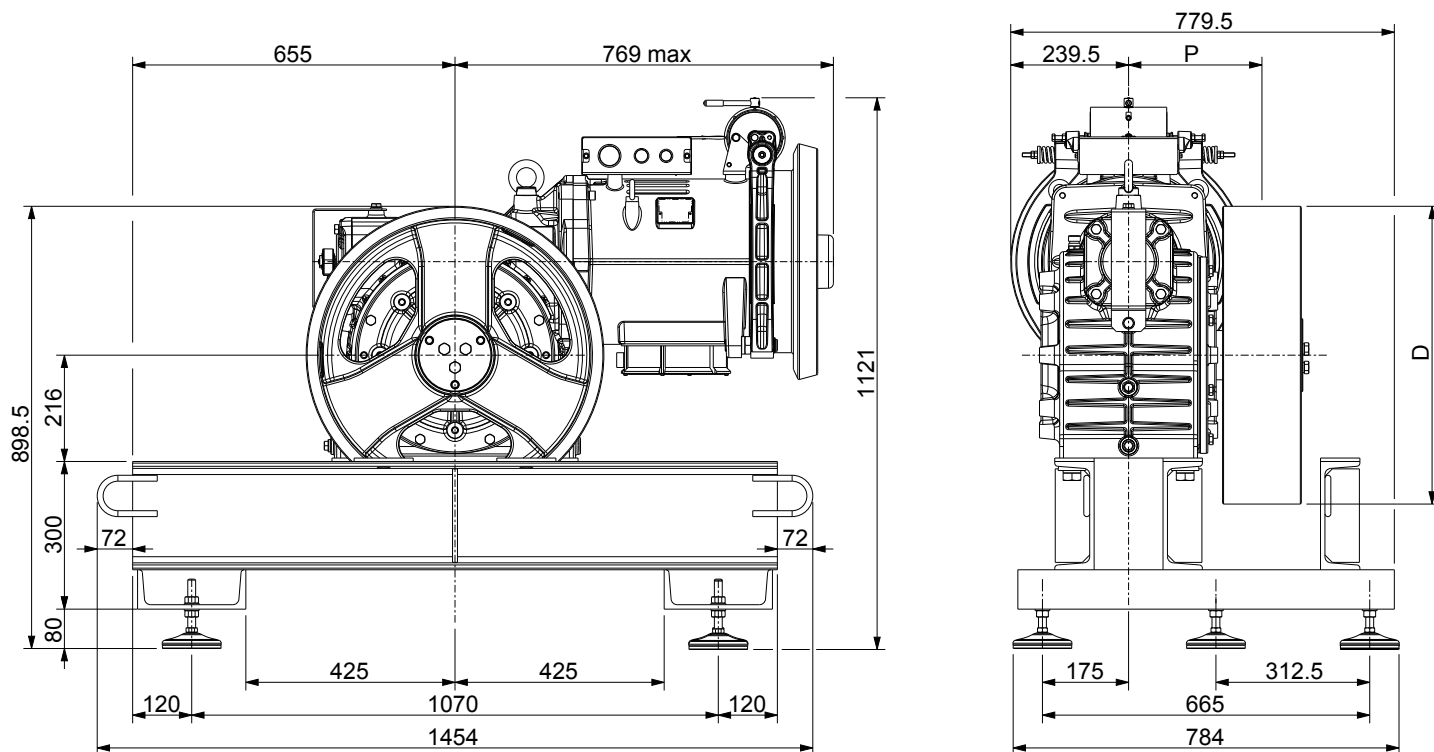

XTE3984 (included vibration dampers)
 Max weight of machine bedplate: 180 kg (bedplate + vibration dampers)

VIBRATIONS DAMPER SET UP

Damper code	Dimension
	[mm]
TAI0111	D.120x32

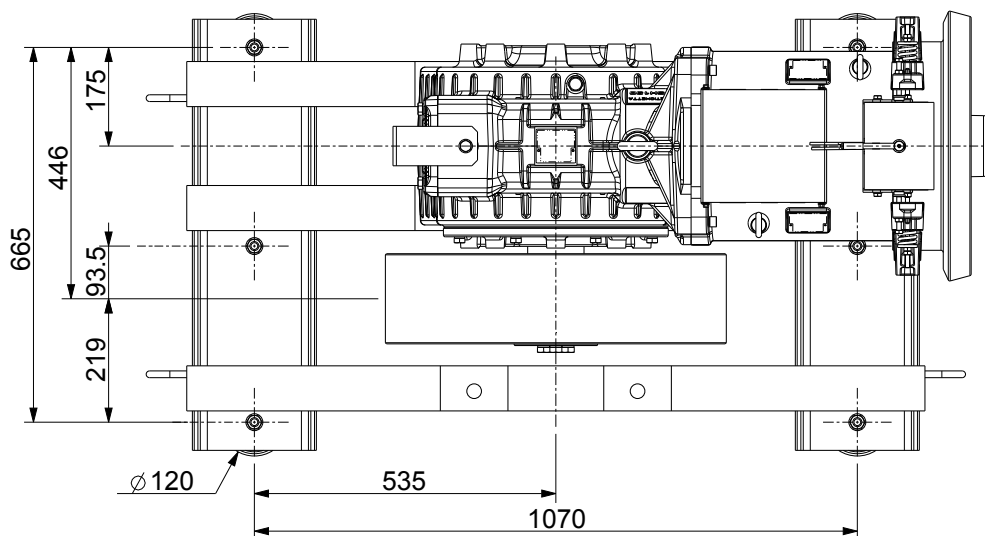

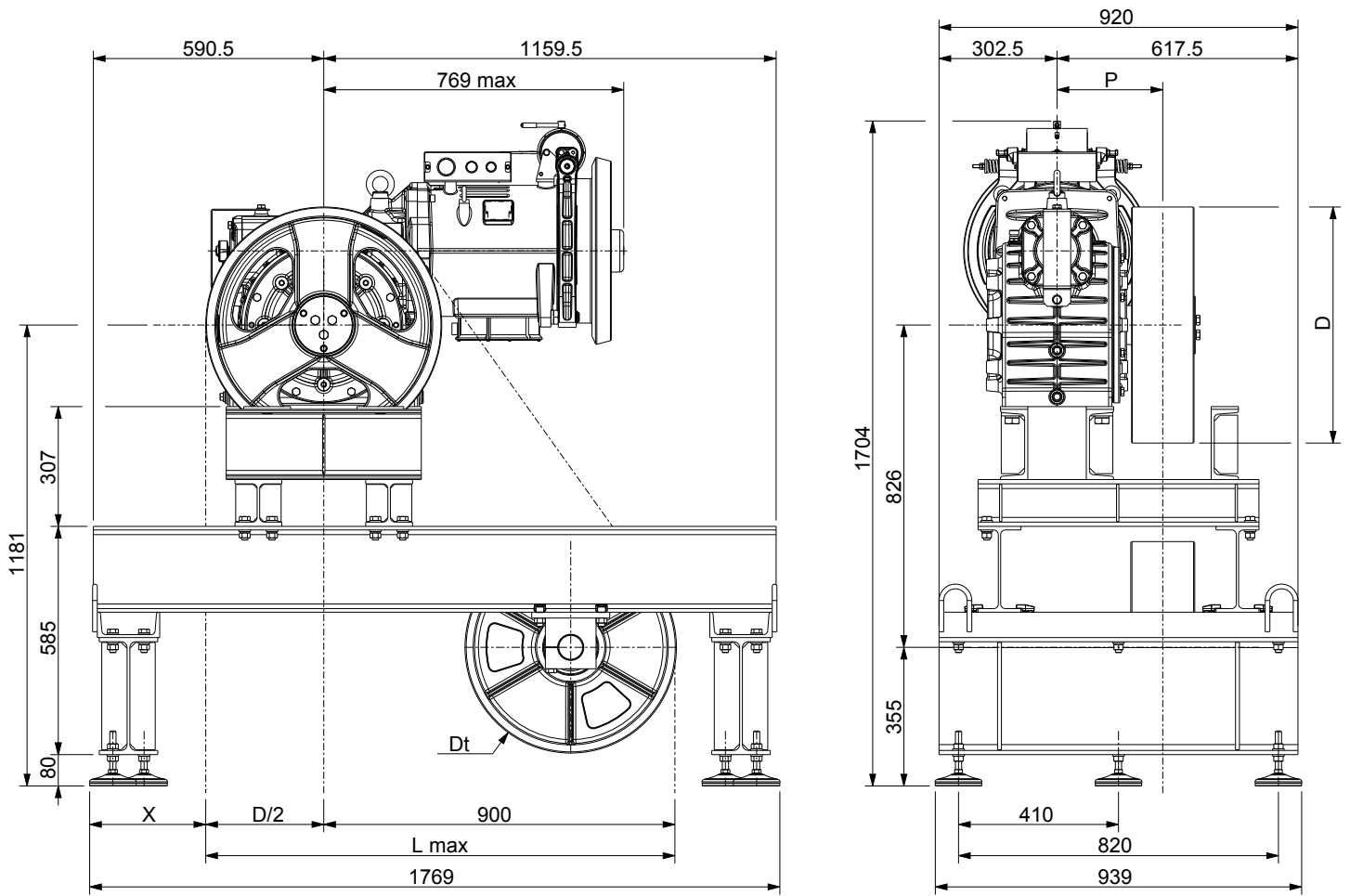

XTE3988 (included vibration dampers)
 Max weight of machine bedplate: 565 kg (bedplate + diverting pulley + vibration dampers)

VIBRATIONS DAMPER SET UP

Traction Sheave	X	L Max
D [mm]	[mm]	[mm]
520	340	1160
600	300	1200
650	275	1225
690	255	1245
750	225	1275

Damper code	Dimension
	[mm]
TAI0111	D.120x32

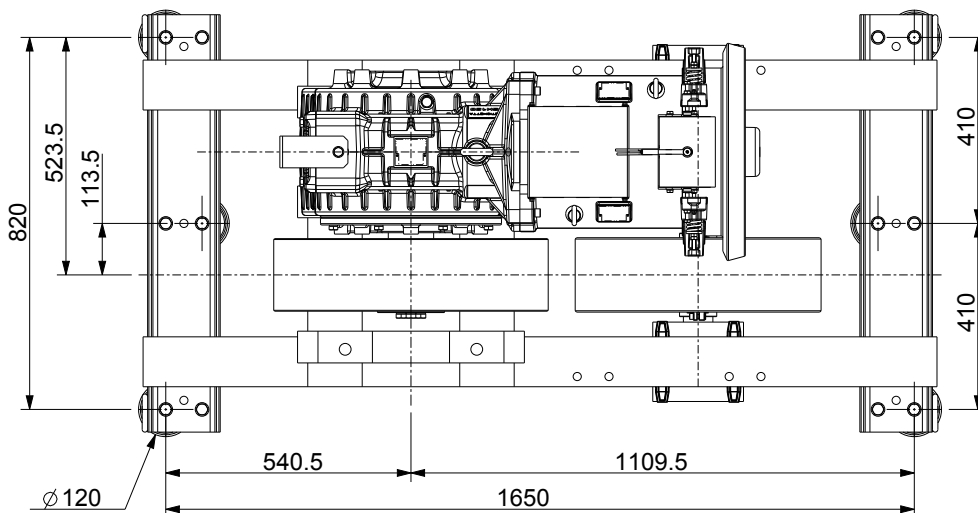

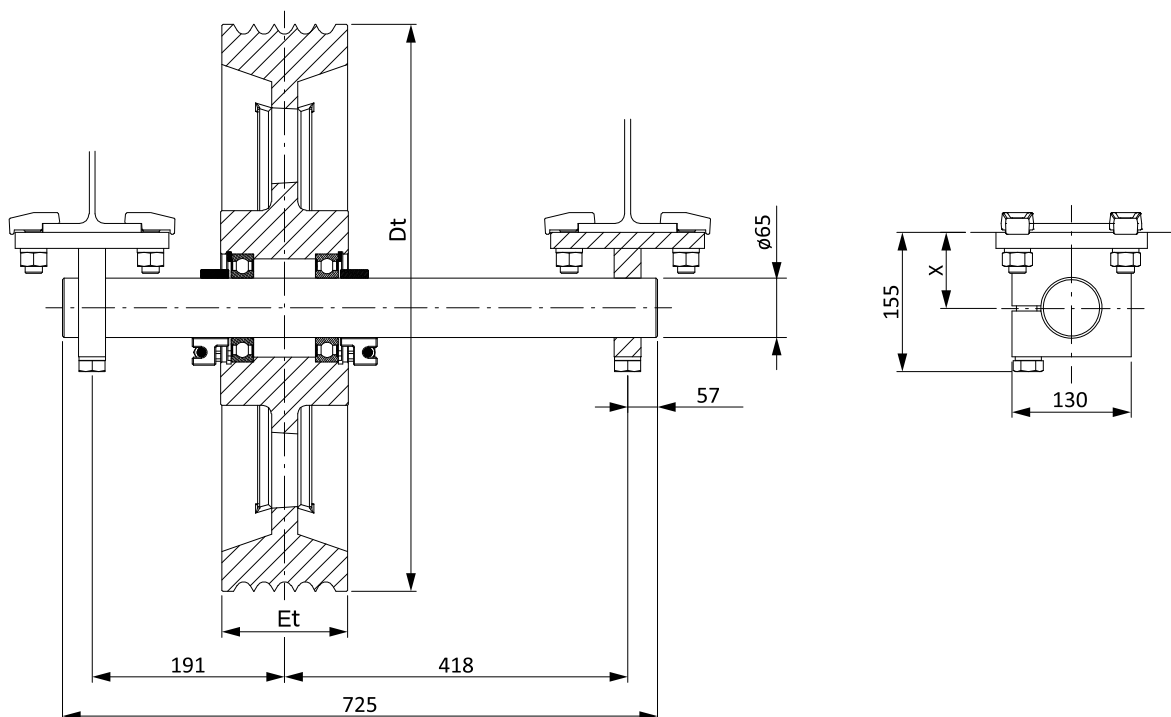
DIVERTING PULLEYS AND GROOVES NUMBER x ROPES DIAMETER

Diverting Pulley		Max n°Grooves x D	Grooves Pitch	Distance	Length	Force
Dt [mm]	Et [mm]	n° x mm	l [mm]	X [mm]	L [mm]	F Max [kN]
534	124	7xD10	16	72+90	725	23
		6xD12	18	72+90	725	23
		6xD13	19	72+90	725	23
	164	10xD10	16	72+90	725	24,2
		8xD12	18	72+90	725	24,2
		8xD13	19	72+90	725	24,2
656	186	11xD10	16	122	725	24,9
		10xD12	18	122	725	24,9
		9xD13	19	122	725	24,9
		8xD16	22	122	725	24,9

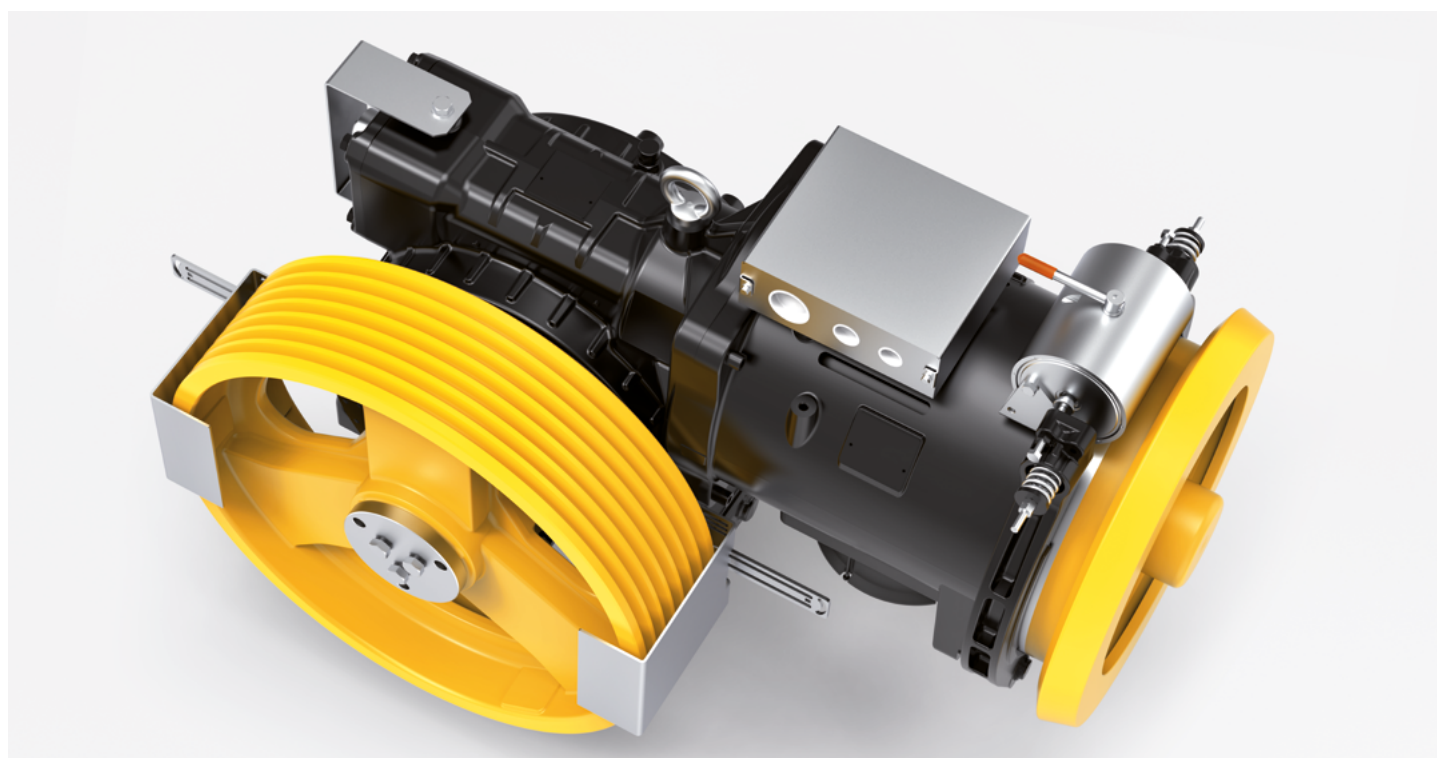

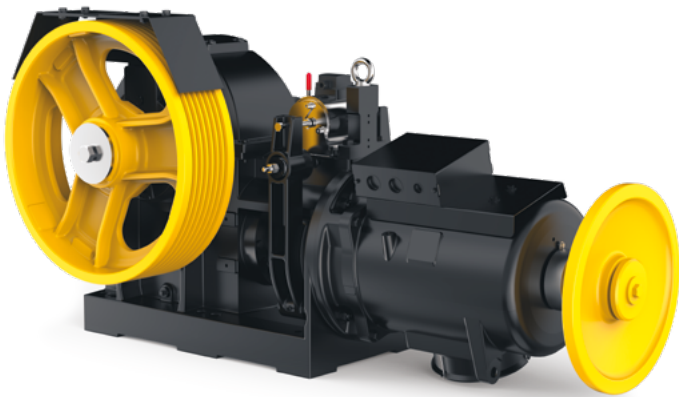

Max. Static Load MR21	55 kN - 5600 kg
Max. Static Load MR21TS	72,6 kN - 7400 kg
Power Range 50 Hz 4 poles ACVVVF	9 ÷ 30 kW
Power Range 50 Hz 4/16 poles	9 ÷ 16,5 kW
Power Range 50 Hz 6 poles ACVVVF	7,5 ÷ 20 kW
Power Range 50 Hz 6/16 poles	7,5 ÷ 13,5 kW
Power Range 60 Hz 4 poles ACVVVF	10 ÷ 33 kW
Power Range 60 Hz 4/16 poles	10 ÷ 18 kW
Power Range 60 Hz 6 poles ACVVVF	8,2 ÷ 22 kW
Power Range 60 Hz 6/16 poles	8,2 ÷ 15 kW
Ratio	1/62; 1/51; 1/40; 2/63; 2/51; 3/47
Gear Weight	770 ÷ 1000 kg
Oil capacity	7,8 l
Gear Box Rh o Lh (from motor side)	Image ref. to Lh geared

The geared machine efficiency values are present above each "rated load" table
 The motor efficiency values are present in the table "electric motor data"

DIMENSIONS MR21

Wrapping System	Traction sheave		Dimension	Load*)
	D [mm]	E [mm]		
ESW	520	176	303	50
	520	176		
CSW	600	160	290	55 - 5600
	650	160		
	690	160		
	750	160		

*) Max. static load on the slow shaft:
 CSW: Conventional single wrap
 ESW: Extended single wrap (patented)

Brake Electromagnet		
[V]	[A]	[W]
48	4,85	233
60	3,96	238
80	2,7	216
110	1,83	200
200	1,05	210

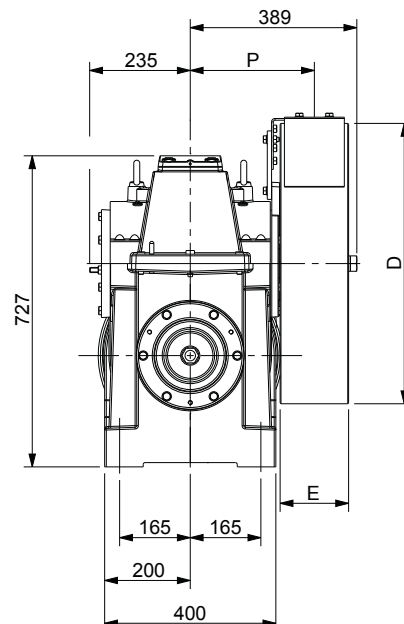
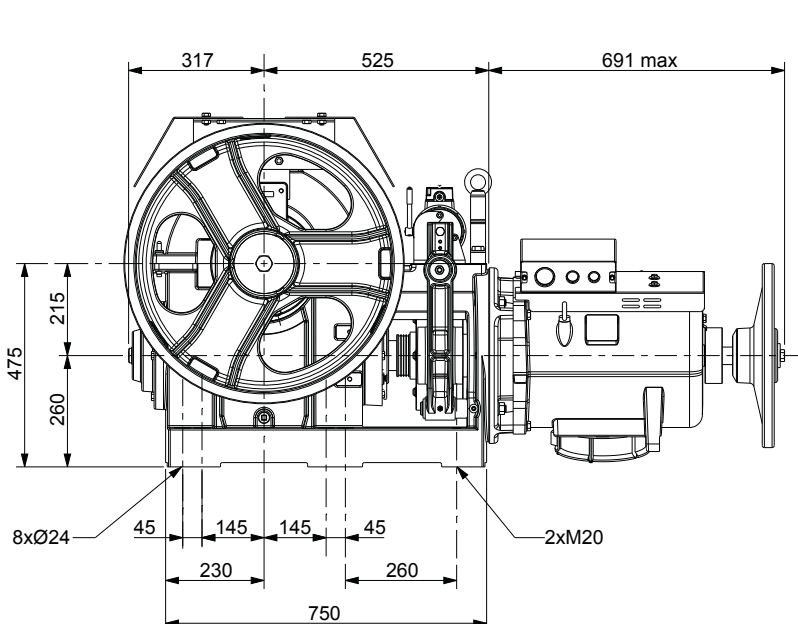

DIMENSIONS MR21TS

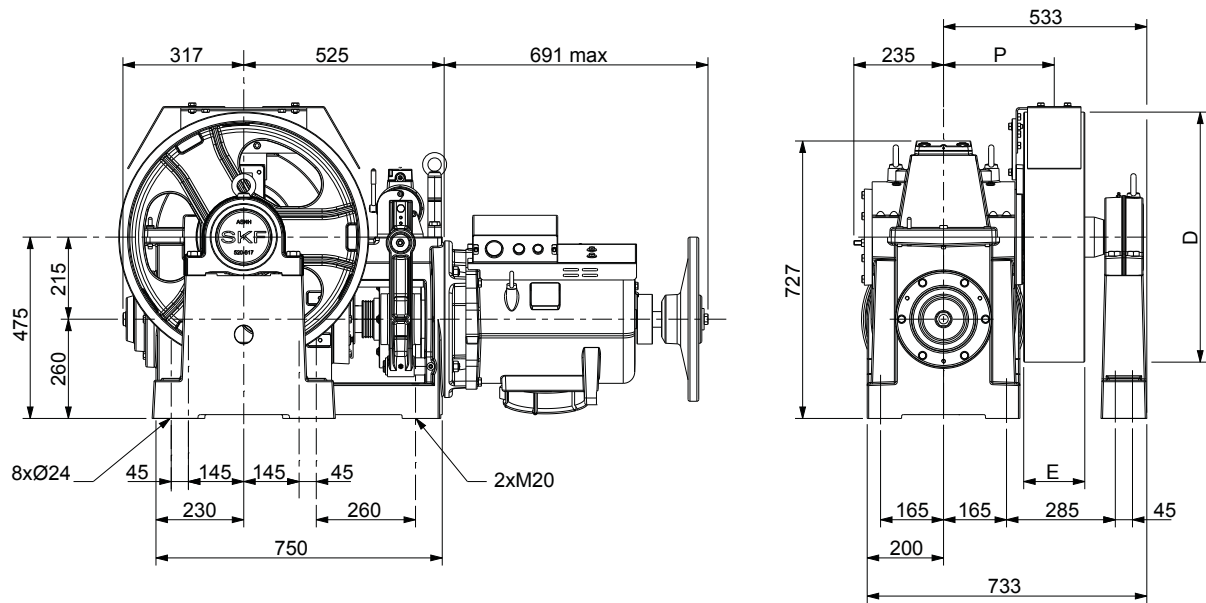

Wrapping System	Traction sheave		Dimension	Load*)
	D [mm]	E [mm]		
ESW	520	176	303	62,8 - 6400
	520	176		
CSW	600	160	290	72,6 - 7400
	650	160		
	690	160		
	750	160		

*) Max. static load on the slow shaft:
 CSW: Conventional single wrap
 ESW: Extended single wrap (patented)



				50Hz								60Hz								
				VVVF 1500 rpm 4 Poles AC2 1500/375 rpm 4/16 Poles								VVVF 1800 rpm 4 Poles AC2 1800/450 rpm 4/16 Poles								
				Motor Output [kW]																
Pa		q _a		VVVF AC2 9	VVVF AC2 11	VVVF AC2 13,5	VVVF AC2 16,5	VVVF 20	VVVF 25	VVVF 30		VVVF AC2 10	VVVF AC2 12	VVVF AC2 15	VVVF AC2 18	VVVF 22	VVVF 27	VVVF 33		
Wrapping system	R.R.	Trac. Sheave Ø	Speed syn.	Max Rated Load								Speed syn.	Max Rated Load							
CSW ESW	[i]	[mm]	[m/s]	[kg]	[kg]	[kg]	[kg]	[kg]	[kg]	[kg]	[m/s]	[kg]	[kg]	[kg]	[kg]	[kg]	[kg]	[kg]		
X X	1/62	520	0,66	1440	1835	2045	--	--	--	--	0,79	1335	1635	--	--	--	--	--		
X --	1/62	600	0,76	1245	1590	1770	--	--	--	--	0,91	1155	1415	--	--	--	--	--		
X X	1/51	520	0,80	1205	1540	1960	2100	--	--	--	0,96	1115	1395	1765	--	--	--	--		
X --	1/62	650	0,82	1150	1470	1635	--	--	--	--	0,99	1070	1305	--	--	--	--	--		
X --	1/62	690	0,87	1085	1385	1540	--	--	--	--	1,05	1005	1230	--	--	--	--	--		
X --	1/51	600	0,92	1040	1335	1700	1910	--	--	--	1,11	970	1210	1530	--	--	--	--		
X --	1/62	750	0,95	995	1275	1415	--	--	--	--	1,14	925	1135	--	--	--	--	--		
X --	1/51	650	1,00	960	1230	1565	1765	--	--	--	1,20	895	1115	1415	--	--	--	--		
X X	1/40	520	1,02	945	1215	1550	1960	2100	--	--	1,23	885	1110	1450	1785	1890	--	--		
X --	1/51	690	1,06	905	1160	1475	1660	--	--	--	1,28	840	1050	1330	--	--	--	--		
X --	1/51	750	1,15	835	1065	1360	1530	--	--	--	1,39	775	970	1225	--	--	--	--		
X --	1/40	600	1,18	815	1050	1345	1695	2100	--	--	1,41	765	960	1255	1550	1640	--	--		
X --	1/40	650	1,28	755	970	1240	1565	1945	2000	--	1,53	705	890	1160	1430	1515	--	--		
X X	2/63	520	1,30	800	1020	1295	1625	2010	2100	--	1,56	740	925	1200	1475	1690	--	--		
X --	1/40	690	1,35	710	915	1170	1475	1830	1885	--	1,63	665	835	1090	1345	1425	--	--		
X --	1/40	750	1,47	655	840	1075	1355	1685	1735	--	1,77	615	770	1005	1240	1310	--	--		
X --	2/63	600	1,50	690	885	1120	1410	1745	1835	--	1,80	640	800	1040	1280	1465	--	--		
X X	2/51	520	1,60	645	825	1050	1320	1635	2085	2100	1,92	600	750	975	1200	1500	1750	--		
X --	2/63	650	1,62	640	815	1035	1300	1610	1695	--	1,94	595	740	960	1180	1350	--	--		
X --	2/63	690	1,72	600	765	975	1225	1515	1595	--	2,06	560	695	905	1110	1275	--	--		
X --	2/51	600	1,85	560	715	910	1145	1415	1805	1890	2,22	520	650	845	1040	1300	1515	--		
X --	2/63	750	1,87	555	705	895	1125	1395	1470	--	2,24	515	640	830	1025	1170	--	--		
X --	2/51	650	2,00	515	660	840	1055	1305	1665	1745	2,40	480	600	780	960	1200	1400	--		
X --	2/51	690	2,13	485	620	790	995	1230	1570	1645	2,55	450	565	730	900	1130	1315	--		
X --	2/51	750	2,31	445	570	725	915	1130	1445	1510	2,77	415	520	675	830	1040	1210	--		
X X	3/47	520	2,61	400	515	655	825	1025	1305	1590	3,13	370	465	605	745	935	1170	1455		
X --	3/47	600	3,01	345	445	570	715	885	1130	1375	3,61	320	400	525	645	810	1015	1260		
X --	3/47	650	3,26	320	410	525	660	820	1045	1270	3,91	295	370	485	595	750	935	1165		
X --	3/47	690	3,46	300	385	495	620	770	985	1195	4,15	280	350	455	560	705	880	1095		
X --	3/47	750	3,76	275	355	455	570	710	905	1100	4,51	255	320	420	515	650	810	1010		

				50Hz								60Hz							
				Motor Output [kW]															
				VVVF AC2 9	VVVF AC2 11	VVVF AC2 13,5	VVVF AC2 16,5	VVVF 20	VVVF 25	VVVF 30		VVVF AC2 10	VVVF AC2 12	VVVF AC2 15	VVVF AC2 18	VVVF 22	VVVF 27	VVVF 33	
R.R.	Max Output Torque	Geared Efficiency								Max Output Torque	Geared Efficiency								
[i]	[Nm]									[Nm]									
1/62	3260	0,68	0,71	0,73	0,75	0,77	0,78	0,79	2610	0,68	0,71	0,73	0,75	0,77	0,78	0,79			
1/51	3520	0,69	0,72	0,75	0,77	0,79	0,80	0,81	2820	0,69	0,72	0,75	0,77	0,79	0,80	0,81			
1/40	3990	0,69	0,73	0,76	0,78	0,80	0,82	0,83	3020	0,70	0,73	0,76	0,78	0,80	0,82	0,83			
2/63	3380	0,74	0,78	0,80	0,82	0,84	0,86	0,87	2700	0,74	0,77	0,80	0,82	0,84	0,86	0,87			
2/51	3480	0,74	0,77	0,80	0,83	0,84	0,86	0,87	2790	0,74	0,77	0,80	0,83	0,84	0,86	0,87			
3/47	3560	0,75	0,79	0,82	0,84	0,86	0,88	0,89	3000	0,75	0,78	0,82	0,84	0,86	0,88	0,89			

Rated load values listed in the table include the weight of the ropes.
 To know the theoretical load, subtract the weight of the ropes.
 Position Of The Geared = Top Counterweight = 50% Plant efficiency = 0,80

50Hz							60Hz						
VVVF 1000 rpm 6 Poles AC2 1000/375 rpm 6/16 Poles							VVVF 1200 rpm 6 Poles AC2 1200/450 rpm 6/16 Poles						
Motor Output [kW]													
	VVVF AC2 7,5	VVVF AC2 9	VVVF AC2 11	VVVF AC2 13,5	VVVF 16,5	VVVF 20		VVVF AC2 8,2	VVVF AC2 10	VVVF AC2 12	VVVF AC2 15	VVVF AC2 18	VVVF AC2 22
Speed syn.	Max Rated Load						Speed syn.	Max Rated Load					
[m/s]	[kg]	[kg]	[kg]	[kg]	[kg]	[kg]	[m/s]	[kg]	[kg]	[kg]	[kg]	[kg]	[kg]
0,44	1900	2045	--	--	--	--	0,53	1695	2045	--	--	--	--
0,51	1645	1770	--	--	--	--	0,61	1470	1770	--	--	--	--
0,53	1595	1970	2100	--	--	--	0,64	1420	1800	2100	--	--	--
0,55	1520	1635	--	--	--	--	0,66	1355	1635	--	--	--	--
0,58	1430	1540	--	--	--	--	0,70	1280	1540	--	--	--	--
0,62	1380	1710	1910	--	--	--	0,74	1230	1560	1910	--	--	--
0,63	1315	1415	--	--	--	--	0,76	1175	1415	--	--	--	--
0,67	1275	1575	1765	--	--	--	0,80	1135	1440	1765	--	--	--
0,68	1255	1560	1965	2100	--	--	0,82	1115	1420	1760	2100	--	--
0,71	1200	1485	1660	--	--	--	0,85	1070	1355	1660	--	--	--
0,77	1105	1365	1530	--	--	--	0,92	985	1245	1530	--	--	--
0,79	1090	1350	1705	2100	--	--	0,94	965	1230	1525	1965	2100	--
0,85	1005	1245	1570	1975	2035	--	1,02	890	1135	1405	1810	2035	--
0,86	1055	1305	1635	2045	2100	--	1,04	940	1190	1465	1880	2100	--
0,90	945	1175	1480	1860	1915	--	1,08	840	1070	1325	1705	1915	--
0,98	870	1080	1360	1715	1765	--	1,18	775	985	1220	1570	1765	--
1,00	915	1130	1415	1775	1835	--	1,20	815	1030	1270	1625	1835	--
1,07	855	1055	1325	1665	2070	2100	1,28	760	965	1190	1525	1865	2100
1,08	845	1040	1305	1635	1695	--	1,30	755	950	1170	1500	1695	--
1,15	795	980	1230	1540	1595	--	1,38	710	895	1105	1415	1595	--
1,23	740	915	1150	1440	1790	1890	1,48	660	835	1030	1320	1615	1890
1,25	730	905	1130	1420	1470	--	1,50	650	825	1015	1300	1470	--
1,33	680	845	1060	1330	1655	1745	1,60	610	770	950	1220	1490	1745
1,42	645	795	1000	1255	1560	1645	1,70	570	725	895	1150	1405	1645
1,54	590	730	920	1150	1435	1510	1,85	525	665	825	1055	1290	1510
1,74	530	660	830	1040	1295	1595	2,09	475	600	745	955	1165	1450
2,01	460	570	720	905	1125	1380	2,41	410	520	645	825	1010	1255
2,17	425	525	665	835	1035	1275	2,61	380	480	595	765	935	1160
2,31	400	495	625	785	975	1200	2,77	355	450	560	720	880	1090
2,51	370	455	575	720	900	1105	3,01	330	415	515	660	810	1005

50Hz							60Hz						
Motor Output [kW]													
	VVVF AC2 7,5	VVVF AC2 9	VVVF AC2 11	VVVF AC2 13,5	VVVF 16,5	VVVF 20		VVVF AC2 8,2	VVVF AC2 10	VVVF AC2 12	VVVF AC2 15	VVVF AC2 18	VVVF AC2 22
Max Output Torque	Geared Efficiency						Max Output Torque	Geared Efficiency					
[Nm]							[Nm]						
3260	0,72	0,74	0,76	0,77	0,79	0,80	3260	0,70	0,73	0,75	0,77	0,78	0,79
3520	0,73	0,75	0,77	0,79	0,80	0,82	3520	0,72	0,74	0,76	0,78	0,80	0,81
4060	0,73	0,76	0,78	0,80	0,82	0,83	4060	0,72	0,75	0,77	0,79	0,81	0,82
3380	0,78	0,81	0,83	0,84	0,86	0,87	3380	0,77	0,80	0,82	0,84	0,85	0,86
3480	0,78	0,81	0,83	0,85	0,86	0,87	3480	0,77	0,80	0,82	0,84	0,85	0,87
3560	0,80	0,82	0,85	0,87	0,88	0,89	3560	0,78	0,81	0,83	0,86	0,87	0,89

50Hz											
VVVF 1500 rpm 4 Poles AC2 1500/375 rpm 4/16 Poles											
Asynchronous Rated Power [kW]											
	VVVF 9	VVVF 11	VVVF 13,5	VVVF 16,5	VVVF 20	VVVF 25	VVVF 30	AC2 9	AC2 11	AC2 13,5	AC2 16,5
Motor Parameters											
Rated Voltage (star connection) ^{(1) (3)} [V]	400	400	400	400	400	400	400	400	400	400	400
Frequency [Hz]	50	50	50	50	50	50	50	50	50	50	50
Synchronous Speed [rpm]	1500	1500	1500	1500	1500	1500	1500	1500/375	1500/375	1500/375	1500/375
Asynchronous Speed [rpm]	1460	1457	1476	1477	1480	1481	1478	1402/306	1370/300	1375/302	1368/298
Rated Current ⁽²⁾ [A]	21,2	24,1	27,4	34,1	37	45,8	61,7	20/16,7	29/17	33/19	39/22
Rated Torque [Nm]	63	72	87	107	129	161	194	61	76	94	115
Cos φ Power Factor []	0,7	0,76	0,84	0,84	0,84	0,84	0,79	0,8	0,75	0,78	0,78
Starting Current [A]	133	157	123	162	225	305	441	65	125	145	158
Starting Torque [Nm]	145	163	160	190	253	357	380	147	183	208	236
Duty Cycle [%]	60	60	60	60	60	60	60	30+10	30+10	30+10	30+10
Starts per Hour [s/h]	240	240	240	240	240	240	240	180	180	180	180
Insulation Class []	F	F	F	F	F	F	F	F	F	F	F
Degree of Protection IP []	IP21	IP21	IP21	IP21	IP21	IP21	IP21	IP21	IP21	IP21	IP21

(1) The motors are standard supplied with star connection (Y), the customer can arrange a delta connection (Δ).

(2) The indicated current values are related to 400V voltage. For current values with delta connection, multiply the values by 1,732.

Motor are manufactured for 50Hz. Inverter must assure those frequencies and voltages independently from the net frequency.

(3) The standard supply voltage is suitable for 380-400V/220-230V power supplies.

The geared machine includes a fan, 1~220...240V, 50/60Hz.

60Hz											
VVVF 1800 rpm 4 Poles AC2 1800/450 rpm 4/16 Poles											
Asynchronous Rated Power [kW]											
	VVVF 10	VVVF 12	VVVF 15	VVVF 18	VVVF 22	VVVF 27	VVVF 33	AC2 10	AC2 12	AC2 15	AC2 18
Motor Parameters											
Rated Voltage (star connection) ^{(1) (3)} [V]	400	400	400	400	400	400	400	400	400	400	400
Frequency [Hz]	60	60	60	60	60	60	60	60	60	60	60
Synchronous Speed [rpm]	1800	1800	1800	1800	1800	1800	1800	1800/450	1800/450	1800/450	1800/450
Asynchronous Speed [rpm]	1710	1748	1774	1778	1779	1782	1781	1664/373	1645/360	1650/358	1648/361
Rated Current ⁽²⁾ [A]	21,5	25,5	27	35	44	55	65	22/18,4	31/18	40/24	49/26
Rated Torque [Nm]	56	65	81	97	118	145	177	57	68	87	104
Cos φ Power Factor []	0,76	0,76	0,84	0,84	0,85	0,84	0,86	0,8	0,75	0,76	0,76
Starting Current [A]	131	150	128	160	229	301	432	105	120	103	128
Starting Torque [Nm]	125	163	160	176	230	335	400	147	159	199	239
Duty Cycle [%]	60	60	60	60	60	60	60	30+10	30+10	30+10	30+10
Starts per Hour [s/h]	240	240	240	240	240	240	240	180	180	180	180
Insulation Class []	F	F	F	F	F	F	F	F	F	F	F
Degree of Protection IP []	IP21	IP21	IP21	IP21	IP21	IP21	IP21	IP21	IP21	IP21	IP21

(1) The motors are standard supplied with star connection (Y), the customer can arrange a delta connection (Δ).

(2) The indicated current values are related to 400V voltage. For current values with delta connection, multiply the values by 1,732.

Motor are manufactured for 60Hz. Inverter must assure those frequencies and voltages independently from the net frequency.

(3) The standard supply voltage is suitable for 380-400V/220-230V power supplies.

The geared machine is fan cooled with a fan mounted on the motor shaft or force ventilated with external fan 1 ~ 220 ... 240V 50/60Hz

50Hz

VVVF 1000 rpm 6 Poles
AC2 1000/375 rpm 6/16 Poles

Asynchronous Rated Power [kW]

VVVF 7,5	VVVF 9	VVVF 11	VVVF 13,5	VVVF 16,5	VVVF 20	AC2 7,5	AC2 9	AC2 11	AC2 13,5
Motor Parameters									
400	400	400	400	400	400	400	400	400	400
50	50	50	50	50	50	50	50	50	50
1000	1000	1000	1000	1000	1000	1000/375	1000/375	1000/375	1000/375
963	980	980	981	982	981	910/300	912/298	914/296	920/299
20	21	26	33	39	47	24/20	29/24	31/29	34/31
74	87	107	131	160	194	76	94	113	139
0,66	0,7	0,72	0,7	0,7	0,71	0,66	0,67	0,68	0,67
69	96	123	163	201	245	56	58	107	145
125	107	144	200	242	314	125	134	274	350
60	60	60	60	60	60	30+10	30+10	30+10	30+10
240	240	240	240	240	240	180	180	180	180
F	F	F	F	F	F	F	F	F	F
IP21	IP21	IP21	IP21	IP21	IP21	IP21	IP21	IP21	IP21

60Hz

VVVF 1200 rpm 6 Poles
AC2 1200/450 rpm 6/16 Poles

Asynchronous Rated Power [kW]

VVVF 8,2	VVVF 10	VVVF 12	VVVF 15	VVVF 18	VVVF 22	AC2 8,2	AC2 10	AC2 12	AC2 15
Motor Parameters									
400	400	400	400	400	400	400	400	400	400
60	60	60	60	60	60	60	60	60	60
1200	1200	1200	1200	1200	1200	1200/450	1200/450	1200/450	1200/450
1152	1175	1173	1176	1174	1174	1095/363	1092/365	1091/359	1093/361
21	22	25,8	33	38	46	27/22	35/26	36/31	43/37
68	81	98	122	146	179	68	87	105	131
0,67	0,72	0,71	0,72	0,72	0,73	0,66	0,65	0,67	0,66
76	79	106	119	144	193	62	64	134	165
112	121	146	175	202	228	113	121	247	310
60	60	60	60	60	60	30+10	30+10	30+10	30+10
240	240	240	240	240	240	180	180	180	180
F	F	F	F	F	F	F	F	F	F
IP21	IP21	IP21	IP21	IP21	IP21	IP21	IP21	IP21	IP21

(1) The motors are standard supplied with star connection (Y), the customer can arrange a delta connection (Δ).

(2) The indicated current values are related to 400V voltage. For current values with delta connection, multiply the values by 1,732.

(3) The standard supply voltage is suitable for 380-400V/220-230V power supplies.

The geared machine is fan cooled with a fan mounted on the motor shaft or force ventilated with external fan 1 ~ 220 ... 240V 50/60Hz

Wrapping System	Traction sheave		Max n° Grooves x D	Grooves Pitch
	D [mm]	E [mm]	n° x mm	l [mm]
ESW	520	176	7xD10	24
	520	176	6xD13	30
	520	176	10xD10	16
	520	176	9xD11	18
	520	176	9xD12	18
	520	176	8xD13	19
	600	160	9xD10	16
	600	160	8xD11	18
	600	160	8xD12	18
	600	160	8xD13	19
	600	160	6xD14	22
	600	160	6xD15	22
	650	160	9xD10	16
	650	160	8xD11	18
	CSW	650	160	8xD12
650		160	8xD13	19
650		160	6xD14	22
650		160	6xD15	22
650		160	6xD16	22
690		160	9xD10	16
690		160	8xD11	18
690		160	8xD12	18
690		160	8xD13	19
690		160	6xD14	22
690		160	6xD15	22
690		160	6xD16	22
750		160	9xD10	16
750		160	8xD11	18
750		160	8xD12	18
750	160	8xD13	19	
750	160	6xD14	22	
750	160	6xD15	22	
750	160	6xD16	22	

VCI

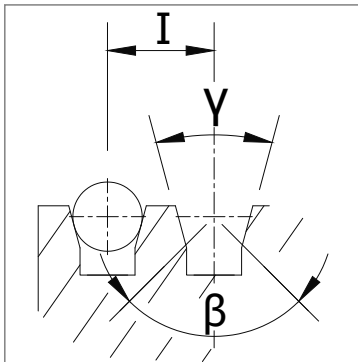

V grooves with undercut

UCI

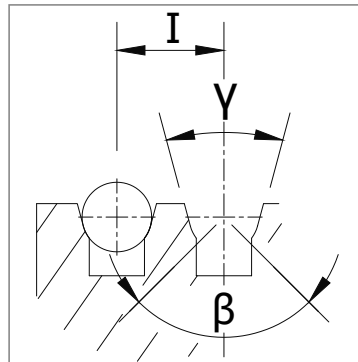

U grooves with undercut

γ = groove angle
 β = undercut angle
 I = grooves pitch

BEDPLATE | TOP MACHINE WITHOUT DIVERTING PULLEY FOR CSW WINDING (SHORT)

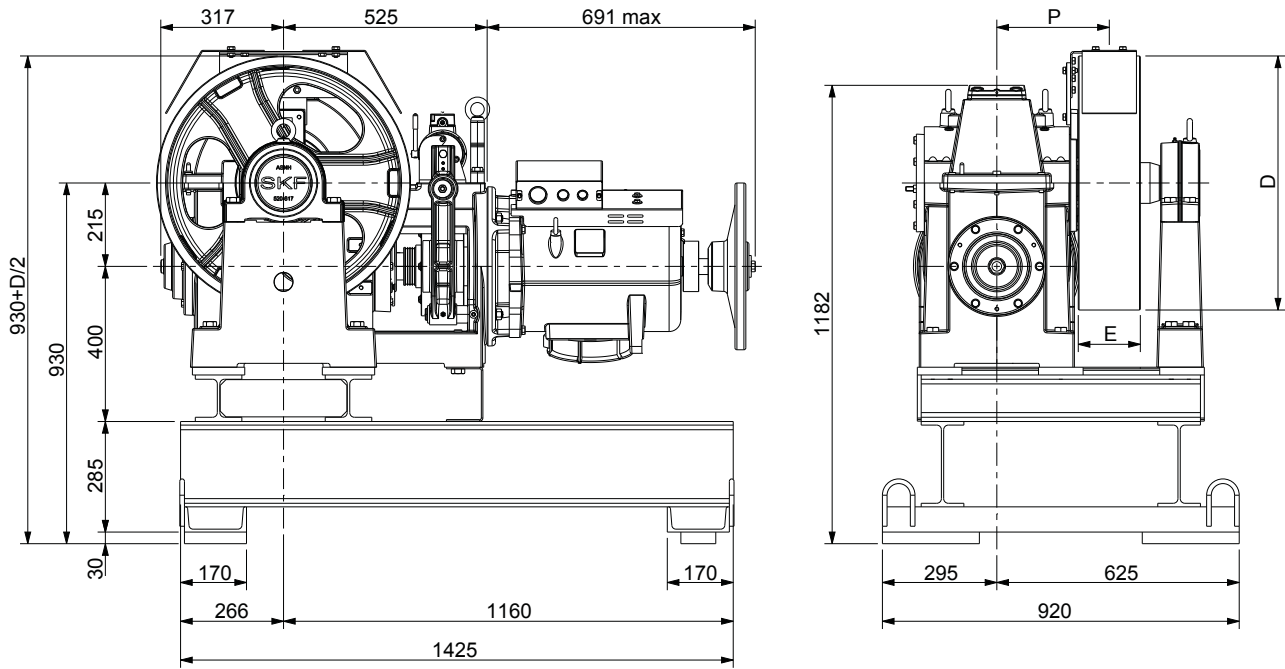

MR21 XTE0025 Weight of machine bedplate: 175 kg.
 MR21TS XTE2953 Weight of machine bedplate: 224 kg
 Note: Machine room floor thickness min. 250 mm. The bed plate includes vibration dampers

BEDPLATE | TOP MACHINE WITH DIVERTING PULLEY FOR CSW WINDING (SHORT)

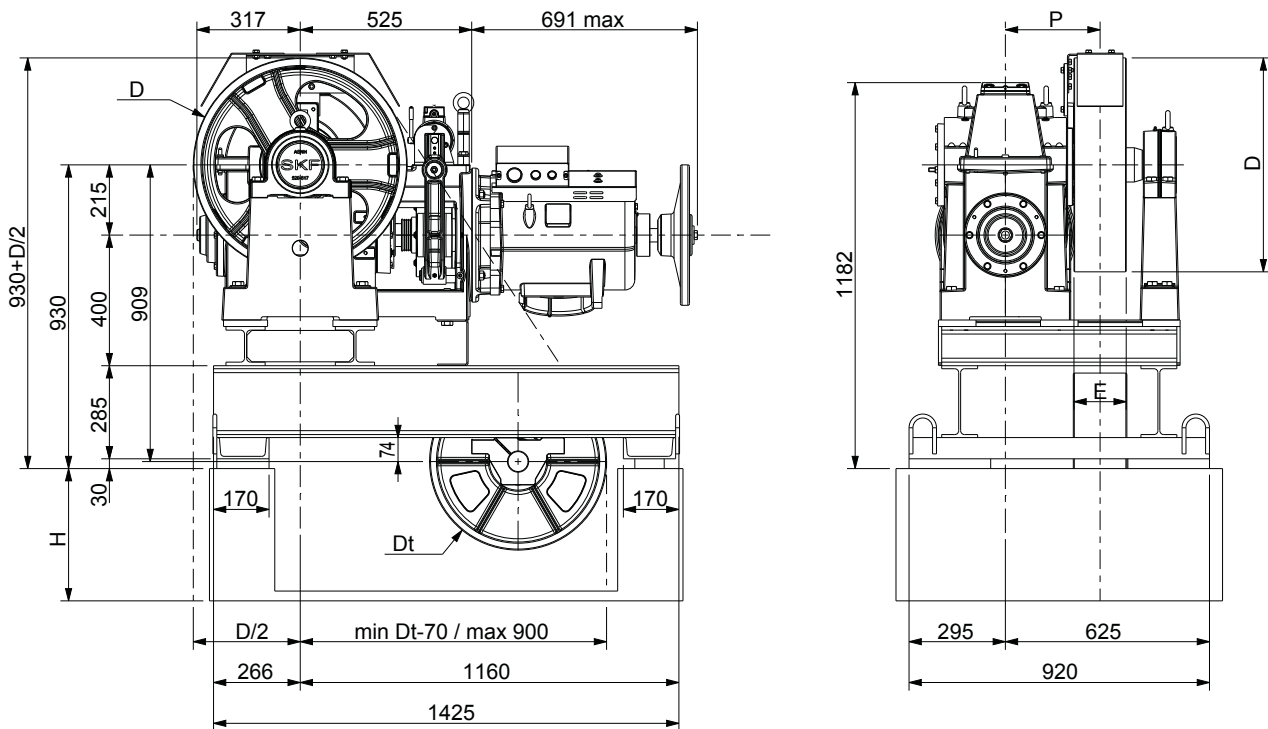

MR21 XTE0029 Weight of machine bedplate: 175 kg.
 MR21TS XTE2955 Weight of machine bedplate: 253 kg
 Note: Machine room floor thickness min. 250 mm. The bed plate includes vibration dampers (without diverting pulley)
 Dt = 534 mm
 Dimension Hmin = (Dt/2) + 75

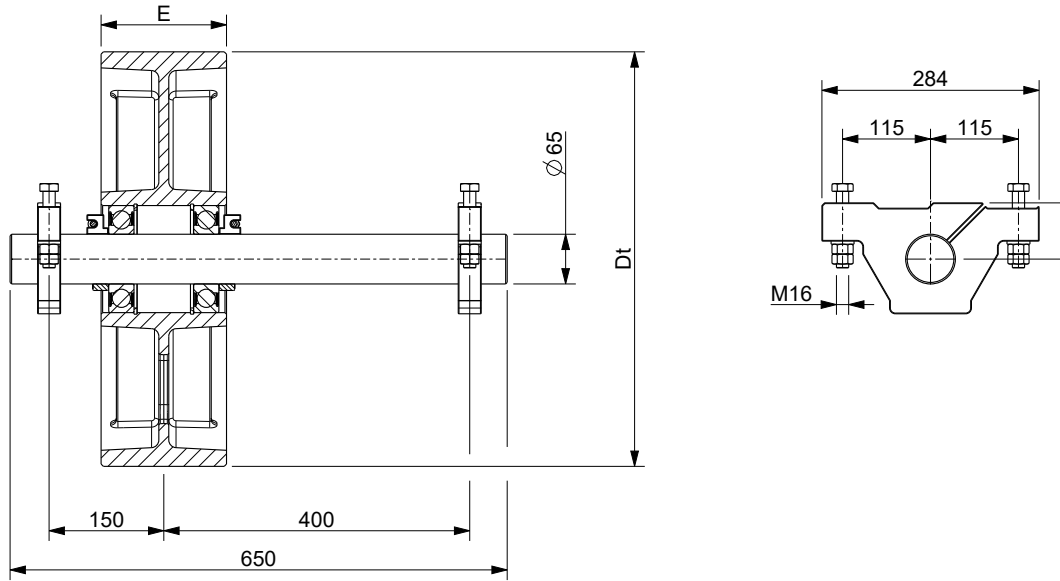

Diverting Pulley		Max n° Grooves x D	Grooves Pitch	Distance	Length	Force
Dt [mm]	Et [mm]	n° x mm	l [mm]	X [mm]	L [mm]	F Max [kN]
534	124	7xD10	16	72+90	725	23
		6xD12	18	72+90	725	23
		6xD13	19	72+90	725	23
	164	10xD10	16	72+90	725	24,2
		8xD12	18	72+90	725	24,2
		8xD13	19	72+90	725	24,2
656	186	11xD10	16	122	725	24,9
		10xD12	18	122	725	24,9
		9xD13	19	122	725	24,9
		8xD16	22	122	725	24,9

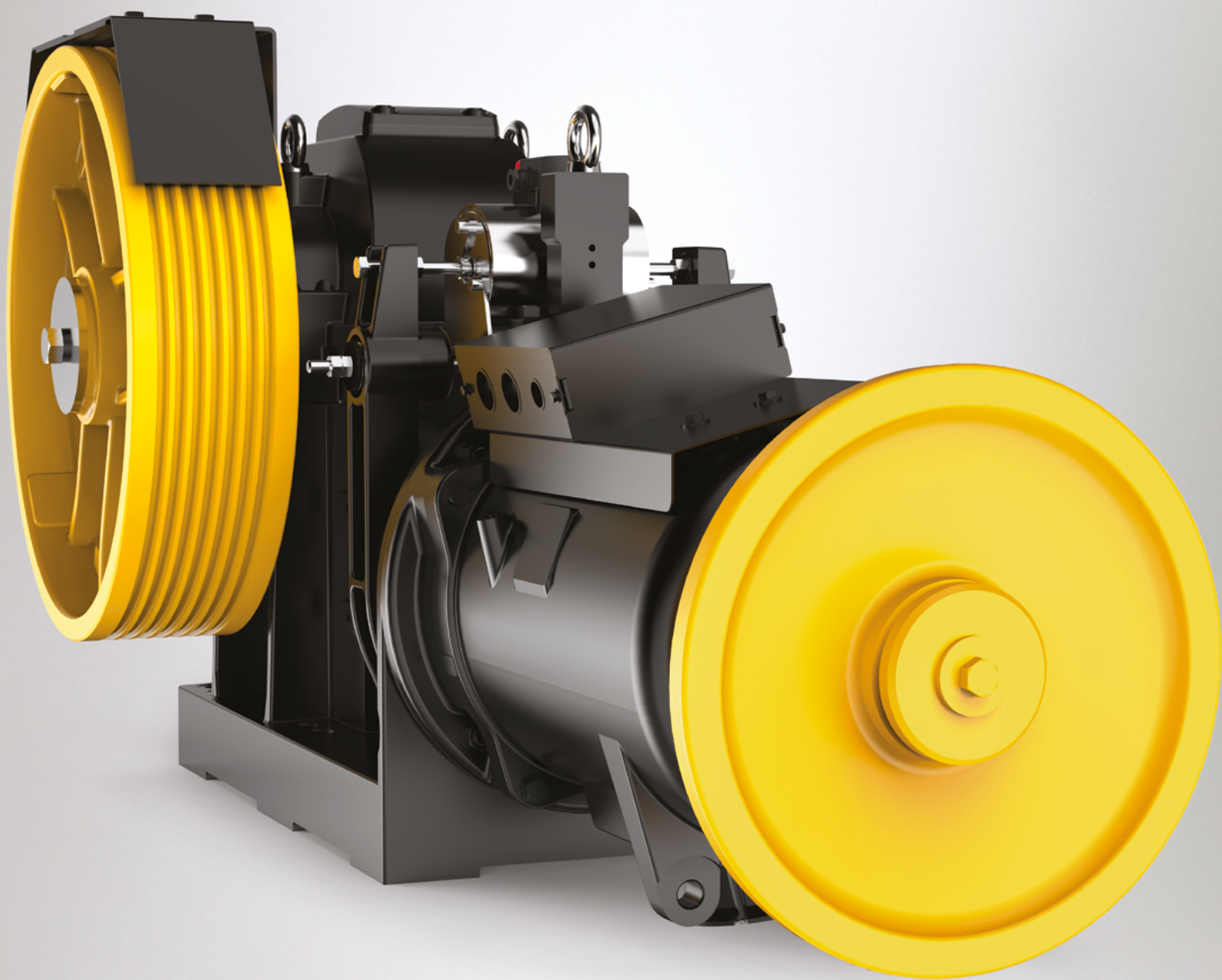

MR26

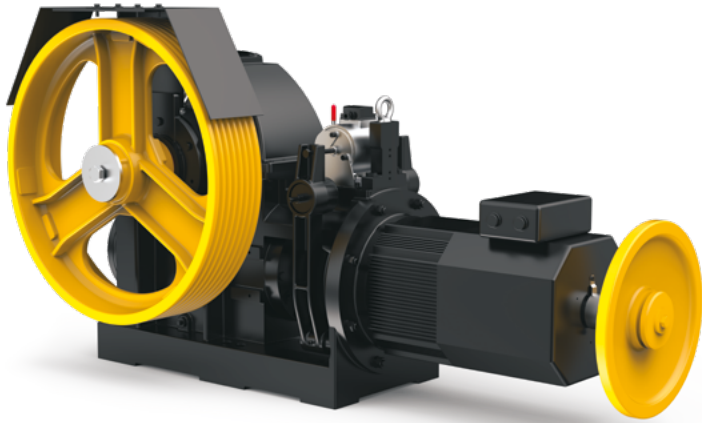

Max. Static Load MR26	64,7 kN - 6600 kg
Max. Static Load MR26TS	80,2 kN - 8175 kg
Power Range 50 Hz 4 poles VVVF	13,5 ÷ 43 kW
Power Range 50 Hz 4/16 poles	13,5 ÷ 30 kW
Power Range 33 Hz 4 poles	11 ÷ 29 kW
Power Range 50 Hz 6 poles VVVF	11 ÷ 29 kW (on request)
Power Range 60 Hz 4 poles VVVF	15 ÷ 47 kW
Power Range 60 Hz 4/16 poles	15 ÷ 33 kW
Ratio	1/72; 1/57; 1/44; 2/63; 2/45; 3/55
Geared Weight	1200 ÷ 1600 kg
Oil capacity	10,8 l

Geared machine Rh o Lh (from motor side) **Image ref. to Lh geared**

*The geared machine efficiency values are present above each "rated load" table
The motor efficiency values are present in the table "electric motor data"*

DIMENSIONS MR26

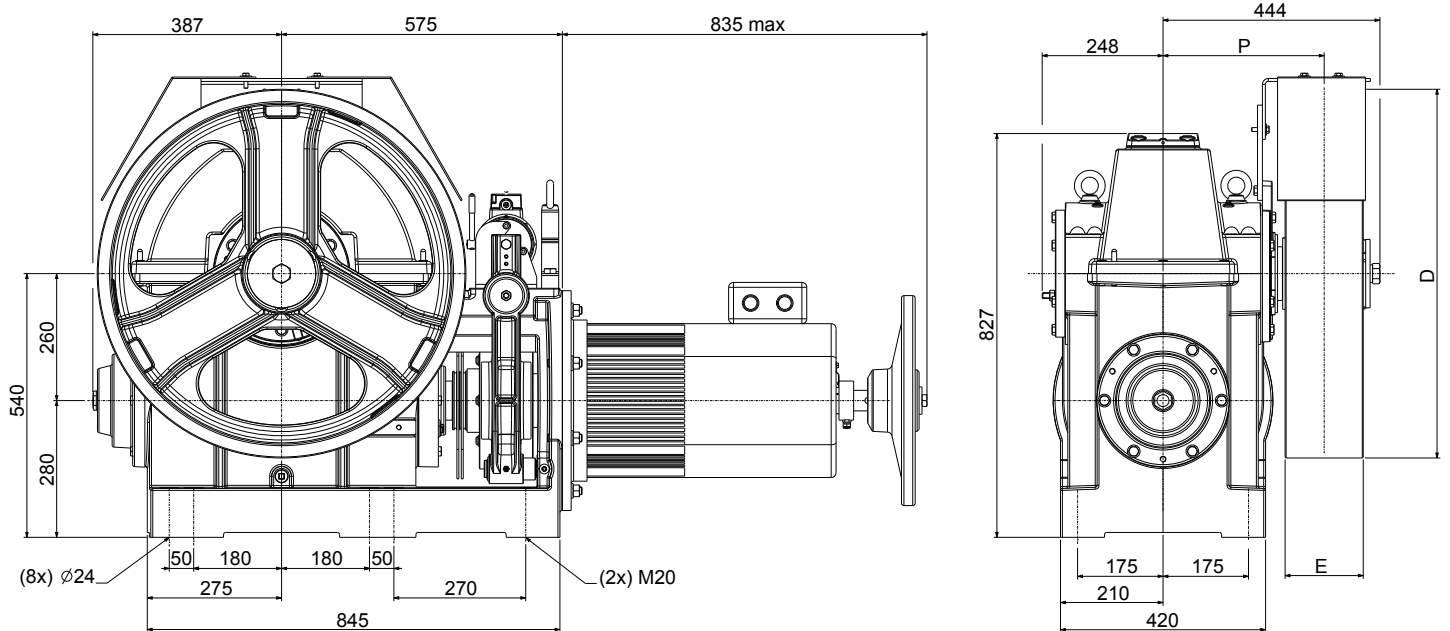

Wrapping System	Traction sheave		Dimension	Load*)
	D [mm]	E [mm]		
ESW	560	236	347	59 - 6000
	600	160		
CSW	650	160	330	64,7 - 6600
	690	160		
	750	160		
	800	160		

*) Max. static load on the slow shaft:
CSW: Conventional single wrap
ESW: Extended single wrap (patented)

Brake Electromagnet		
[V]	[A]	[W]
48	5,16	243
60	4,2	252
80	3,2	252
110	2,3	253
205	1,3	262

DIMENSIONS MR26TS

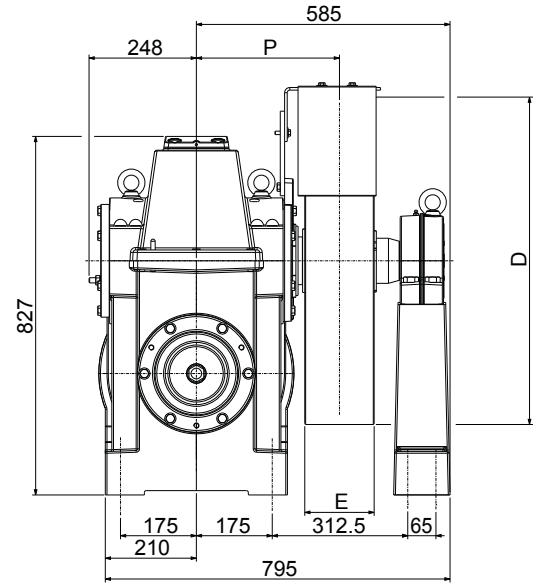
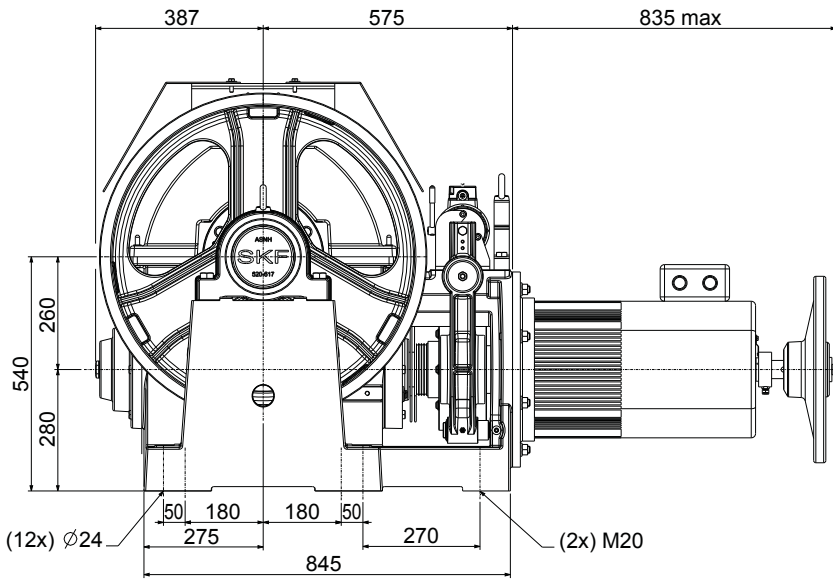

Wrapping System	Traction sheave		Dimension	Load*)
	D [mm]	E [mm]		
ESW	560	236	347	70 - 7150
	600	160		
CSW	650	160	330	80,2 ¹⁾ - 8175 ¹⁾ 70 ²⁾ - 7150 ²⁾
	690	160		
	750	160		
	800	160		

*) Max. static load on the slow shaft:

CSW: Conventional single wrap
 F = 80,2 kN¹⁾
 horizontal component not to exceed
 F = 70 kN²⁾

ESW: Extended single wrap (patented)

Brake Electromagnet		
[V]	[A]	[W]
48	5,16	243
60	4,2	252
80	3,2	252
110	2,3	253
205	1,3	262

Wrapping system		R.R.	Traction Sheave Ø	Speed syn.	Motor Output [kW]									
CSW	ESW	[i]	[mm]	[m/s]	VVVF AC2 13,5	VVVF AC2 16,5	VVVF AC2 20	VVVF AC2 25	VVVF AC2 30	VVVF 33	VVVF 37	VVVF 40	VVVF 43	
--	X	1/72	560	0,61	2175	2650	--	--	--	--	--	--	--	
X	--	1/72	600	0,65	2030	2615	2650	--	--	--	--	--	--	
X	--	1/72	650	0,71	1875	2410	2650	--	--	--	--	--	--	
X	--	1/72	690	0,75	1765	2270	2560	--	--	--	--	--	--	
--	X	1/57	560	0,77	1785	2305	2650	--	--	--	--	--	--	
X	--	1/72	750	0,82	1625	2090	2355	--	--	--	--	--	--	
X	--	1/57	600	0,83	1665	2155	2650	--	--	--	--	--	--	
X	--	1/72	800	0,87	1520	1960	2205	--	--	--	--	--	--	
X	--	1/57	650	0,90	1540	1985	2510	2650	--	--	--	--	--	
X	--	1/57	690	0,95	1450	1870	2365	2650	--	--	--	--	--	
--	X	1/44	560	1,00	1410	1820	2305	2650	--	--	--	--	--	
X	--	1/57	750	1,03	1335	1720	2175	2580	--	--	--	--	--	
X	--	1/44	600	1,07	1315	1700	2150	2650	--	--	--	--	--	
X	--	1/57	800	1,10	1250	1615	2040	2420	--	--	--	--	--	
X	--	1/44	650	1,16	1210	1570	1985	2580	2650	--	--	--	--	
X	--	1/44	690	1,23	1140	1480	1870	2430	2650	--	--	--	--	
X	--	1/44	750	1,34	1050	1360	1720	2235	2650	--	--	--	--	
--	X	2/63	560	1,40	1090	1400	1760	2270	2650	--	--	--	--	
X	--	1/44	800	1,43	985	1275	1615	2095	2485	--	--	--	--	
X	--	2/63	600	1,50	1015	1305	1640	2120	2600	2650	--	--	--	
X	--	2/63	650	1,62	940	1205	1515	1955	2400	2615	--	--	--	
X	--	2/63	690	1,72	885	1135	1425	1845	2260	2465	--	--	--	
X	--	2/63	750	1,87	815	1045	1310	1695	2080	2270	--	--	--	
--	X	2/45	560	1,95	770	995	1255	1630	2000	2225	2520	2650	--	
X	--	2/63	800	1,99	760	980	1230	1590	1950	2125	--	--	--	
X	--	2/45	600	2,09	720	925	1170	1520	1865	2075	2355	2565	2650	
X	--	2/45	650	2,27	665	855	1080	1400	1725	1915	2175	2365	2560	
--	X	3/55	560	2,40	635	815	1030	1340	1645	1830	2075	2260	2440	
X	--	2/45	690	2,41	625	805	1020	1320	1625	1805	2045	2230	2410	
X	--	3/55	600	2,57	590	765	965	1250	1535	1705	1935	2105	2280	
X	--	2/45	750	2,62	575	740	935	1215	1495	1660	1885	2050	2215	
X	--	3/55	650	2,78	545	705	890	1155	1415	1575	1785	1945	2105	
X	--	2/45	800	2,79	540	695	880	1140	1400	1555	1765	1920	2080	
X	--	3/55	690	2,96	515	665	835	1085	1335	1485	1685	1830	1980	
X	--	3/55	750	3,21	470	610	770	1000	1230	1365	1550	1685	1825	
X	--	3/55	800	3,43	445	570	720	935	1150	1280	1450	1580	1710	

R.R.		Max Output Torque	Geared Efficiency									
[i]	[Nm]	VVVF AC2 13,5	VVVF AC2 16,5	VVVF AC2 20	VVVF AC2 25	VVVF AC2 30	VVVF 33	VVVF 37	VVVF 40	VVVF 43		
1/72	5420	0,63	0,67	0,69	0,72	0,74	0,74	0,75	0,76	0,76		
1/57	5940	0,66	0,70	0,72	0,75	0,77	0,78	0,79	0,79	0,80		
1/44	6100	0,67	0,71	0,74	0,77	0,79	0,80	0,81	0,82	0,82		
2/63	5220	0,73	0,76	0,79	0,82	0,84	0,84	0,85	0,86	0,86		
2/45	5550	0,72	0,76	0,79	0,82	0,84	0,85	0,86	0,86	0,87		
3/55	5580	0,73	0,77	0,80	0,83	0,85	0,86	0,87	0,87	0,88		

Rated load values listed in the table include the weight of the ropes.
 To know the theoretical load, subtract the weight of the ropes.
 Position Of The Geared = Top Counterweight = 50% Plant efficiency = 0,80

60Hz										33Hz						
VVVF 1800 rpm 4 Poles AC2 1800/450 rpm 4/16 Poles										VVVF 1000 rpm 6 Poles						
Motor Output [kW]																
	VVVF AC2 15	VVVF AC2 18	VVVF AC2 22	VVVF AC2 27	VVVF AC2 33	VVVF 36	VVVF 40	VVVF 44	VVVF 47		VVVF 11	VVVF 13,5	VVVF 16,5	VVVF 20	VVVF 25	VVVF 29
Speed syn.	Max Rated Load									Speed syn.	Max Rated Load					
[m/s]	[kg]	[kg]	[kg]	[kg]	[kg]	[kg]	[kg]	[kg]	[kg]	[m/s]	[kg]	[kg]	[kg]	[kg]	[kg]	[kg]
0,73	2035	2455	--	--	--	--	--	--	--	0,41	2637	2650	--	--	--	--
0,79	1895	2290	--	--	--	--	--	--	--	0,44	2635	2650	--	--	--	--
0,85	1750	2115	--	--	--	--	--	--	--	0,47	2430	2650	--	--	--	--
0,90	1650	1995	--	--	--	--	--	--	--	0,50	2290	2560	--	--	--	--
0,93	1655	2090	2650	--	--	--	--	--	--	0,51	2325	2650	--	--	--	--
0,98	1515	1835	--	--	--	--	--	--	--	0,55	2105	2355	--	--	--	--
0,99	1545	1950	2490	2650	--	--	--	--	--	0,55	2170	2650	--	--	--	--
1,05	1420	1720	--	--	--	--	--	--	--	0,58	1975	2205	--	--	--	--
1,07	1425	1800	2295	2500	--	--	--	--	--	0,60	2005	2565	2650	--	--	--
1,14	1340	1695	2165	2355	--	--	--	--	--	0,63	1890	2415	2650	--	--	--
1,20	1315	1665	2125	2650	--	--	--	--	--	0,67	1840	2355	2650	--	--	--
1,24	1235	1560	1990	2170	--	--	--	--	--	0,69	1735	2220	2580	--	--	--
1,29	1230	1550	1980	2520	2620	--	--	--	--	0,71	1715	2200	2650	--	--	--
1,32	1155	1460	1865	2030	--	--	--	--	--	0,73	1630	2085	2420	--	--	--
1,39	1135	1430	1830	2325	2415	--	--	--	--	0,77	1585	2030	2565	2650	--	--
1,48	1070	1350	1725	2190	2275	--	--	--	--	0,82	1490	1910	2415	2650	--	--
1,61	985	1240	1585	2015	2095	--	--	--	--	0,89	1370	1760	2225	2650	--	--
1,68	1020	1275	1620	2045	2350	--	--	--	--	0,93	1410	1795	2260	2650	--	--
1,71	920	1165	1485	1890	1965	--	--	--	--	0,95	1285	1650	2085	2485	--	--
1,80	950	1190	1510	1910	2195	--	--	--	--	1,00	1315	1675	2110	2610	2650	--
1,94	875	1100	1395	1765	2025	--	--	--	--	1,08	1215	1545	1945	2410	2615	--
2,06	825	1035	1315	1660	1905	--	--	--	--	1,15	1145	1455	1835	2270	2465	--
2,24	760	950	1205	1525	1755	--	--	--	--	1,25	1055	1340	1685	2090	2270	--
2,35	710	895	1145	1455	1830	2015	2265	2510	2650	1,30	1005	1280	1620	2010	2570	2650
2,39	710	890	1130	1430	1645	--	--	--	--	1,33	985	1255	1580	1960	2125	--
2,51	660	835	1070	1360	1705	1880	2110	2345	2520	1,40	935	1195	1510	1875	2395	2650
2,72	610	770	985	1255	1575	1735	1950	2165	2325	1,51	865	1105	1395	1730	2210	2600
2,88	590	745	950	1205	1510	1665	1870	2075	2225	1,60	825	1055	1330	1650	2110	2480
2,89	575	725	930	1180	1485	1635	1835	2040	2190	1,61	815	1040	1315	1630	2085	2445
3,08	550	695	885	1125	1410	1555	1745	1935	2080	1,71	770	985	1240	1540	1970	2315
3,14	530	670	855	1085	1365	1505	1690	1875	2015	1,75	750	955	1205	1500	1915	2250
3,34	510	640	815	1040	1300	1435	1610	1785	1920	1,86	710	910	1145	1425	1820	2135
3,35	495	625	800	1020	1280	1410	1585	1755	1890	1,86	700	895	1130	1405	1795	2110
3,55	480	605	770	975	1225	1350	1515	1680	1805	1,97	670	855	1080	1340	1715	2010
3,86	440	555	710	900	1130	1240	1395	1545	1660	2,14	615	785	995	1235	1575	1850
4,11	415	520	665	845	1055	1165	1310	1450	1560	2,28	575	740	930	1155	1480	1735

60Hz										33Hz						
Motor Output [kW]																
	VVVF AC2 15	VVVF AC2 18	VVVF AC2 22	VVVF AC2 27	VVVF AC2 33	VVVF 36	VVVF 40	VVVF 44	VVVF 47		VVVF 11	VVVF 13,5	VVVF 16,5	VVVF 20	VVVF 25	VVVF 29
Max Output Torque	Geared Efficiency									Max Output Torque	Geared Efficiency					
[Nm]										[Nm]						
4220	0,64	0,67	0,70	0,72	0,74	0,74	0,75	0,76	0,76	5420	0,67	0,70	0,72	0,74	0,75	0,76
4990	0,66	0,69	0,72	0,75	0,77	0,78	0,79	0,79	0,80	5940	0,70	0,73	0,75	0,77	0,79	0,80
4820	0,68	0,71	0,75	0,77	0,79	0,80	0,81	0,82	0,82	6100	0,72	0,75	0,77	0,79	0,81	0,82
4040	0,73	0,77	0,79	0,82	0,84	0,85	0,85	0,86	0,86	5220	0,77	0,80	0,82	0,84	0,86	0,87
4760	0,72	0,75	0,79	0,82	0,84	0,85	0,86	0,86	0,87	5550	0,77	0,80	0,82	0,84	0,86	0,87
4380	0,73	0,77	0,80	0,83	0,85	0,86	0,87	0,87	0,88	5580	0,77	0,81	0,83	0,85	0,87	0,88

50Hz														
VVVF 1500 rpm 4 Poles AC2 1500/375 rpm 4/16 Poles														
Asynchronous Rated Power [kW]														
	VVVV 13,5	VVVV 16,5	VVVV 20	VVVV 25	VVVV 30	VVVV 33	VVVV 37	VVVV 40	VVVV 43	AC2 13,5	AC2 16,5	AC2 20	AC2 25	AC2 30
Motor Parameters														
Rated Voltage (star connection) ^{(1) (3)} [V]	400	400	400	400	400	400	400	400	400	400	400	400	400	400
Frequency [Hz]	50	50	50	50	50	50	50	50	50	50	50	50	50	50
Synchronous Speed [rpm]	1500	1500	1500	1500	1500	1500	1500	1500	1500	1500/375	1500/375	1500/375	1500/375	1500/375
Asynchronous Speed [rpm]	1464	1460	1462	1459	1459	1461	1456	1460	1457	1340/280	1340/270	1365/275	1384/300	1350/305
Rated Current ⁽²⁾ [A]	27	34	42	50	59	66	74	80	86	39/24	42/27	47/33	59/39	69/51
Rated Torque [Nm]	88	108	131	164	196	216	243	262	282	96	118	140	173	212
Cos φ Power Factor []	0,84	0,83	0,82	0,84	0,82	0,84	0,83	0,84	0,85	--	--	--	--	--
Starting Current [A]	128	150	150	193	235	264	296	325	325	113	144	160	207	245
Starting Torque [Nm]	220	270	330	410	510	550	630	700	700	229	280	329	419	514
Duty Cycle [%]	60	60	60	60	60	60	60	60	60	30+10	30+10	30+10	30+10	30+10
Starts per Hour [s/h]	240	240	240	240	240	240	240	240	240	180	180	180	180	180
Insulation Class []	F	F	F	F	F	F	F	F	F	F	F	F	F	F
Degree of Protection IP []	IP21	IP21	IP21	IP21	IP21	IP21	IP21	IP21	IP21	IP21	IP21	IP21	IP21	IP21

(1) The motors are standard supplied with star connection (Y), the customer can arrange a delta connection (Δ).

(2) The indicated current values are related to 400V voltage. For current values with delta connection, multiply the values by 1,732.

Motor are manufactured for 50Hz. Inverter must assure those frequencies and voltages independently from the net frequency.

(3) The standard supply voltage is suitable for 380-400V/220-230V power supplies.

The geared machine is fan cooled with a fan mounted on the motor shaft or force ventilated with external fan 1 ~ 220 ... 240V 50/60Hz

60Hz														
VVVF 1800 rpm 4 Poles AC2 1800/450 rpm 4/16 Poles														
Asynchronous Rated Power [kW]														
	VVVV 15	VVVV 18	VVVV 22	VVVV 27	VVVV 33	VVVV 36	VVVV 40	VVVV 44	VVVV 47	AC2 15	AC2 18	AC2 22	AC2 27	AC2 33
Motor Parameters														
Rated Voltage (star connection) ^{(1) (3)} [V]	400	400	400	400	400	400	400	400	400	400	400	400	400	400
Frequency [Hz]	60	60	60	60	60	60	60	60	60	60	60	60	60	60
Synchronous Speed [rpm]	1800	1800	1800	1800	1800	1800	1800	1800	1800	1800/450	1800/450	1800/450	1800/450	1800/450
Asynchronous Speed [rpm]	1755	1755	1735	1750	1750	1750	1747	1747	1747	1620/350	1670/320	1660/345	1675/365	1680/380
Rated Current ⁽²⁾ [A]	38	46	57	59	66	72	80	87	93	42/25	50/33	59/41	63/40	71/52
Rated Torque [Nm]	82	98	121	149	182	196	219	240	257	88	103	126	154	188
Cos φ Power Factor []	0,87	0,88	0,88	0,88	0,86	0,87	0,84	0,81	0,83	--	--	--	--	--
Starting Current [A]	143	175	210	230	250	275	--	--	--	130	166	185	220	261
Starting Torque [Nm]	209	250	298	410	510	--	--	--	--	211	250	298	358	430
Duty Cycle [%]	60	60	60	60	60	60	60	60	60	30+10	30+10	30+10	30+10	30+10
Starts per Hour [s/h]	240	240	240	240	240	240	240	240	240	180	180	180	180	180
Insulation Class []	F	F	F	F	F	F	F	F	F	F	F	F	F	F
Degree of Protection IP []	IP21	IP21	IP21	IP21	IP21	IP21	IP21	IP21	IP21	IP21	IP21	IP21	IP21	IP21

(1) The motors are standard supplied with star connection (Y), the customer can arrange a delta connection (Δ).

(2) The indicated current values are related to 400V voltage. For current values with delta connection, multiply the values by 1,732.

Motor are manufactured for 60Hz. Inverter must assure those frequencies and voltages independently from the net frequency.

(3) The standard supply voltage is suitable for 380-400V/220-230V power supplies.

The geared machine is fan cooled with a fan mounted on the motor shaft or force ventilated with external fan 1 ~ 220 ... 240V 50/60Hz

		33Hz					
		VVVF 1000 rpm 4 Poles					
		Asynchronous Rated Power [kW]					
		VVVF 11	VVVF 13,5	VVVF 16,5	VVVF 20	VVVF 25	VVVF 29
		Motor Parameters					
Rated Voltage (star connection) ^{(1) (3)}	[V]	400	400	400	400	400	400
Frequency	[Hz]	33	33	33	33	33	33
Synchronous Speed	[rpm]	990	990	990	990	990	990
Asynchronous Speed	[rpm]	959	958	956	954	943	948
Rated Current ⁽²⁾	[A]	24	29	36	43	51	60
Rated Torque	[Nm]	110	135	165	200	253	292
Cos φ Power Factor	[]	0,81	0,82	0,81	0,81	0,85	0,83
Starting Current	[A]	111	135	167	205	224	242
Starting Torque	[Nm]	290	340	415	500	630	690
Duty Cycle	[%]	60	60	60	60	60	60
Starts per Hour	[s/h]	240	240	240	240	240	240
Insulation Class	[]	F	F	F	F	F	F
Degree of Protection IP	[]	IP21	IP21	IP21	IP21	IP21	IP21

(1) The motors are standard supplied with star connection (Y), the customer can arrange a delta connection (Δ).

(2) The indicated current values are related to 400V voltage. For current values with delta connection, multiply the values by 1,732. Motor are manufactured for 50Hz. Inverter must assure those frequencies and voltages independently from the net frequency.

(3) The standard supply voltage is suitable for 380-400V/220-230V power supplies.

The geared machine is fan cooled with a fan mounted on the motor shaft or force ventilated with external fan 1 ~ 220 ... 240V 50/60Hz

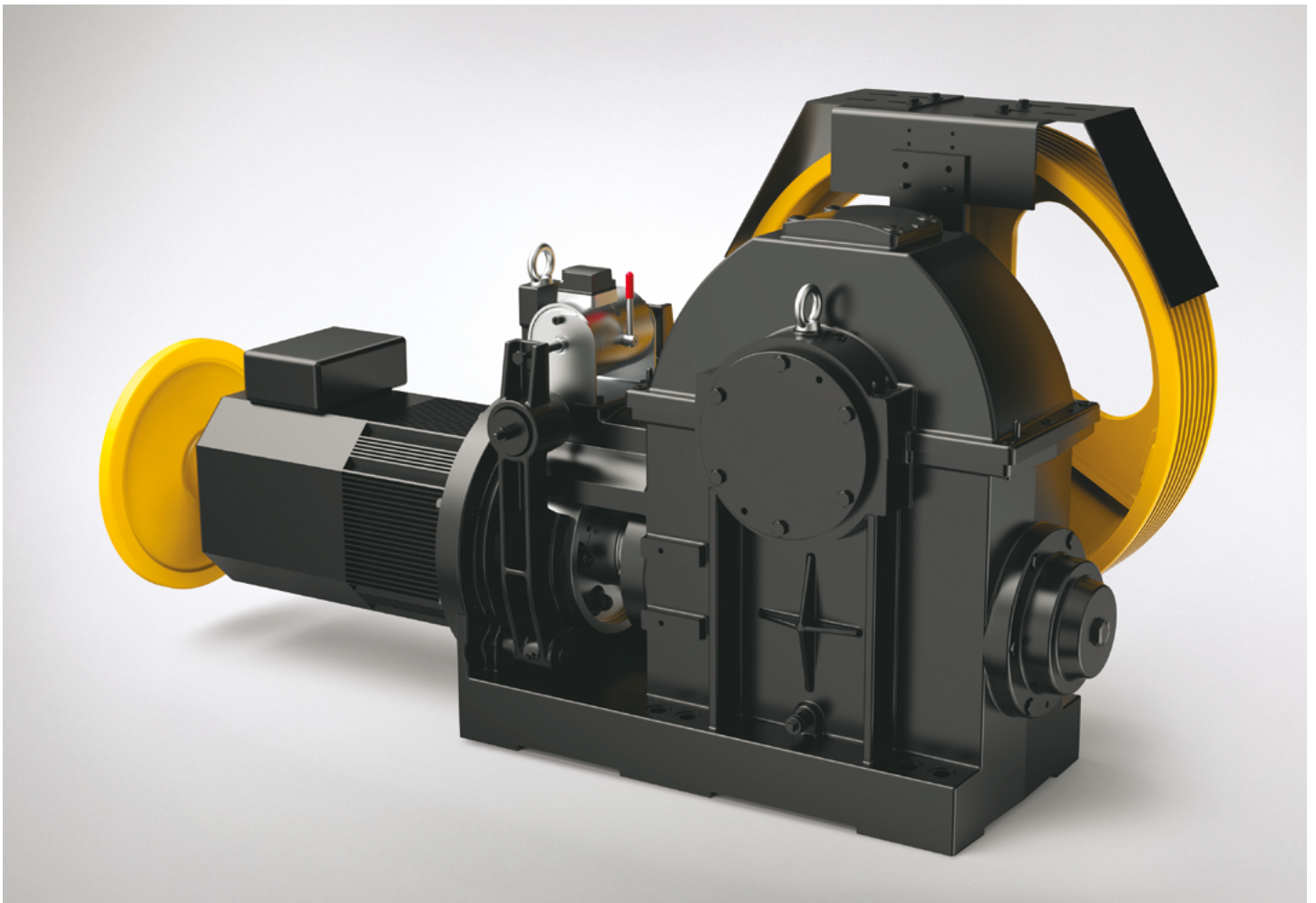

Wrapping System	Traction sheave		Max n° Grooves x D	Grooves Pitch	
	D [mm]	E [mm]	n° x mm	l [mm]	
ESW	560	236	8xD13	30	
	600	160	9xD10	16	
	600	160	8xD11	18	
	600	160	8xD12	18	
	600	160	8xD13	19	
	600	160	6xD14	22	
	600	160	6xD15	22	
	650	160	9xD10	16	
	650	160	8xD11	18	
	650	160	8xD12	18	
	650	160	8xD13	19	
	650	160	6xD14	22	
	650	160	6xD15	22	
	650	160	6xD16	22	
	690	160	9xD10	16	
	690	160	8xD11	18	
	690	160	8xD12	18	
	690	160	8xD13	19	
	690	160	6xD14	22	
	690	160	6xD15	22	
	690	160	6xD16	22	
	CSW	750	160	9xD10	16
		750	160	8xD11	18
		750	160	8xD12	18
		750	160	8xD13	19
		750	160	6xD14	22
		750	160	6xD15	22
750		160	6xD16	22	
800		160	9xD10	16	
800		160	8xD11	18	
800		160	8xD12	18	
800		160	8xD13	19	
800		160	6xD14	22	
800		160	6xD15	22	
800		160	6xD16	22	

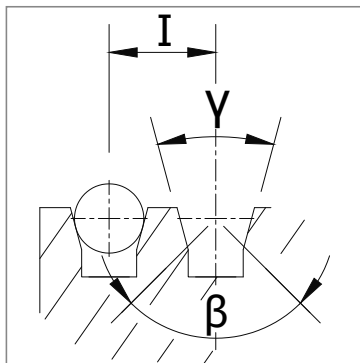
VCI

V grooves with undercut

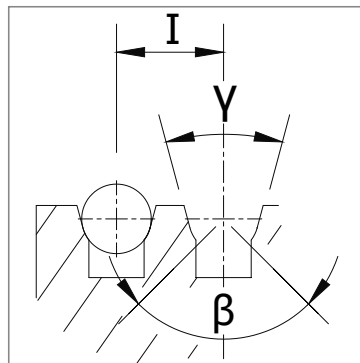
UCI

U grooves with undercut

γ = groove angle
 β = undercut angle
 I = grooves pitch

BEDPLATE | TOP MACHINE WITHOUT DIVERTING PULLEY FOR CSW WINDING (SHORT)

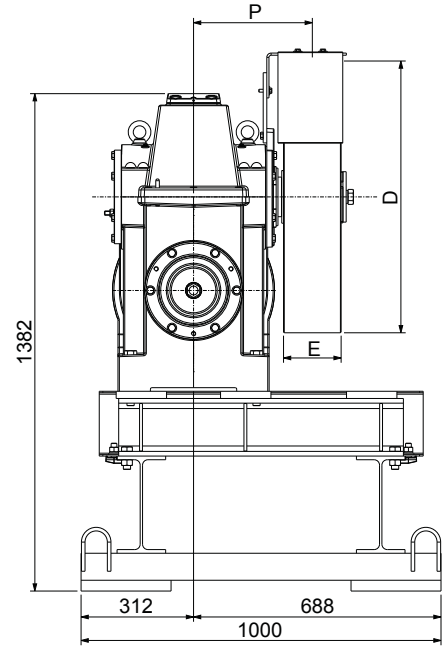
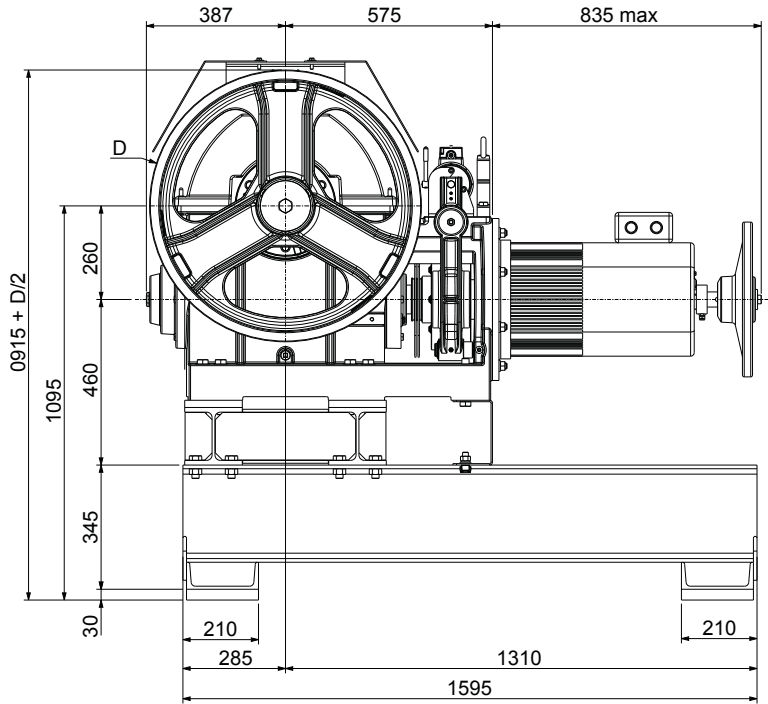

MR26 XTE2959 Weight of machine bedplate: 313 kg.
 MR26TS XTE0037 for top machine (included vibration dampers); XTE0069 for bottom/on side machine (included vibration dampers)
 Weight of machine bedplate: 165 kg (Bedplate + vibration dampers)
 Note: Machine room floor thickness min. 250 mm.

BEDPLATE | TOP MACHINE WITH DIVERTING PULLEY FOR CSW WINDING (SHORT)

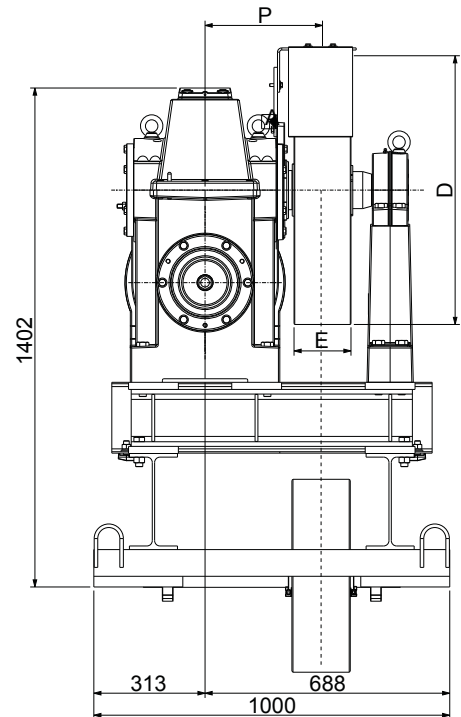
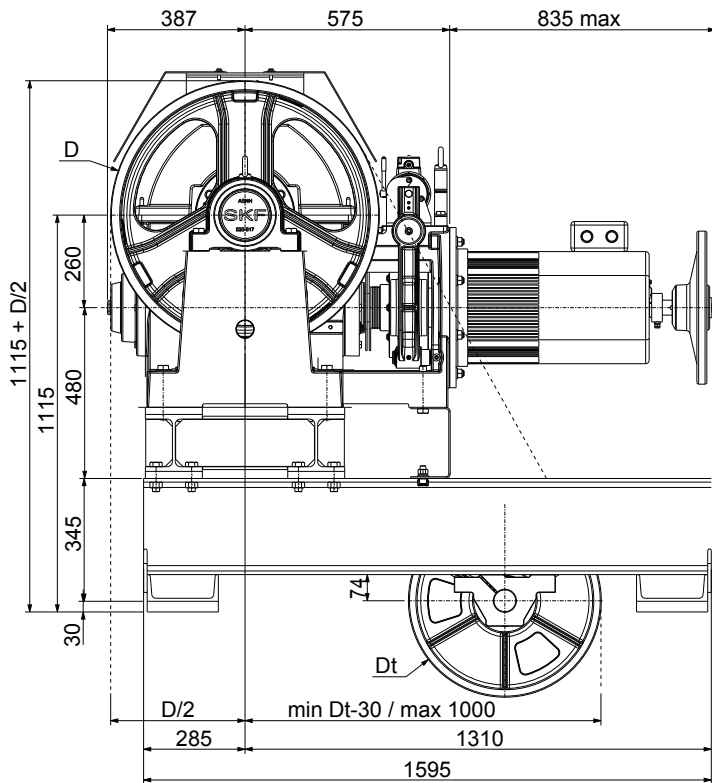

MR26 XTE2961 Weight of machine bedplate: 465 kg.
 MR26TS XTE0041 (included vibration dampers) Weight of machine bedplate: 534 kg (bedplate + diverting pulley + vibration dampers)
 Note: Machine room floor thickness min. 250 mm. (without diverting pulley)

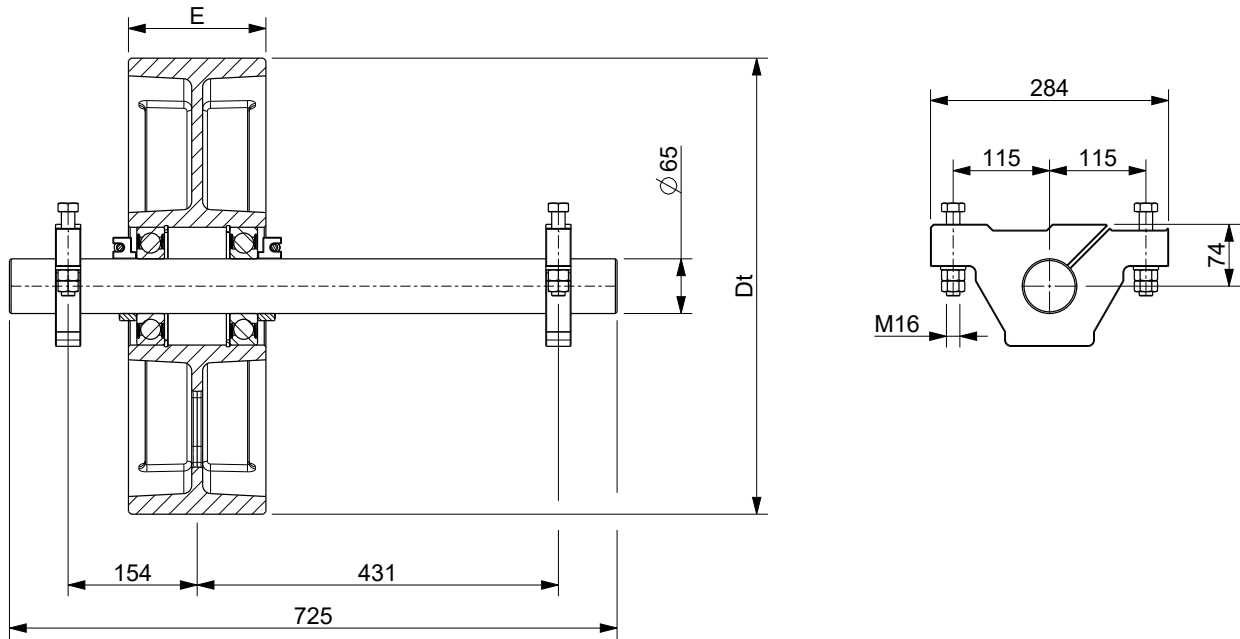

Diverting Pulley		Max n°Grooves x D	Grooves Pitch l [mm]	Distance X [mm]	Length L [mm]	Force F Max [kN]
D [mm]	E [mm]					
534	124	7xD10	16	72+90	725	23
		6xD12	18	72+90	725	23
		6xD13	19	72+90	725	23
	164	10xD10	16	72+90	725	24,2
		8xD12	18	72+90	725	24,2
		8xD13	19	72+90	725	24,2
656	186	11xD10	16	122	725	24,9
		10xD12	18	122	725	24,9
		9xD13	19	122	725	24,9
		8xD16	22	122	725	24,9

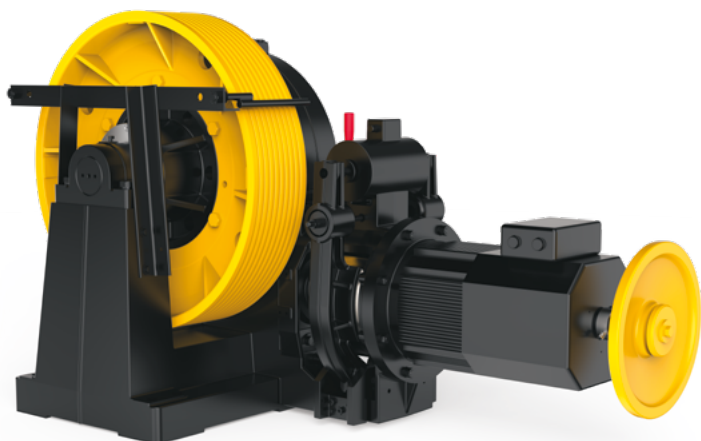

Max. Static Load	139,3 kN - 14200 kg
Power Range 50 Hz 4 poles VVVF	25 ÷ 90 kW
Power Range 50 Hz 4/16 poles	25 ÷ 43 kW
Power Range 33 Hz 4 poles	20 ÷ 36 kW
Power Range 50 Hz 6 poles VVVF	20 ÷ 36 kW (on request)
Power Range 60 Hz 4 poles VVVF	27 ÷ 100 kW
Power Range 60 Hz 4/16 poles	27 ÷ 44 kW
Ratio	1/58; 1/53; 2/73;
	2/60; 3/70; 3/53
Geared Weight	1600 ÷ 1900 kg
Oil capacity	23,5 l
Geared machine Rh o Lh (from motor side)	Image ref. to Lh geared

The geared machine efficiency values are present above each "rated load" table
 The motor efficiency values are present in the table "electric motor data"

DIMENSIONS

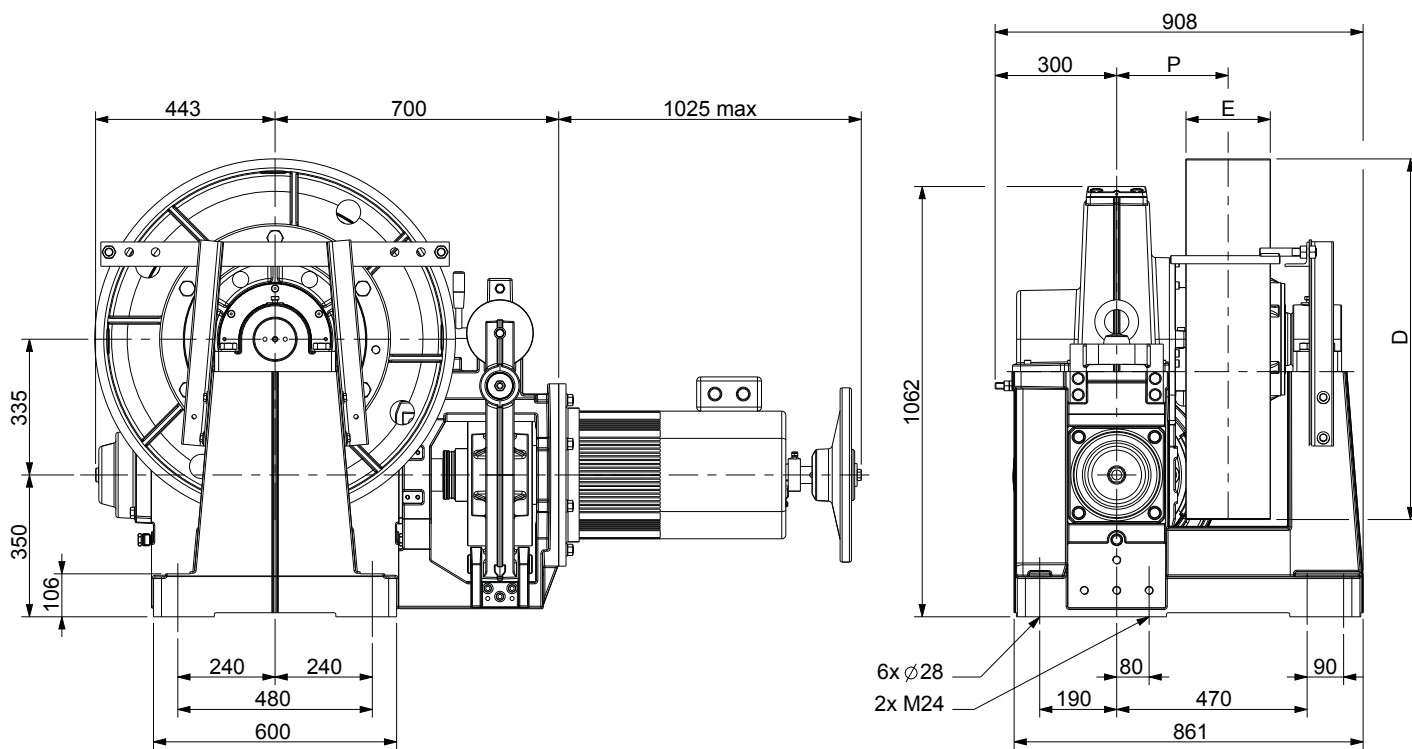

Wrapping System	Traction sheave		Dimension	Load*)
	D [mm]	E [mm]	P [mm]	F [kN - kg]
CSW	690	208	275	139.3 ¹⁾ - 14200 ¹⁾ 70 ²⁾ - 7150 ²⁾
	770	252		
	800	208		
	885	208		

*) Max. static load on the slow shaft:
 CSW: Conventional single wrap
 F= 139,3 kN¹⁾
 horizontal component not to exceed
 F= 70 kN²⁾

**) Diverting pulley must not be located on this (brake) side, rope must go straight down.

Brake Electromagnet		
[V]	[A]	[W]
48	4,9	235
60	4,5	270
80	3,2	256
110	2,9	319
205	1,6	320

50Hz												
VVVF 1500 rpm 4 Poles AC2 1500/375 rpm 4/16 Poles												
Motor Output [kW]												
		Max Rated Load										
		VVVF AC2 25	VVVF AC2 30	VVVF AC2 33	VVVF AC2 37	VVVF AC2 40	VVVF AC2 43	VVVF 55	VVVF 75	VVVF 90		
R.R.	Traction Sheave Ø	Speed syn.										
[i]	[mm]	[m/s]	[kg]	[kg]	[kg]	[kg]	[kg]	[kg]	[kg]	[kg]	[kg]	
1/58	690	0,93	2975	3700	4100	--	--	--	--	--	--	
1/53	690	1,02	2740	3405	3805	4100	--	--	--	--	--	
1/58	770	1,04	2665	3315	3700	4100	--	--	--	--	--	
1/58	800	1,08	2565	3190	3565	4065	4100	--	--	--	--	
1/53	770	1,14	2455	3050	3410	3885	4100	--	--	--	--	
1/53	800	1,19	2365	2935	3280	3740	4085	4100	--	--	--	
1/58	885	1,20	2320	2880	3220	3670	4010	--	--	--	--	
1/53	885	1,31	2135	2655	2965	3380	3690	4000	4100	--	--	
2/73	690	1,48	2045	2530	2820	3210	3500	3795	4100	--	--	
2/73	770	1,66	1830	2265	2530	2875	3140	3400	4100	--	--	
2/73	800	1,72	1765	2180	2435	2770	3020	3270	4100	--	--	
2/60	690	1,81	1645	2040	2280	2600	2840	3075	4030	4100	--	
2/73	885	1,90	1595	1970	2200	2500	2730	2955	3865	3905	--	
2/60	770	2,02	1475	1830	2045	2330	2545	2755	3615	4100	--	
2/60	800	2,09	1415	1760	1965	2240	2445	2655	3475	4100	--	
2/60	885	2,32	1280	1590	1780	2025	2210	2400	3145	4035	--	
3/70	690	2,32	1315	1625	1815	2070	2255	2445	3200	4100	--	
3/70	770	2,59	1175	1460	1625	1855	2020	2190	2870	3995	4100	
3/70	800	2,69	1130	1405	1565	1785	1945	2110	2760	3845	4100	
3/70	885	2,98	1025	1270	1415	1610	1760	1905	2495	3475	3820	
3/53	690	3,07	995	1235	1380	1575	1720	1865	2440	3405	4100	
3/53	770	3,42	890	1110	1240	1410	1540	1670	2190	3050	3700	
3/53	800	3,56	860	1065	1190	1360	1480	1605	2105	2935	3560	
3/53	885	3,93	775	965	1075	1225	1340	1450	1905	2655	3220	

50Hz											
Motor Output [kW]											
		VVVF AC2 25	VVVF AC2 30	VVVF AC2 33	VVVF AC2 37	VVVF AC2 40	VVVF AC2 43	VVVF 55	VVVF 75	VVVF 90	
R.R.	Max Output Torque	Geared Efficiency									
[i]	[Nm]										
1/58	10880	0,72	0,74	0,75	0,77	0,77	0,78	0,80	0,82	0,83	
1/53	11500	0,72	0,75	0,76	0,77	0,78	0,79	0,81	0,82	0,83	
2/73	10600	0,78	0,81	0,82	0,83	0,84	0,84	0,86	0,88	0,89	
2/60	10950	0,77	0,79	0,80	0,82	0,83	0,83	0,85	0,87	0,88	
3/70	10370	0,79	0,81	0,82	0,84	0,84	0,85	0,87	0,89	0,90	
3/53	10570	0,79	0,82	0,83	0,84	0,85	0,86	0,88	0,90	0,91	

Rated load values listed in the table include the weight of the ropes.

To know the theoretical load, subtract the weight of the ropes.

Position Of The Geared = Top Counterweight = 50% Plant efficiency = 0,80

		60Hz										33Hz					
		VVVF 1800 rpm 4 Poles AC2 1800/450 rpm 4/16 Poles										VVVF 1000 rpm 6 Poles					
		Motor Output [kW]															
		VVVF AC2 27	VVVF AC2 33	VVVF AC2 36	VVVF AC2 40	VVVF AC2 44	VVVF 47	VVVF 60	VVVF 90	VVVF 100							
R.R.	Traction Sheave Ø	Speed syn.	Max Rated Load									Speed syn.	Max Rated Load				
[i]	[mm]	[m/s]	[kg]	[kg]	[kg]	[kg]	[kg]	[kg]	[kg]	[kg]	[m/s]	[kg]	[kg]	[kg]	[kg]	[kg]	
1/58	690	1,12	2710	3435	3800	3810	--	--	--	--	0,62	3720	4100	--	--	--	
1/53	690	1,23	2490	3155	3490	3930	3975	--	--	--	0,68	3415	4100	--	--	--	
1/58	770	1,25	2430	3080	3405	3410	--	--	--	--	0,70	3330	4100	--	--	--	
1/58	800	1,30	2340	2965	3275	3285	--	--	--	--	0,72	3205	4100	--	--	--	
1/53	770	1,37	2235	2830	3125	3525	3560	--	--	--	0,76	3060	3955	4100	--	--	
1/53	800	1,42	2150	2720	3010	3390	3425	--	--	--	0,79	2945	3805	4100	--	--	
1/58	885	1,44	2115	2680	2960	2970	--	--	--	--	0,80	2900	3745	4075	--	--	
1/53	885	1,57	1940	2460	2720	3065	3095	--	--	--	0,87	2665	3440	4060	4100	--	
2/73	690	1,78	1855	2345	2585	2910	3235	3475	3710	--	0,99	2545	3270	3855	4100	--	
2/73	770	1,99	1665	2100	2315	2610	2900	3115	3325	--	1,10	2280	2930	3455	3845	4100	
2/73	800	2,07	1600	2020	2230	2510	2790	3000	3200	--	1,15	2195	2820	3325	3700	4100	
2/60	690	2,17	1490	1890	2090	2355	2620	2820	3680	3910	1,20	2045	2640	3120	3475	3955	
2/73	885	2,29	1450	1825	2015	2270	2520	2710	2890	--	1,27	1985	2550	3005	3345	3800	
2/60	770	2,42	1335	1695	1870	2110	2345	2525	3300	3505	1,34	1830	2365	2795	3115	3545	
2/60	800	2,51	1285	1630	1800	2030	2260	2430	3175	3375	1,40	1765	2280	2690	3000	3410	
2/60	885	2,78	1160	1475	1630	1835	2040	2195	2870	3050	1,54	1595	2060	2430	2710	3085	
3/70	690	2,79	1180	1495	1655	1865	2075	2230	2910	3950	1,55	1630	2100	2480	2760	3140	
3/70	770	3,11	1060	1340	1480	1670	1860	2000	2610	3540	1,73	1460	1885	2220	2475	2815	
3/70	800	3,23	1020	1290	1425	1605	1790	1925	2510	3405	1,80	1405	1810	2140	2380	2705	
3/70	885	3,57	920	1165	1290	1450	1615	1740	2270	3080	1,99	1270	1640	1930	2155	2445	
3/53	690	3,68	905	1150	1270	1430	1590	1710	2230	3435	2,04	1240	1600	1890	2105	2395	
3/53	770	4,11	810	1030	1135	1280	1425	1530	2000	3080	2,28	1110	1435	1695	1885	2145	
3/53	800	4,27	780	990	1095	1230	1370	1475	1925	2965	2,37	1070	1380	1630	1815	2065	
3/53	885	4,72	705	895	990	1115	1240	1335	1740	2680	2,62	965	1245	1475	1640	1865	

		60Hz										33Hz				
		Motor Output [kW]														
		VVVF AC2 27	VVVF AC2 33	VVVF AC2 36	VVVF AC2 40	VVVF AC2 44	VVVF 47	VVVF 60	VVVF 90	VVVF 100						
R.R.	Max Output Torque	Geared Efficiency									Max Output Torque	Geared Efficiency				
[i]	[Nm]										[Nm]					
1/58	8060	0,73	0,75	0,76	0,77	0,78	0,79	0,81	0,83	0,83	11060	0,75	0,77	0,78	0,79	0,80
1/53	8410	0,73	0,76	0,77	0,78	0,79	0,79	0,81	0,83	0,84	11500	0,75	0,78	0,79	0,80	0,81
2/73	7850	0,79	0,82	0,82	0,84	0,84	0,85	0,87	0,89	0,89	10600	0,81	0,83	0,85	0,86	0,86
2/60	8280	0,77	0,80	0,81	0,82	0,83	0,84	0,86	0,88	0,88	11370	0,79	0,82	0,83	0,84	0,85
3/70	8360	0,79	0,82	0,83	0,84	0,85	0,85	0,87	0,89	0,90	10820	0,81	0,84	0,85	0,86	0,87
3/53	7680	0,80	0,83	0,84	0,85	0,86	0,86	0,88	0,91	0,91	10990	0,82	0,84	0,86	0,87	0,88

		50Hz														
		VVVF 1500 rpm 4 Poles AC2 1500/375 rpm 4/16 Poles														
		Asynchronous Rated Power [kW]														
		VVVF 25	VVVF 30	VVVF 33	VVVF 37	VVVF 40	VVVF 43	VVVF 55	VVVF 75	VVVF 90	AC2 25	AC2 30	AC2 33	AC2 37	AC2 40	AC2 43
		Motor Parameters														
Rated Voltage (star connection) ^{(1) (3)}	[V]	400	400	400	400	400	400	400	400	400	400	400	400	400	400	400
Frequency	[Hz]	50	50	50	50	50	50	50	50	50	50	50	50	50	50	50
Synchronous Speed	[rpm]	1500	1500	1500	1500	1500	1500	1500	1500	1500	1500/375	1500/375	1500/375	1500/375	1500/375	1500/375
Asynchronous Speed	[rpm]	1459	1459	1461	1456	1460	1457	1471	1461	1465	1384/300	1350/305	1370/290	1370/300	1380/315	1370/300
Rated Current ⁽²⁾	[A]	49	59	66	74	80	86	99	130	156	59/39	69/51	73/55	82/55	88/62	95/63
Rated Torque	[Nm]	164	196	216	243	262	282	357	490	587	173	212	230	258	178	300
Cos φ Power Factor	[]	0,84	0,82	0,84	0,83	0,84	0,85	0,89	0,9	0,91	--	--	--	--	--	--
Starting Current	[A]	193	235	264	296	325	325	277	365	468	207	245	275	350	314	355
Starting Torque	[Nm]	410	510	550	630	700	700	821	1078	1291	419	514	570	639	667	745
Duty Cycle	[%]	60	60	60	60	60	60	40	40	40	30+10	30+10	30+10	30+10	30+10	30+10
Starts per Hour	[s/h]	240	240	240	240	240	240	240	240	240	180	180	180	180	180	180
Insulation Class	[]	F	F	F	F	F	F	F	F	F	F	F	F	F	F	F
Degree of Protection IP	[]	IP21	IP21	IP21	IP21	IP21	IP21	IP21	IP21	IP21	IP21	IP21	IP21	IP21	IP21	IP21

(1) The motors are standard supplied with star connection (Y), the customer can arrange a delta connection (Δ).

(2) The indicated current values are related to 400V voltage. For current values with delta connection, multiply the values by 1,732.

(3) The standard supply voltage is suitable for 380-400V/220-230V power supplies.

The geared machine is fan cooled with a fan mounted on the motor shaft or force ventilated with external fan 1 ~ 220 ... 240V 50/60Hz

		60Hz				
		AC2 1800/450 rpm 4/16 Poles				
		Asynchronous Rated Power [kW]				
		AC2 27	AC2 33	AC2 36	AC2 40	AC2 44
		Motor Parameters				
Rated Voltage (star connection) ^{(1) (3)}	[V]	400	400	400	400	400
Frequency	[Hz]	60	60	60	60	60
Synchronous Speed	[rpm]	1800/450	1800/450	1800/450	1800/450	1800/450
Asynchronous Speed	[rpm]	1675/365	1680/380	1670/360	1640/360	1655/375
Rated Current ⁽²⁾	[A]	63/40	71/52	76/59	82/55	88/62
Rated Torque	[Nm]	154	188	234	265	289
Cos φ Power Factor	[]	--	--	--	--	--
Starting Current	[A]	220	261	275	285	315
Starting Torque	[Nm]	358	430	502	570	600
Duty Cycle	[%]	30+10	30+10	30+10	30+10	30+10
Starts per Hour	[s/h]	180	180	180	180	180
Insulation Class	[]	F	F	F	F	F
Degree of Protection IP	[]	IP21	IP21	IP21	IP21	IP21

(1) The motors are standard supplied with star connection (Y), the customer can arrange a delta connection (Δ).

(2) The indicated current values are related to 400V voltage. For current values with delta connection, multiply the values by 1,732.

(3) The standard supply voltage is suitable for 380-400V/220-230V power supplies.

The geared machine is fan cooled with a fan mounted on the motor shaft or force ventilated with external fan 1 ~ 220 ... 240V 50/60Hz

		33Hz		
		VVVF 1000 rpm 4 Poles		
		Asynchronous Rated Power [kW]		
		VVVF 20	VVVF 25	VVVF 29
		Motor Parameters		
Rated Voltage (star connection) ^{(1) (3)}	[V]	400	400	400
Frequency	[Hz]	33	33	33
Synchronous Speed	[rpm]	990	990	990
Asynchronous Speed	[rpm]	954	943	948
Rated Current ⁽²⁾	[A]	43	51	60
Rated Torque	[Nm]	200	253	292
Cos ϕ Power Factor	[]	0,81	0,85	0,83
Starting Current	[A]	205	224	242
Starting Torque	[Nm]	500	630	690
Duty Cycle	[%]	60	60	60
Starts per Hour	[s/h]	240	240	240
Insulation Class	[]	F	F	F
Degree of Protection IP	[]	IP21	IP21	IP21

(1) The motors are standard supplied with star connection (Y), the customer can arrange a delta connection (Δ).

(2) The indicated current values are related to 400V voltage. For current values with delta connection, multiply the values by 1,732.

Motor are manufactured for 33HZ-50Hz. Inverter must assure those frequencies and voltages independently from the net frequency.

(3) The standard supply voltage is suitable for 380-400V/220-230V power supplies.

The geared machine is fan cooled with a fan mounted on the motor shaft or force ventilated with external fan 1 ~ 220 ... 240V 50/60Hz

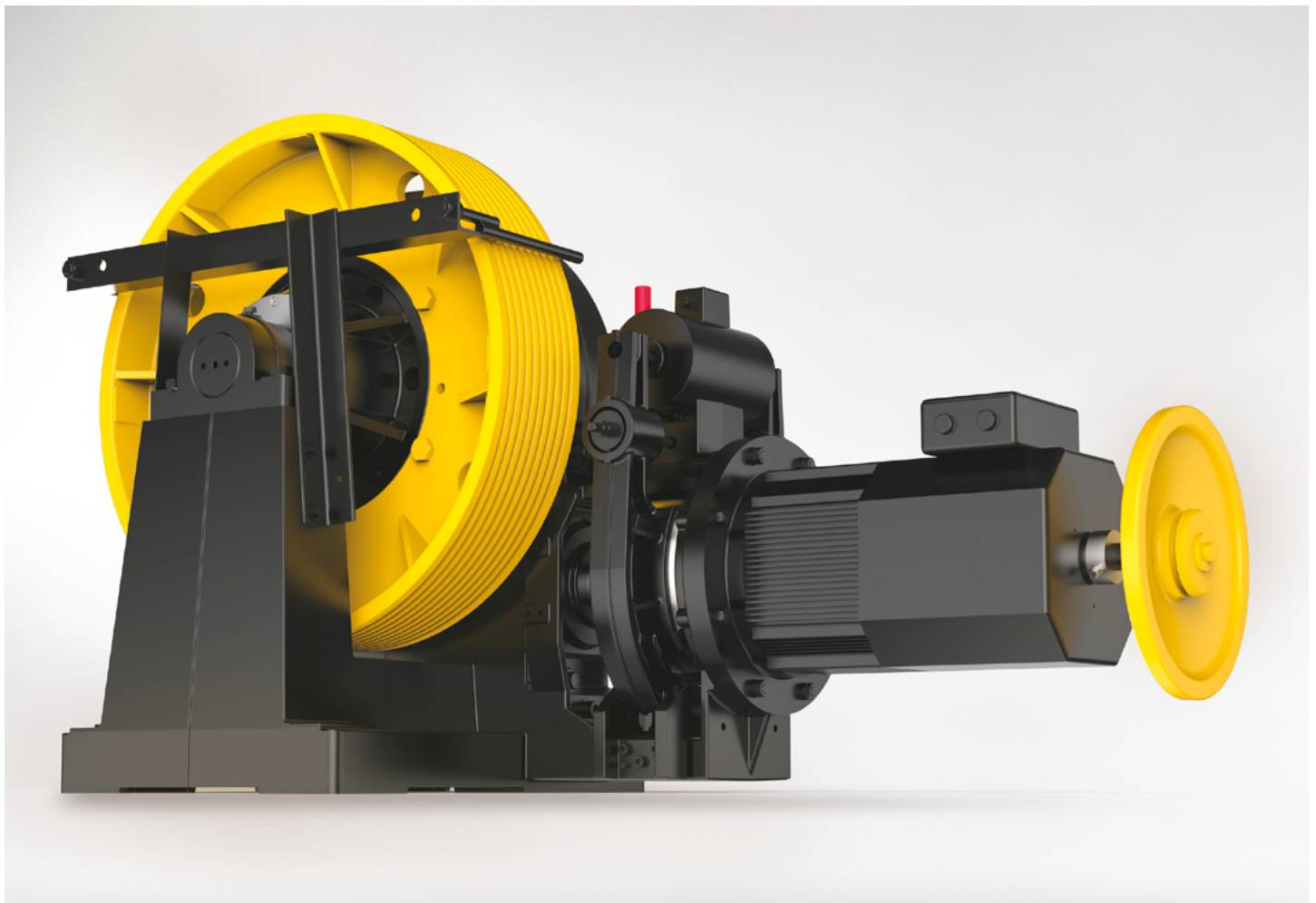

Wrapping System	Traction sheave		Max n° Grooves x D	Grooves Pitch
	D [mm]	E [mm]	n° x mm	l [mm]
CSW	690	208	10xD13	19
	690	208	9xD14	22
	690	208	9xD15	22
	690	208	9xD16	22
	770	252	12xD13	19
	770	252	11xD14	22
	770	252	11xD15	22
	770	252	11xD16	22
	800	208	10xD13	19
	800	208	9xD14	22
	800	208	9xD15	22
	800	208	9xD16	22
	885	208	10xD13	19
	885	208	9xD14	22
	885	208	9xD15	22
	885	208	9xD16	22

VCI

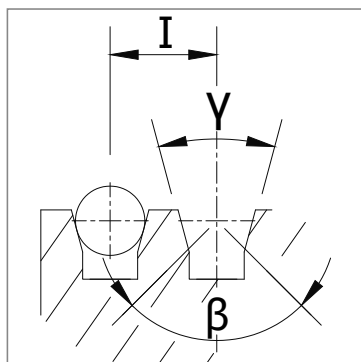

V grooves with undercut

UCI

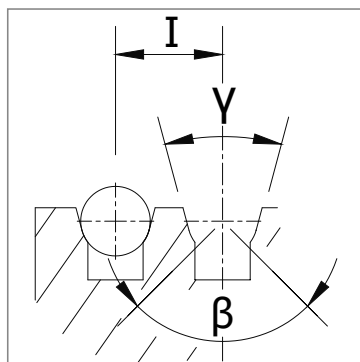

U grooves with undercut

γ = groove angle
 β = undercut angle
 I = grooves pitch

BEDPLATE | TOP MACHINE WITHOUT DIVERTING PULLEY FOR CSW WINDING

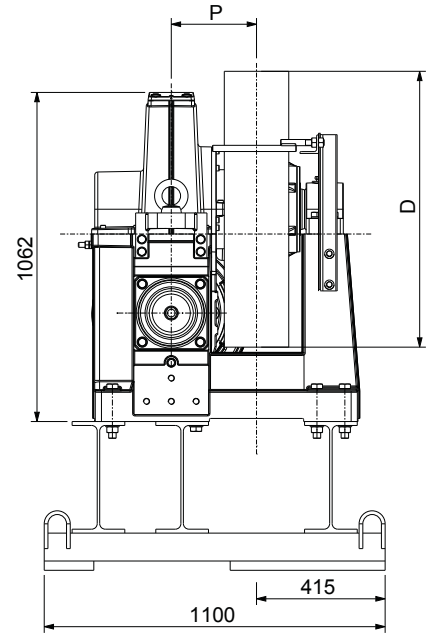
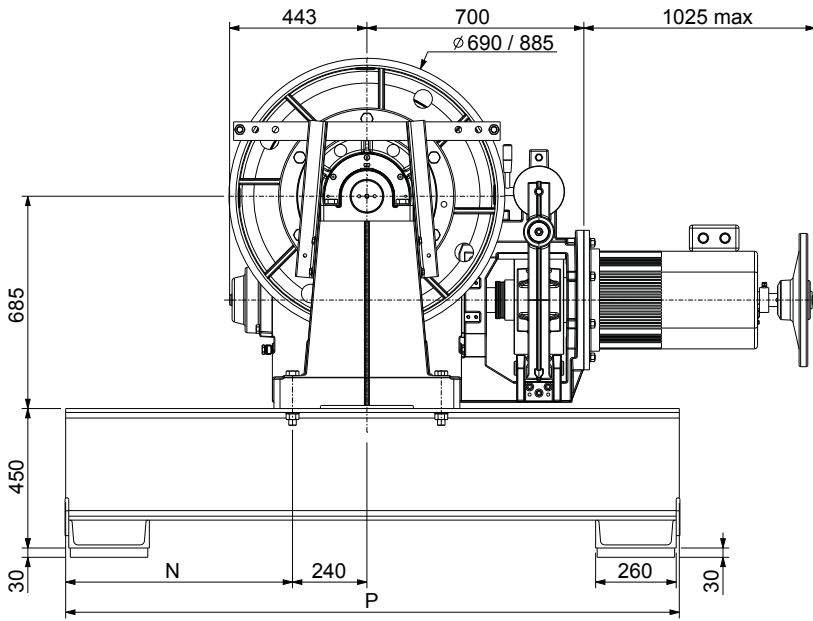

XTE7658

To ask for dimension (included vibration dampers)
 Dimensions P and N
 P standard = 1980 weight of machine bedplate 430 kg.
 P max = 3300 weight of machine bedplate 650 kg.
 P min = 1590 weight of machine bedplate 360 kg.

VIBRATIONS DAMPER SET UP

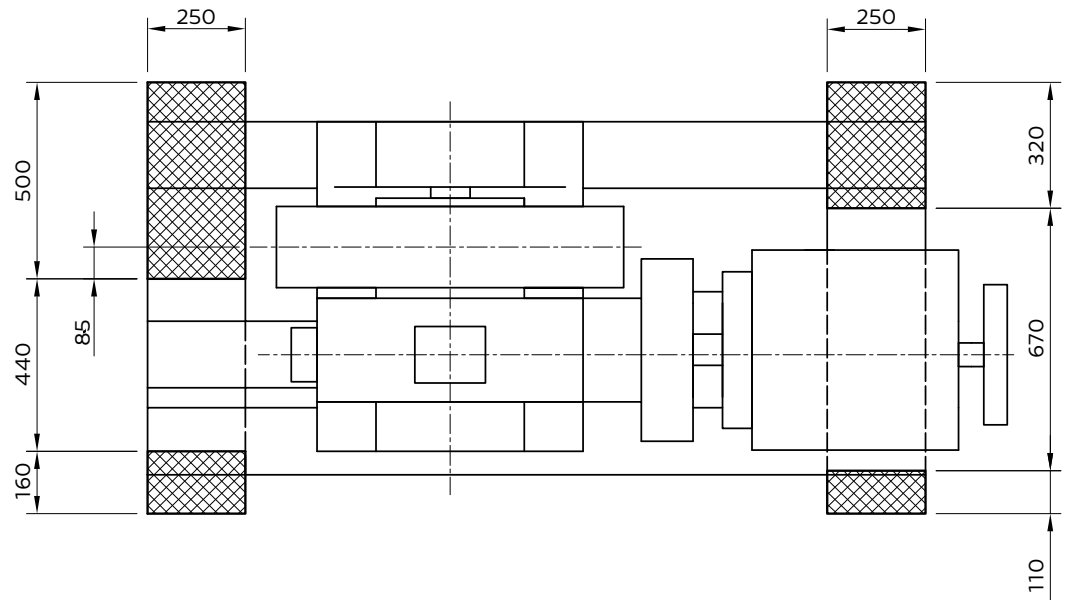

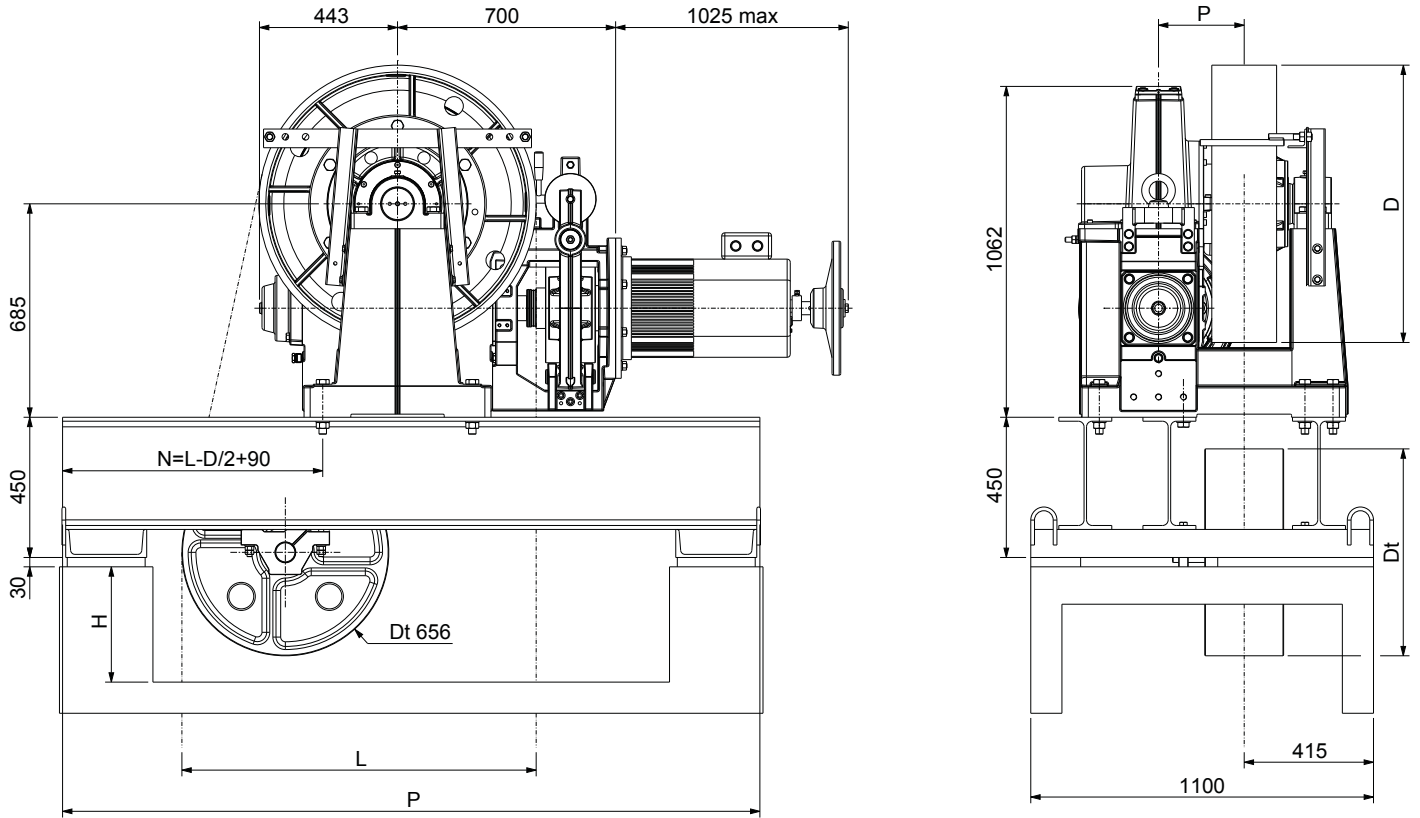

XTE7661

To ask for dimension (included vibration dampers)

Dimensions P and N

P standard = 1980 weight of machine bedplate 430 Kg

P max = 3300 weight of machine bedplate 650 Kg

P min = 1590 weight of machine bedplate 360 Kg

Dimension Hmin = (Dt / 2) + 75

Diverting pulley must not be located on the brake side. rope must go straight down.

VIBRATION DAMPER SET UP

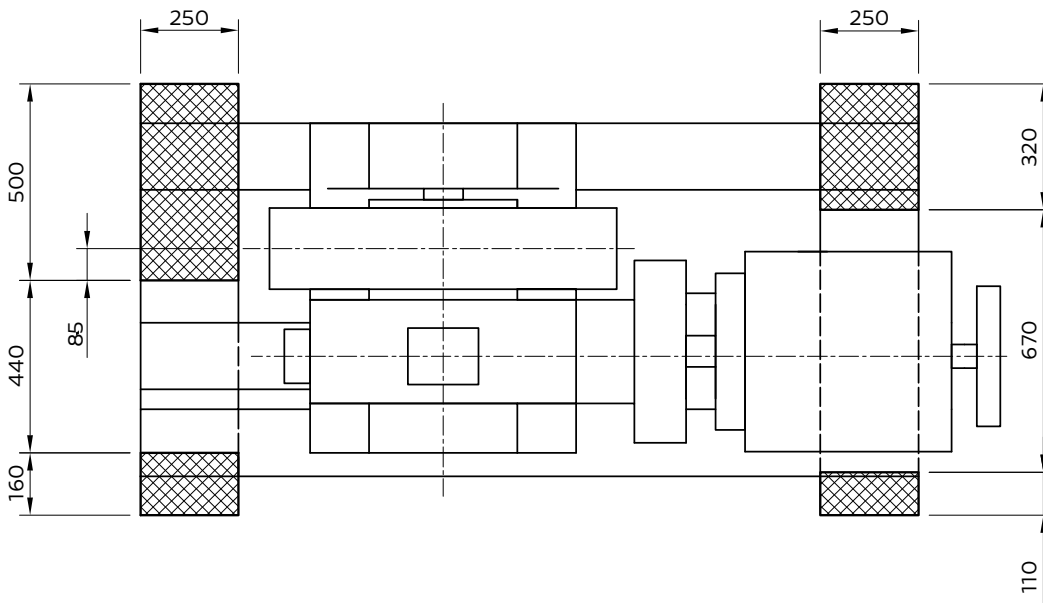

DIVERTING PULLEYS AND GROOVES NUMBER x ROPES DIAMETER

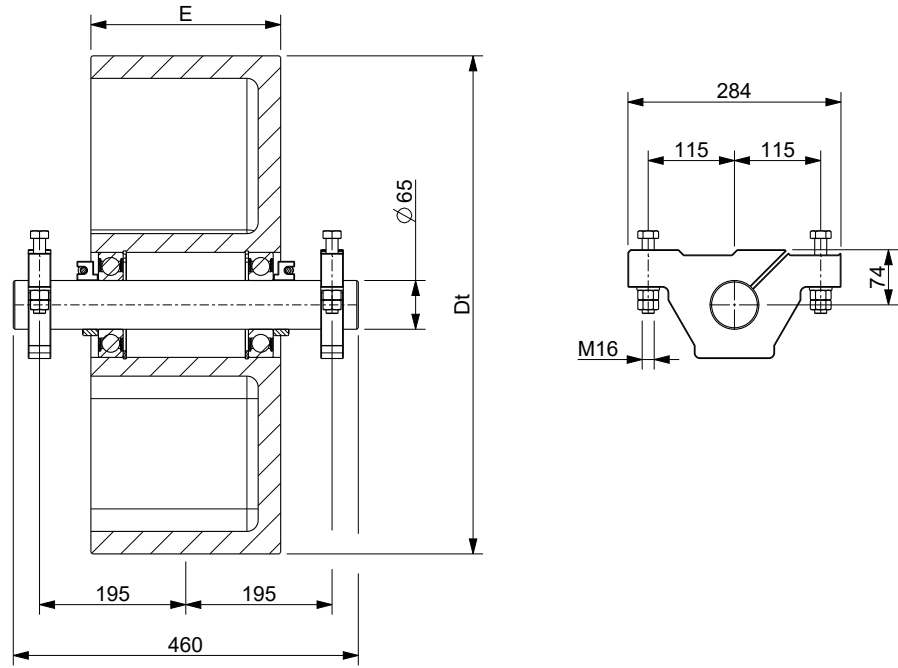

Diverting Pulley		Max n°Grooves x D	Grooves Pitch l [mm]	Distance X [mm]	Length L [mm]	Force F Max. [kN]
D [mm]	E [mm]					
656	253	12xD13	19	72	915	42,6
		11xD16	22	72	915	42,6



Versions

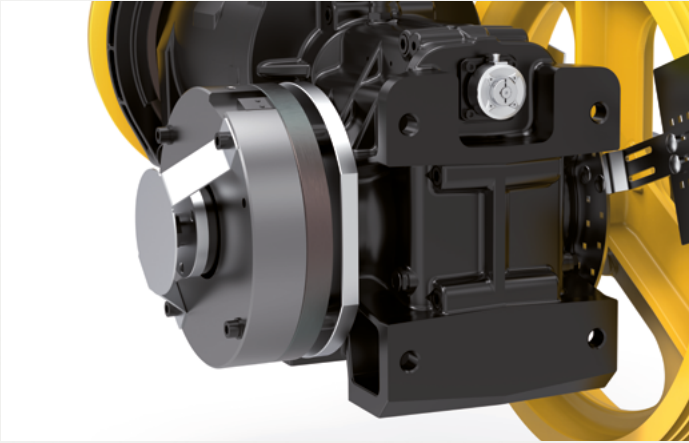

(B) SSB Brake

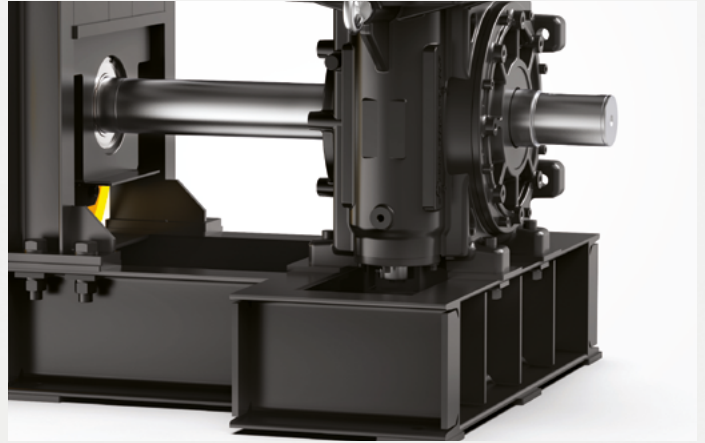

(LS) Extended shaft

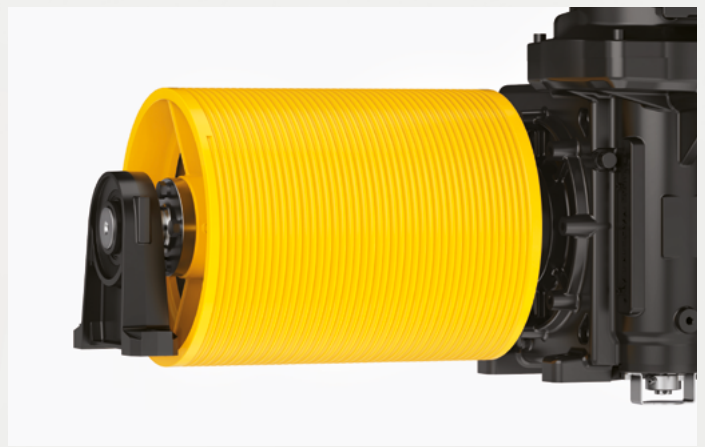

(T) Drum



Accessories



Protection for traction - diverting pulley

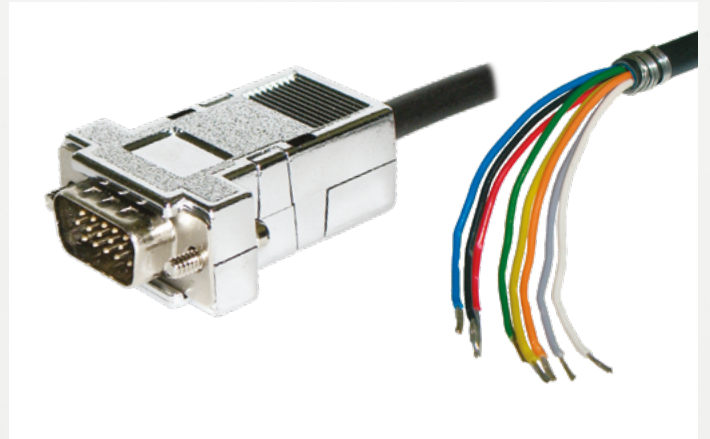

Encoder cable



Encoder



Bedplate





by
SICOR ITALY
AN  **ELEVANTIS COMPANY**

Sicor Italy S.R.L.

Viale Caproni, 32 Rovereto (TN) - Italy · Tel: +39 0464 484 111 · info@sicoritaly.com

www.sicoritaly.com