

MR21

GEARED MACHINES MR SERIES



Model	For rated loads up to	Speed range synchronous		Traction sheaves diameter	Max Static Load
		[kg]	50Hz [m/s]		
MR21 	2000	0,44 ... 3,76	0,53 ... 4,51	520,600,650,690,750	55 - 5600 72,6 - 7400 (TS)

Roping 1 : 1





Max. Static Load MR21	55 kN - 5600 kg
Max. Static Load MR21TS	72,6 kN - 7400 kg
Power Range 50 Hz 4 poles ACVVVF	9 ÷ 30 kW
Power Range 50 Hz 4/16 poles	9 ÷ 16,5 kW
Power Range 50 Hz 6 poles ACVVVF	7,5 ÷ 20 kW
Power Range 50 Hz 6/16 poles	7,5 ÷ 13,5 kW
Power Range 60 Hz 4 poles ACVVVF	10 ÷ 33 kW
Power Range 60 Hz 4/16 poles	10 ÷ 18 kW
Power Range 60 Hz 6 poles ACVVVF	8,2 ÷ 22 kW
Power Range 60 Hz 6/16 poles	8,2 ÷ 15 kW
Ratio	1/62; 1/51; 1/40; 2/63; 2/51; 3/47
Gear Weight	770 ÷ 1000 kg
Oil capacity	7,8 l
Gear Box Rh o Lh (from motor side)	Image ref. to Lh geared

The geared machine efficiency values are present above each "rated load" table
The motor efficiency values are present in the table "electric motor data"

DIMENSIONS MR21

Wrapping System	Traction sheave		Dimension	Load*)
	D [mm]	E [mm]	P [mm]	F [kN - kg]
ESW	520	176	303	50
	520	176		
CSW	600	160	290	55 - 5600
	650	160		
	690	160		
	750	160		

*) Max. static load on the slow shaft:
CSW: Conventional single wrap
ESW: Extended single wrap (patented)

Brake Electromagnet		
[V]	[A]	[W]
48	4,85	233
60	3,96	238
80	2,7	216
110	1,83	200
200	1,05	210

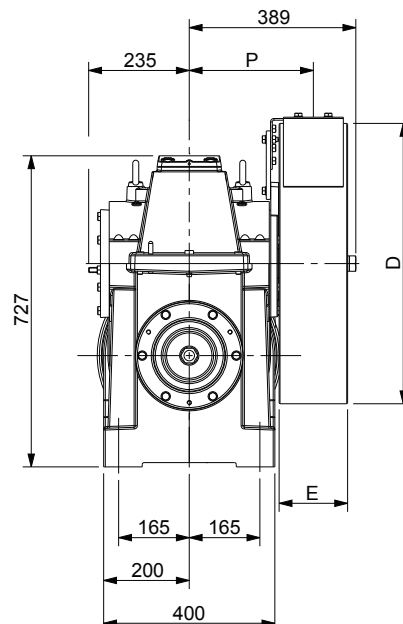
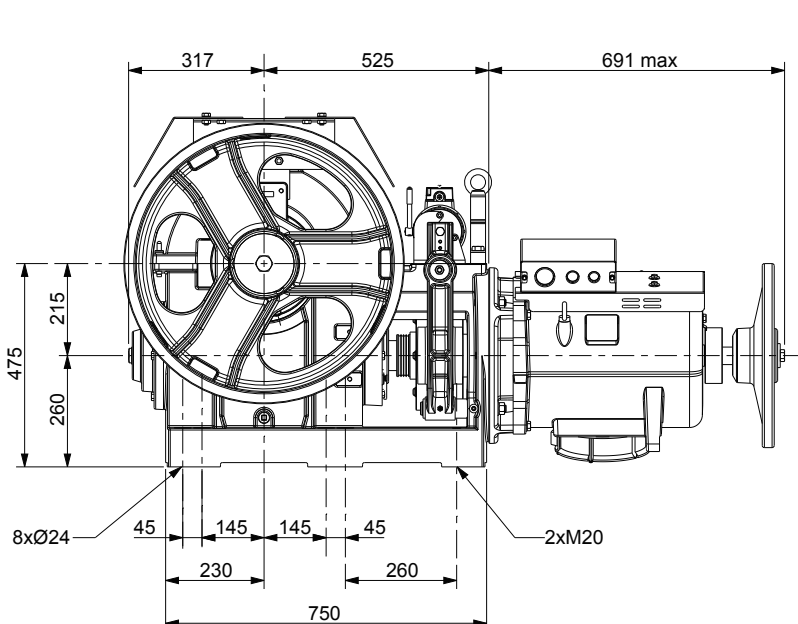

DIMENSIONS MR21TS

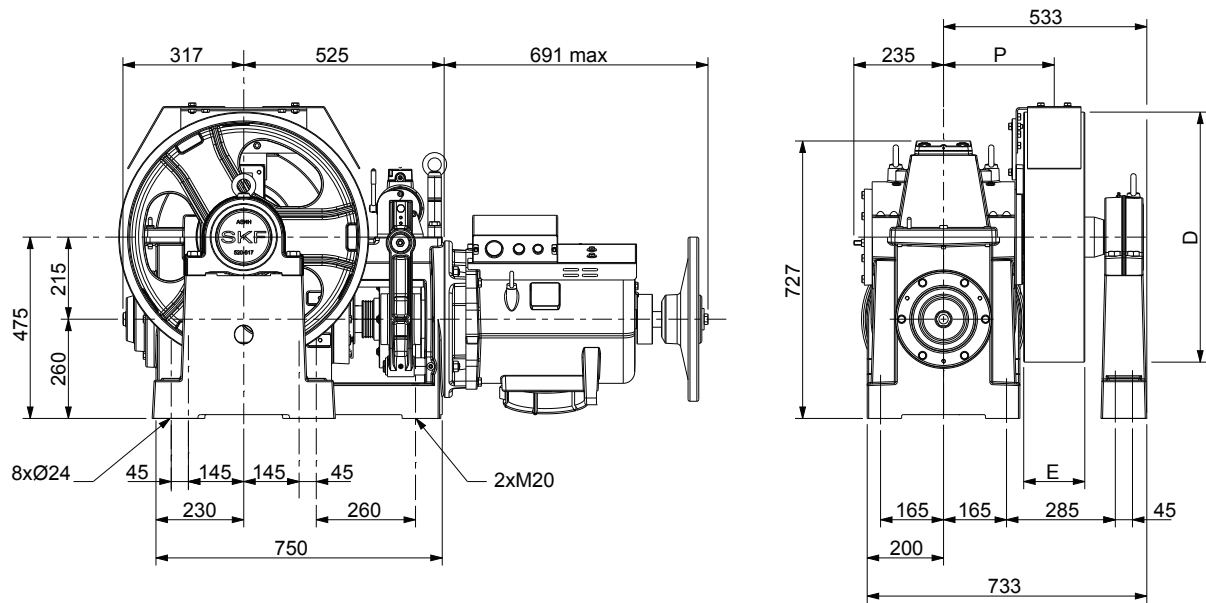

Wrapping System	Traction sheave		Dimension	Load*)
	D [mm]	E [mm]	P [mm]	F [kN - kg]
ESW	520	176	303	62,8 - 6400
	520	176		
CSW	600	160	290	72,6 - 7400
	650	160		
	690	160		
	750	160		

*) Max. static load on the slow shaft:
 CSW: Conventional single wrap
 ESW: Extended single wrap (patented)



				50Hz								60Hz									
				VVVF 1500 rpm 4 Poles AC2 1500/375 rpm 4/16 Poles								VVVF 1800 rpm 4 Poles AC2 1800/450 rpm 4/16 Poles									
				Motor Output [kW]																	
P _q		q _q		VVVF AC2 9	VVVF AC2 11	VVVF AC2 13,5	VVVF AC2 16,5	VVVF 20	VVVF 25	VVVF 30		VVVF AC2 10	VVVF AC2 12	VVVF AC2 15	VVVF AC2 18	VVVF 22	VVVF 27	VVVF 33			
Wrapping system		R.R.	Trac. Sheave Ø	Speed syn.	Max Rated Load								Speed syn.	Max Rated Load							
CSW	ESW	[i]	[mm]	[m/s]	[kg]	[kg]	[kg]	[kg]	[kg]	[kg]	[kg]	[m/s]	[kg]	[kg]	[kg]	[kg]	[kg]	[kg]	[kg]		
X	X	1/62	520	0,66	1440	1835	2045	--	--	--	--	0,79	1335	1635	--	--	--	--	--		
X	--	1/62	600	0,76	1245	1590	1770	--	--	--	--	0,91	1155	1415	--	--	--	--	--		
X	X	1/51	520	0,80	1205	1540	1960	2100	--	--	--	0,96	1115	1395	1765	--	--	--	--		
X	--	1/62	650	0,82	1150	1470	1635	--	--	--	--	0,99	1070	1305	--	--	--	--	--		
X	--	1/62	690	0,87	1085	1385	1540	--	--	--	--	1,05	1005	1230	--	--	--	--	--		
X	--	1/51	600	0,92	1040	1335	1700	1910	--	--	--	1,11	970	1210	1530	--	--	--	--		
X	--	1/62	750	0,95	995	1275	1415	--	--	--	--	1,14	925	1135	--	--	--	--	--		
X	--	1/51	650	1,00	960	1230	1565	1765	--	--	--	1,20	895	1115	1415	--	--	--	--		
X	X	1/40	520	1,02	945	1215	1550	1960	2100	--	--	1,23	885	1110	1450	1785	1890	--	--		
X	--	1/51	690	1,06	905	1160	1475	1660	--	--	--	1,28	840	1050	1330	--	--	--	--		
X	--	1/51	750	1,15	835	1065	1360	1530	--	--	--	1,39	775	970	1225	--	--	--	--		
X	--	1/40	600	1,18	815	1050	1345	1695	2100	--	--	1,41	765	960	1255	1550	1640	--	--		
X	--	1/40	650	1,28	755	970	1240	1565	1945	2000	--	1,53	705	890	1160	1430	1515	--	--		
X	X	2/63	520	1,30	800	1020	1295	1625	2010	2100	--	1,56	740	925	1200	1475	1690	--	--		
X	--	1/40	690	1,35	710	915	1170	1475	1830	1885	--	1,63	665	835	1090	1345	1425	--	--		
X	--	1/40	750	1,47	655	840	1075	1355	1685	1735	--	1,77	615	770	1005	1240	1310	--	--		
X	--	2/63	600	1,50	690	885	1120	1410	1745	1835	--	1,80	640	800	1040	1280	1465	--	--		
X	X	2/51	520	1,60	645	825	1050	1320	1635	2085	2100	1,92	600	750	975	1200	1500	1750	--		
X	--	2/63	650	1,62	640	815	1035	1300	1610	1695	--	1,94	595	740	960	1180	1350	--	--		
X	--	2/63	690	1,72	600	765	975	1225	1515	1595	--	2,06	560	695	905	1110	1275	--	--		
X	--	2/51	600	1,85	560	715	910	1145	1415	1805	1890	2,22	520	650	845	1040	1300	1515	--		
X	--	2/63	750	1,87	555	705	895	1125	1395	1470	--	2,24	515	640	830	1025	1170	--	--		
X	--	2/51	650	2,00	515	660	840	1055	1305	1665	1745	2,40	480	600	780	960	1200	1400	--		
X	--	2/51	690	2,13	485	620	790	995	1230	1570	1645	2,55	450	565	730	900	1130	1315	--		
X	--	2/51	750	2,31	445	570	725	915	1130	1445	1510	2,77	415	520	675	830	1040	1210	--		
X	X	3/47	520	2,61	400	515	655	825	1025	1305	1590	3,13	370	465	605	745	935	1170	1455		
X	--	3/47	600	3,01	345	445	570	715	885	1130	1375	3,61	320	400	525	645	810	1015	1260		
X	--	3/47	650	3,26	320	410	525	660	820	1045	1270	3,91	295	370	485	595	750	935	1165		
X	--	3/47	690	3,46	300	385	495	620	770	985	1195	4,15	280	350	455	560	705	880	1095		
X	--	3/47	750	3,76	275	355	455	570	710	905	1100	4,51	255	320	420	515	650	810	1010		

				50Hz								60Hz							
				Motor Output [kW]															
		R.R.		VVVF AC2 9	VVVF AC2 11	VVVF AC2 13,5	VVVF AC2 16,5	VVVF 20	VVVF 25	VVVF 30		VVVF AC2 10	VVVF AC2 12	VVVF AC2 15	VVVF AC2 18	VVVF 22	VVVF 27	VVVF 33	
		Max Output Torque	Geared Efficiency								Max Output Torque	Geared Efficiency							
		[Nm]									[Nm]								
1/62		3260	0,68	0,71	0,73	0,75	0,77	0,78	0,79		2610	0,68	0,71	0,73	0,75	0,77	0,78	0,79	
1/51		3520	0,69	0,72	0,75	0,77	0,79	0,80	0,81		2820	0,69	0,72	0,75	0,77	0,79	0,80	0,81	
1/40		3990	0,69	0,73	0,76	0,78	0,80	0,82	0,83		3020	0,70	0,73	0,76	0,78	0,80	0,82	0,83	
2/63		3380	0,74	0,78	0,80	0,82	0,84	0,86	0,87		2700	0,74	0,77	0,80	0,82	0,84	0,86	0,87	
2/51		3480	0,74	0,77	0,80	0,83	0,84	0,86	0,87		2790	0,74	0,77	0,80	0,83	0,84	0,86	0,87	
3/47		3560	0,75	0,79	0,82	0,84	0,86	0,88	0,89		3000	0,75	0,78	0,82	0,84	0,86	0,88	0,89	

Rated load values listed in the table include the weight of the ropes.
 To know the theoretical load, subtract the weight of the ropes.
 Position Of The Geared = Top Counterweight = 50% Plant efficiency = 0,80

50Hz							60Hz						
VVVF 1000 rpm 6 Poles AC2 1000/375 rpm 6/16 Poles							VVVF 1200 rpm 6 Poles AC2 1200/450 rpm 6/16 Poles						
Motor Output [kW]													
	VVVF AC2 7,5	VVVF AC2 9	VVVF AC2 11	VVVF AC2 13,5	VVVF 16,5	VVVF 20		VVVF AC2 8,2	VVVF AC2 10	VVVF AC2 12	VVVF AC2 15	VVVF AC2 18	VVVF AC2 22
Speed syn.	Max Rated Load						Speed syn.	Max Rated Load					
[m/s]	[kg]	[kg]	[kg]	[kg]	[kg]	[kg]	[m/s]	[kg]	[kg]	[kg]	[kg]	[kg]	[kg]
0,44	1900	2045	--	--	--	--	0,53	1695	2045	--	--	--	--
0,51	1645	1770	--	--	--	--	0,61	1470	1770	--	--	--	--
0,53	1595	1970	2100	--	--	--	0,64	1420	1800	2100	--	--	--
0,55	1520	1635	--	--	--	--	0,66	1355	1635	--	--	--	--
0,58	1430	1540	--	--	--	--	0,70	1280	1540	--	--	--	--
0,62	1380	1710	1910	--	--	--	0,74	1230	1560	1910	--	--	--
0,63	1315	1415	--	--	--	--	0,76	1175	1415	--	--	--	--
0,67	1275	1575	1765	--	--	--	0,80	1135	1440	1765	--	--	--
0,68	1255	1560	1965	2100	--	--	0,82	1115	1420	1760	2100	--	--
0,71	1200	1485	1660	--	--	--	0,85	1070	1355	1660	--	--	--
0,77	1105	1365	1530	--	--	--	0,92	985	1245	1530	--	--	--
0,79	1090	1350	1705	2100	--	--	0,94	965	1230	1525	1965	2100	--
0,85	1005	1245	1570	1975	2035	--	1,02	890	1135	1405	1810	2035	--
0,86	1055	1305	1635	2045	2100	--	1,04	940	1190	1465	1880	2100	--
0,90	945	1175	1480	1860	1915	--	1,08	840	1070	1325	1705	1915	--
0,98	870	1080	1360	1715	1765	--	1,18	775	985	1220	1570	1765	--
1,00	915	1130	1415	1775	1835	--	1,20	815	1030	1270	1625	1835	--
1,07	855	1055	1325	1665	2070	2100	1,28	760	965	1190	1525	1865	2100
1,08	845	1040	1305	1635	1695	--	1,30	755	950	1170	1500	1695	--
1,15	795	980	1230	1540	1595	--	1,38	710	895	1105	1415	1595	--
1,23	740	915	1150	1440	1790	1890	1,48	660	835	1030	1320	1615	1890
1,25	730	905	1130	1420	1470	--	1,50	650	825	1015	1300	1470	--
1,33	680	845	1060	1330	1655	1745	1,60	610	770	950	1220	1490	1745
1,42	645	795	1000	1255	1560	1645	1,70	570	725	895	1150	1405	1645
1,54	590	730	920	1150	1435	1510	1,85	525	665	825	1055	1290	1510
1,74	530	660	830	1040	1295	1595	2,09	475	600	745	955	1165	1450
2,01	460	570	720	905	1125	1380	2,41	410	520	645	825	1010	1255
2,17	425	525	665	835	1035	1275	2,61	380	480	595	765	935	1160
2,31	400	495	625	785	975	1200	2,77	355	450	560	720	880	1090
2,51	370	455	575	720	900	1105	3,01	330	415	515	660	810	1005

50Hz							60Hz						
Motor Output [kW]													
	VVVF AC2 7,5	VVVF AC2 9	VVVF AC2 11	VVVF AC2 13,5	VVVF 16,5	VVVF 20		VVVF AC2 8,2	VVVF AC2 10	VVVF AC2 12	VVVF AC2 15	VVVF AC2 18	VVVF AC2 22
Max Output Torque	Geared Efficiency						Max Output Torque	Geared Efficiency					
[Nm]							[Nm]						
3260	0,72	0,74	0,76	0,77	0,79	0,80	3260	0,70	0,73	0,75	0,77	0,78	0,79
3520	0,73	0,75	0,77	0,79	0,80	0,82	3520	0,72	0,74	0,76	0,78	0,80	0,81
4060	0,73	0,76	0,78	0,80	0,82	0,83	4060	0,72	0,75	0,77	0,79	0,81	0,82
3380	0,78	0,81	0,83	0,84	0,86	0,87	3380	0,77	0,80	0,82	0,84	0,85	0,86
3480	0,78	0,81	0,83	0,85	0,86	0,87	3480	0,77	0,80	0,82	0,84	0,85	0,87
3560	0,80	0,82	0,85	0,87	0,88	0,89	3560	0,78	0,81	0,83	0,86	0,87	0,89

50Hz											
VVVF 1500 rpm 4 Poles AC2 1500/375 rpm 4/16 Poles											
Asynchronous Rated Power [kW]											
	VVVF 9	VVVF 11	VVVF 13,5	VVVF 16,5	VVVF 20	VVVF 25	VVVF 30	AC2 9	AC2 11	AC2 13,5	AC2 16,5
Motor Parameters											
Rated Voltage (star connection) ^{(1) (3)} [V]	400	400	400	400	400	400	400	400	400	400	400
Frequency [Hz]	50	50	50	50	50	50	50	50	50	50	50
Synchronous Speed [rpm]	1500	1500	1500	1500	1500	1500	1500	1500/375	1500/375	1500/375	1500/375
Asynchronous Speed [rpm]	1460	1457	1476	1477	1480	1481	1478	1402/306	1370/300	1375/302	1368/298
Rated Current ⁽²⁾ [A]	21,2	24,1	27,4	34,1	37	45,8	61,7	20/16,7	29/17	33/19	39/22
Rated Torque [Nm]	63	72	87	107	129	161	194	61	76	94	115
Cos ϕ Power Factor []	0,7	0,76	0,84	0,84	0,84	0,84	0,79	0,8	0,75	0,78	0,78
Starting Current [A]	133	157	123	162	225	305	441	65	125	145	158
Starting Torque [Nm]	145	163	160	190	253	357	380	147	183	208	236
Duty Cycle [%]	60	60	60	60	60	60	60	30+10	30+10	30+10	30+10
Starts per Hour [s/h]	240	240	240	240	240	240	240	180	180	180	180
Insulation Class []	F	F	F	F	F	F	F	F	F	F	F
Degree of Protection IP []	IP21	IP21	IP21	IP21	IP21	IP21	IP21	IP21	IP21	IP21	IP21

(1) The motors are standard supplied with star connection (Y), the customer can arrange a delta connection (Δ).

(2) The indicated current values are related to 400V voltage. For current values with delta connection, multiply the values by 1,732.

Motor are manufactured for 50Hz. Inverter must assure those frequencies and voltages independently from the net frequency.

(3) The standard supply voltage is suitable for 380-400V/220-230V power supplies.

The geared machine includes a fan, 1~220...240V, 50/60Hz.

60Hz											
VVVF 1800 rpm 4 Poles AC2 1800/450 rpm 4/16 Poles											
Asynchronous Rated Power [kW]											
	VVVF 10	VVVF 12	VVVF 15	VVVF 18	VVVF 22	VVVF 27	VVVF 33	AC2 10	AC2 12	AC2 15	AC2 18
Motor Parameters											
Rated Voltage (star connection) ^{(1) (3)} [V]	400	400	400	400	400	400	400	400	400	400	400
Frequency [Hz]	60	60	60	60	60	60	60	60	60	60	60
Synchronous Speed [rpm]	1800	1800	1800	1800	1800	1800	1800	1800/450	1800/450	1800/450	1800/450
Asynchronous Speed [rpm]	1710	1748	1774	1778	1779	1782	1781	1664/373	1645/360	1650/358	1648/361
Rated Current ⁽²⁾ [A]	21,5	25,5	27	35	44	55	65	22/18,4	31/18	40/24	49/26
Rated Torque [Nm]	56	65	81	97	118	145	177	57	68	87	104
Cos ϕ Power Factor []	0,76	0,76	0,84	0,84	0,85	0,84	0,86	0,8	0,75	0,76	0,76
Starting Current [A]	131	150	128	160	229	301	432	105	120	103	128
Starting Torque [Nm]	125	163	160	176	230	335	400	147	159	199	239
Duty Cycle [%]	60	60	60	60	60	60	60	30+10	30+10	30+10	30+10
Starts per Hour [s/h]	240	240	240	240	240	240	240	180	180	180	180
Insulation Class []	F	F	F	F	F	F	F	F	F	F	F
Degree of Protection IP []	IP21	IP21	IP21	IP21	IP21	IP21	IP21	IP21	IP21	IP21	IP21

(1) The motors are standard supplied with star connection (Y), the customer can arrange a delta connection (Δ).

(2) The indicated current values are related to 400V voltage. For current values with delta connection, multiply the values by 1,732.

Motor are manufactured for 60Hz. Inverter must assure those frequencies and voltages independently from the net frequency.

(3) The standard supply voltage is suitable for 380-400V/220-230V power supplies.

The geared machine is fan cooled with a fan mounted on the motor shaft or force ventilated with external fan 1 ~ 220 ... 240V 50/60Hz

50Hz

VVVF 1000 rpm 6 Poles
AC2 1000/375 rpm 6/16 Poles

Asynchronous Rated Power [kW]

VVVF 7,5	VVVF 9	VVVF 11	VVVF 13,5	VVVF 16,5	VVVF 20	AC2 7,5	AC2 9	AC2 11	AC2 13,5
Motor Parameters									
400	400	400	400	400	400	400	400	400	400
50	50	50	50	50	50	50	50	50	50
1000	1000	1000	1000	1000	1000	1000/375	1000/375	1000/375	1000/375
963	980	980	981	982	981	910/300	912/298	914/296	920/299
20	21	26	33	39	47	24/20	29/24	31/29	34/31
74	87	107	131	160	194	76	94	113	139
0,66	0,7	0,72	0,7	0,7	0,71	0,66	0,67	0,68	0,67
69	96	123	163	201	245	56	58	107	145
125	107	144	200	242	314	125	134	274	350
60	60	60	60	60	60	30+10	30+10	30+10	30+10
240	240	240	240	240	240	180	180	180	180
F	F	F	F	F	F	F	F	F	F
IP21	IP21	IP21	IP21	IP21	IP21	IP21	IP21	IP21	IP21

60Hz

VVVF 1200 rpm 6 Poles
AC2 1200/450 rpm 6/16 Poles

Asynchronous Rated Power [kW]

VVVF 8,2	VVVF 10	VVVF 12	VVVF 15	VVVF 18	VVVF 22	AC2 8,2	AC2 10	AC2 12	AC2 15
Motor Parameters									
400	400	400	400	400	400	400	400	400	400
60	60	60	60	60	60	60	60	60	60
1200	1200	1200	1200	1200	1200	1200/450	1200/450	1200/450	1200/450
1152	1175	1173	1176	1174	1174	1095/363	1092/365	1091/359	1093/361
21	22	25,8	33	38	46	27/22	35/26	36/31	43/37
68	81	98	122	146	179	68	87	105	131
0,67	0,72	0,71	0,72	0,72	0,73	0,66	0,65	0,67	0,66
76	79	106	119	144	193	62	64	134	165
112	121	146	175	202	228	113	121	247	310
60	60	60	60	60	60	30+10	30+10	30+10	30+10
240	240	240	240	240	240	180	180	180	180
F	F	F	F	F	F	F	F	F	F
IP21	IP21	IP21	IP21	IP21	IP21	IP21	IP21	IP21	IP21

(1) The motors are standard supplied with star connection (Y), the customer can arrange a delta connection (Δ).

(2) The indicated current values are related to 400V voltage. For current values with delta connection, multiply the values by 1,732.

(3) The standard supply voltage is suitable for 380-400V/220-230V power supplies.

The geared machine is fan cooled with a fan mounted on the motor shaft or force ventilated with external fan 1 ~ 220 ... 240V 50/60Hz

Wrapping System	Traction sheave		Max n° Grooves x D	Grooves Pitch	
	D [mm]	E [mm]	n° x mm	l [mm]	
ESW	520	176	7xD10	24	
	520	176	6xD13	30	
	520	176	10xD10	16	
	520	176	9xD11	18	
	520	176	9xD12	18	
	520	176	8xD13	19	
	600	160	9xD10	16	
	600	160	8xD11	18	
	600	160	8xD12	18	
	600	160	8xD13	19	
	600	160	6xD14	22	
	600	160	6xD15	22	
	650	160	9xD10	16	
	650	160	8xD11	18	
	650	160	8xD12	18	
	650	160	8xD13	19	
	650	160	6xD14	22	
	650	160	6xD15	22	
	CSW	650	160	6xD16	22
		690	160	9xD10	16
690		160	8xD11	18	
690		160	8xD12	18	
690		160	8xD13	19	
690		160	6xD14	22	
690		160	6xD15	22	
690		160	6xD16	22	
750		160	9xD10	16	
750		160	8xD11	18	
750		160	8xD12	18	
750		160	8xD13	19	
750		160	6xD14	22	
750		160	6xD15	22	
750		160	6xD16	22	

VCI

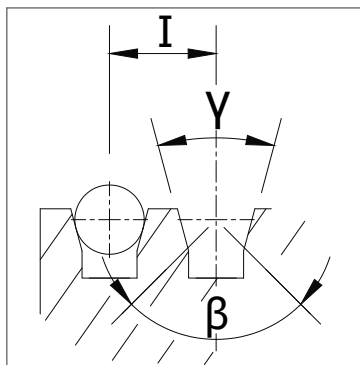

V grooves with undercut

UCI

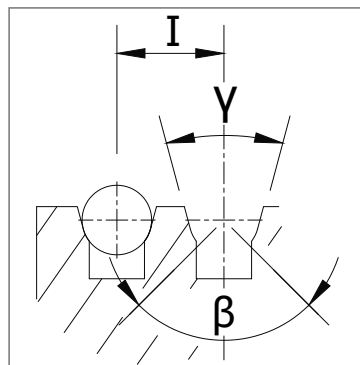

U grooves with undercut

γ = groove angle
 β = undercut angle
 I = grooves pitch

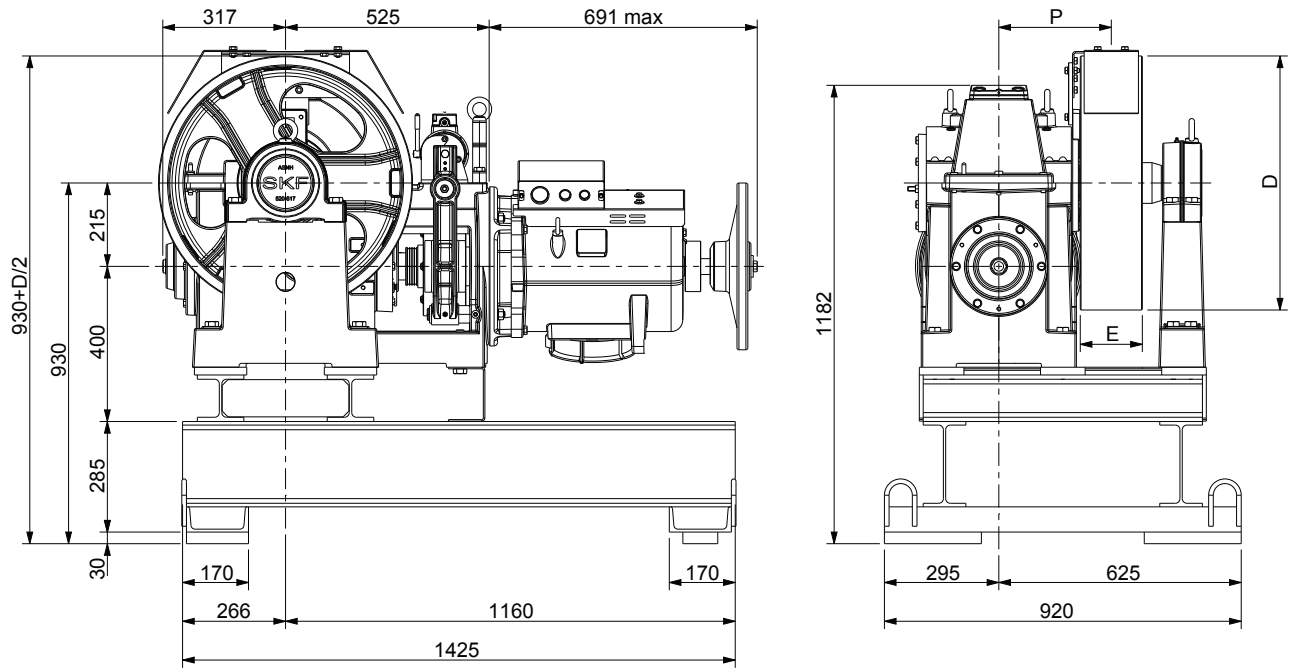
BEDPLATE | TOP MACHINE WITHOUT DIVERTING PULLEY FOR CSW WINDING (SHORT)

MR21 **XTE0025** Weight of machine bedplate: 175 kg.

MR21TS **XTE2953** Weight of machine bedplate: 224 kg

Note: Machine room floor thickness min. 250 mm. The bed plate includes vibration dampers

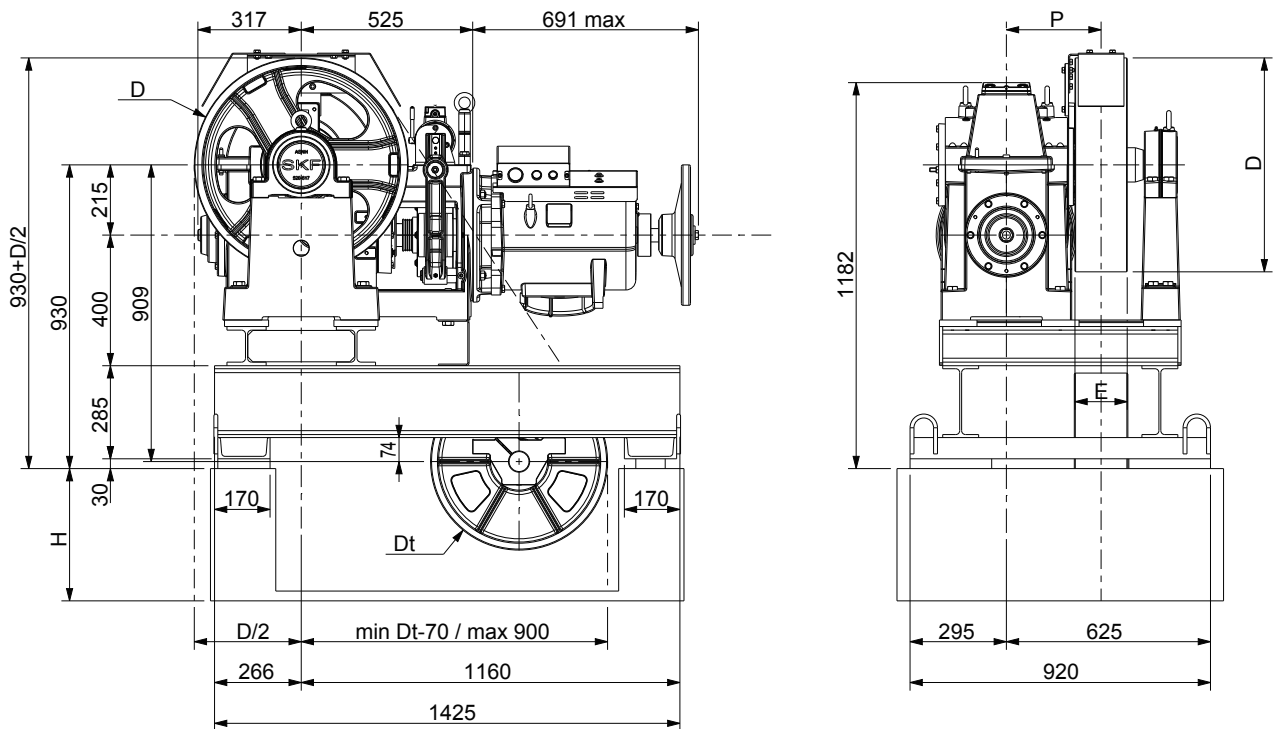
BEDPLATE | TOP MACHINE WITH DIVERTING PULLEY FOR CSW WINDING (SHORT)

MR21 **XTE0029** Weight of machine bedplate: 175 kg.

MR21TS **XTE2955** Weight of machine bedplate: 253 kg

Note: Machine room floor thickness min. 250 mm. The bed plate includes vibration dampers (without diverting pulley)

Dt = 534 mm

Dimension Hmin = (Dt/2) + 75

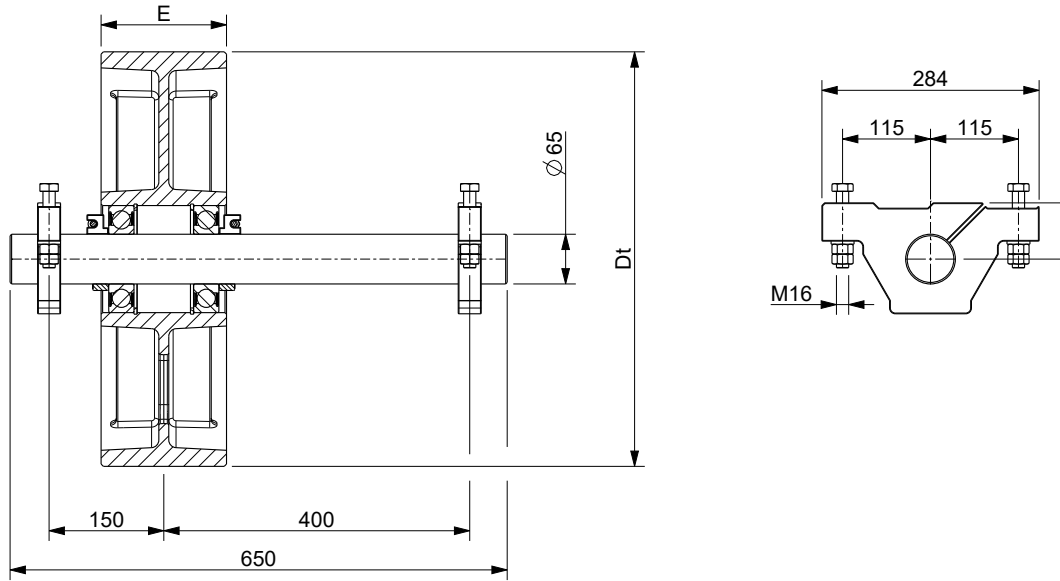

Diverting Pulley		Max n°Grooves x D	Grooves Pitch	Distance	Length	Force
Dt [mm]	Et [mm]	n° x mm	l [mm]	X [mm]	L [mm]	F Max [kN]
534	124	7xD10	16	72+90	725	23
		6xD12	18	72+90	725	23
		6xD13	19	72+90	725	23
	164	10xD10	16	72+90	725	24,2
		8xD12	18	72+90	725	24,2
		8xD13	19	72+90	725	24,2
656	186	11xD10	16	122	725	24,9
		10xD12	18	122	725	24,9
		9xD13	19	122	725	24,9
		8xD16	22	122	725	24,9

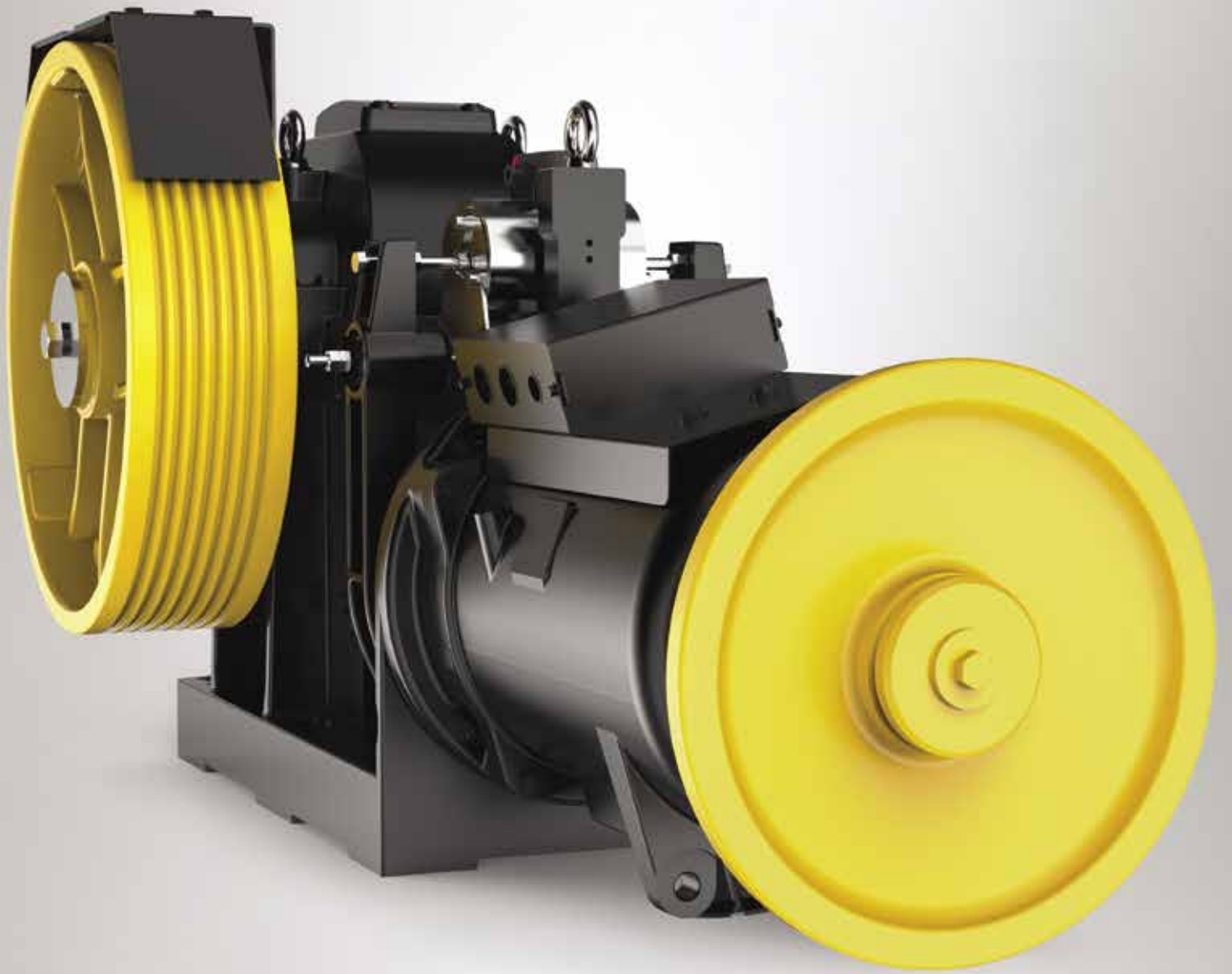



by
SICOR ITALY
AN  ELEVANTIS COMPANY

Sicor Italy S.R.L.

Viale Caproni, 32 Rovereto (TN) - Italy · Tel: +39 0464 484 111 · info@sicoritaly.com

www.sicoritaly.com