

Model	For rated loads up to	Car speed range in 2:1	Traction sheaves diameter range	Max Static Load
	[kg]	[m/s]	[mm]	[kN-kg]
SG22 	1600	0,63 ... 2,00	120(*) , 160(*), 200, 210, 240, 270, 320	27,5-2800

With sheave on drive side.

* Pu-coated ropes

Highlighted pulley diameter is the one used to calculate max allowed capacity in standard condition (see calculation for each model).

Sample data; for more detailed evaluations we recommend our product configurator.



SG22 - SG22F

Rated Torque **290 Nm SG22F (S3 40%)**
 Braking Torque **2x280 Nm**
 Power Range (min - max) **1,6 - 8,8 kW**
 Maximum Static Load **27,5 kN - 2800 kg**
 Maximum Weight **163 kg**
 Motor Rated Voltage **360 V - 208 V**

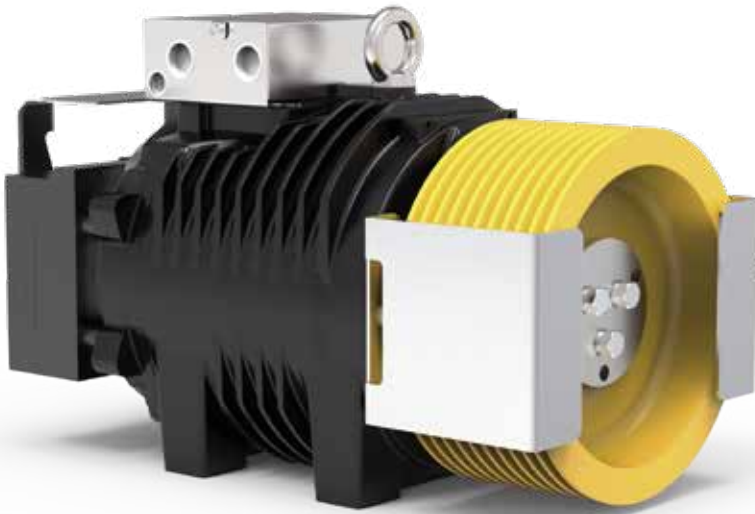

SG22 Gearless without fan kit

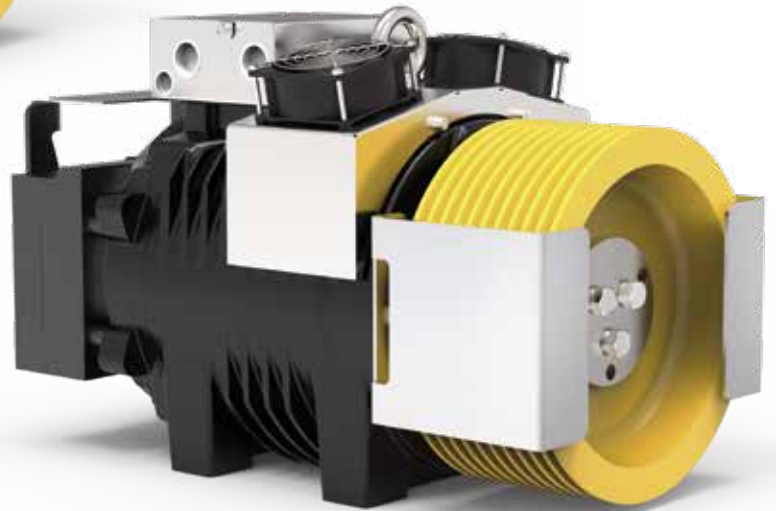

SG22F Gearless with fan kit

CONFIGURATION EXAMPLES TABLE**

Model	Ø Traction sheave	Car speed	Q Rated load	P Car weight	rpm	P ***	I ***	Installation frequency	Ropes Nr x diameter Ø
	[mm]	[m/s]	[kg]	[kg]	[min ⁻¹]	[kW]	[A]	[Hz]	[mm]
SG22145B	120	0,63	1600	1600	199	6,25	15,39	33,4	7 x Ø 6,5 (*)
SG22145B	160	0,63	1000	1200	199	3,90	12,9	25	5 x Ø 6,5 (*)
SG22145B	160	1,00	1000	1200	254	6,22	15,1	39,6	5 x Ø 6,5 (*)
SG22145BF	200	0,63	800	950	120	3,61	9,7	20	9 x Ø 6,5
SG22145BF	200	1,00	800	950	199	5,85	15,3	31,7	10 x Ø 6,5
SG22145B	210	0,63	800	950	120	3,55	9,91	19	8 x Ø 6,5
SG22145BF	210	1,00	675	930	199	5,01	13,7	30,2	9 x Ø 6,5
SG22145BF	210	1,60	630	930	291	7,83	18,7	48,5	10 x Ø 6,5
SG22145BF	240	0,63	675	930	120	2,99	9,6	16,6	7 x Ø 6,5
SG22145BF	240	1,00	675	930	199	4,88	15,3	26,4	8 x Ø 6,5
SG22145B	240	1,60	480	700	254	5,83	13,4	42,4	7 x Ø 6,5
SG22145BF	320	0,63	480	700	120	2,17	9,3	12,5	4 x Ø 8
SG22145BF	320	1,00	480	700	120	3,60	9,7	19,8	5 x Ø 8
SG22145BF	320	1,60	400	680	199	5,27	13,64	31,8	4 x Ø 8
SG22145BF	320	2,00	400	600	254	6,29	15,4	39,7	5 x Ø 8

Configurations specifications	
Harmonized standards of reference	EN 81-20 e EN 81-50
Roping - Wrapping type	2:1 - Conventional Single Wrap
Machine position	Top
Compartment efficiency	0,9
Nr of deflecti on pulleys on ball bearing	2 for rated load ≤ 1000 kg - 3 for rated load > 1000 kg
Counterweight balancing	50%
Travel height	30 m
Duty cycle	S3 40%
Starts/hour	180
Wrapping angle	180°
Acceleration	0,3±0,5m/s ² for car speed ≤ 1 m/s - 0,5±0,7m/s ² for car speed > 1 m/s

Refer to the product configurator for the value of the short circuit torque, the relative speed and the minimum voltage that allows the operation of gearless machine.

* Pu-coated ropes

** Sample data; for more detailed evaluations we recommend our product configurator.

*** Values referred to configuration table (360V)

SG22 - DIMENSIONS

Mod. SG22145B

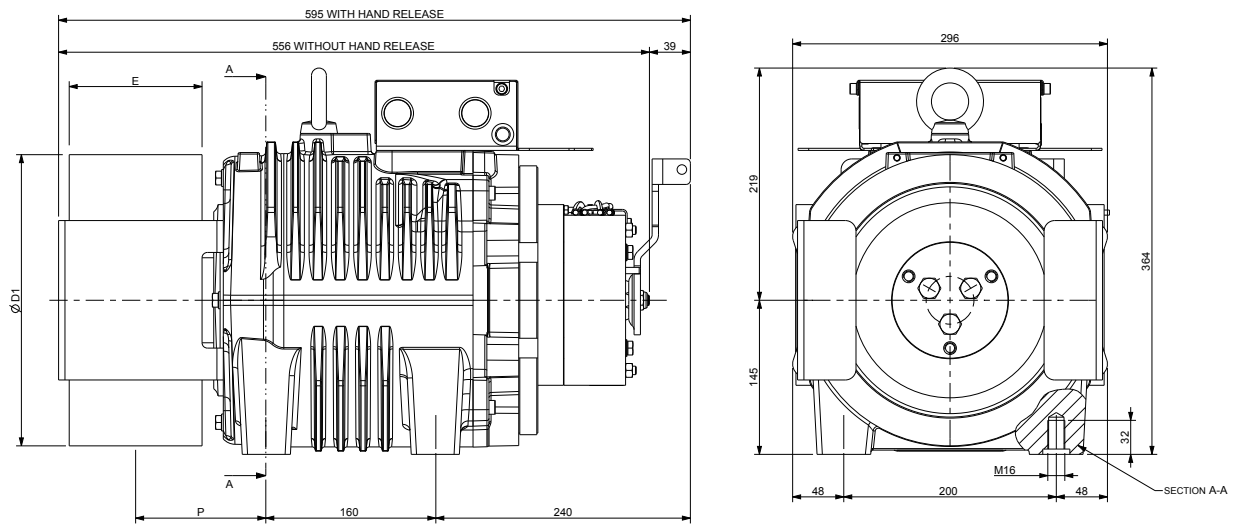

Ø D1	E	P	Max Weight	Inertia	Roping System	Torque S3 40%	Max Static Load	Max Power **
[mm]	[mm]	[mm]	[kg]	[kgm ²]		[Nm]	[kN - kg]	[kW]
120	125	122	160	0,11	CSW*	250	27,5 - 2800	7,6
160				0,15				
200				0,20				
210				0,23				
240				0,29				
270				0,54				
320	117		0,63					

Brake Specifications

Braking Torque: 2x280 [Nm]
Standard Supply Voltage: 207 [V DC]
Power: 2x79 [W]
Degree of Protection: IP10

Standard Encoder Data

Type: Absolute EnDat
Model: Heidenhain ECN 1313
Positions values/rev: 2048 imp 13 bits
Degree of Protection: IP40
Standard Cable Length: 10 [m]

* CSW: Conventional single wrap.

** Sample data; for more detailed evaluations we recommend our product configurator.

SG22F - DIMENSIONS

Mod. SG22145BF

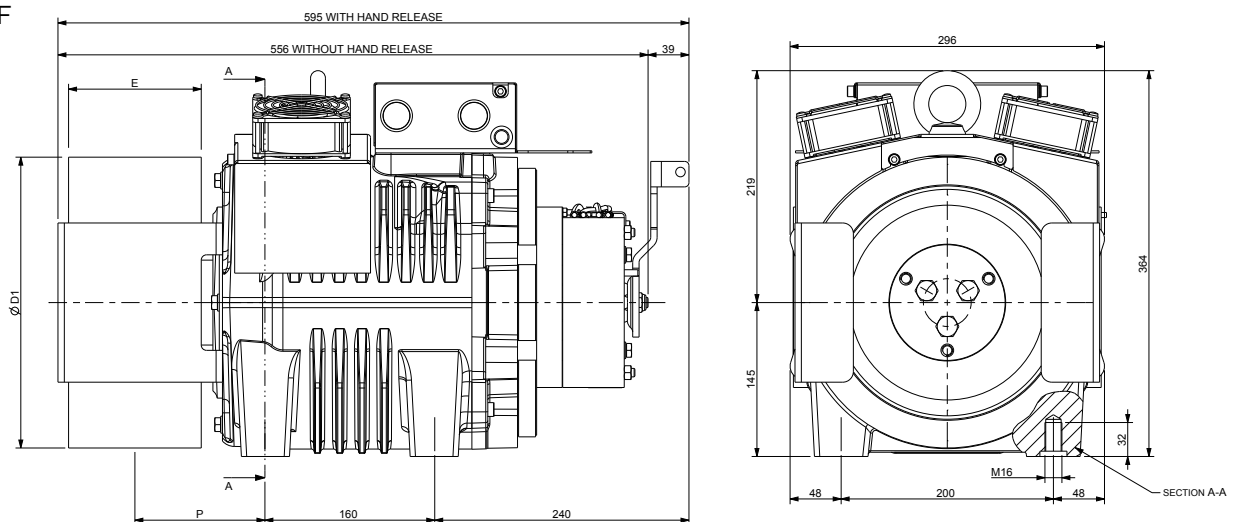

Ø D1	E	P	Max Weight	Inertia	Roping System	Torque S3 40%	Max Static Load	Max Power **
[mm]	[mm]	[mm]	[kg]	[kgm ²]		[Nm]	[kN - kg]	[kW]
120	125	122	163	0,11	CSW*	290	27,5 - 2800	8,8
160				0,15				
200				0,20				
210				0,23				
240				0,29				
270				0,54				
320	117		0,63					

Brake Specifications

Braking Torque: 2x280 [Nm]
Standard Supply Voltage: 207 [V DC]
Power: 2x79 [W]
Degree of Protection: IP10

Standard Encoder Data

Type: Absolute EnDat
Model: Heidenhain ECN 1313
Positions values/rev: 2048 imp 13 bits
Degree of Protection: IP40
Standard Cable Length: 10 [m]

Ventilation data

Voltage: 220 [V]
Power: 2x16 [W]

* CSW: Conventional single wrap.

** Sample data; for more detailed evaluations we recommend our product configurator.



by
SICOR ITALY
AN  ELEVANTIS COMPANY

Sicor Italy S.R.L.

Viale Caproni, 32 Rovereto (TN) - Italy · Tel: +39 0464 484 111 · info@sicoritaly.com

www.sicoritaly.com