

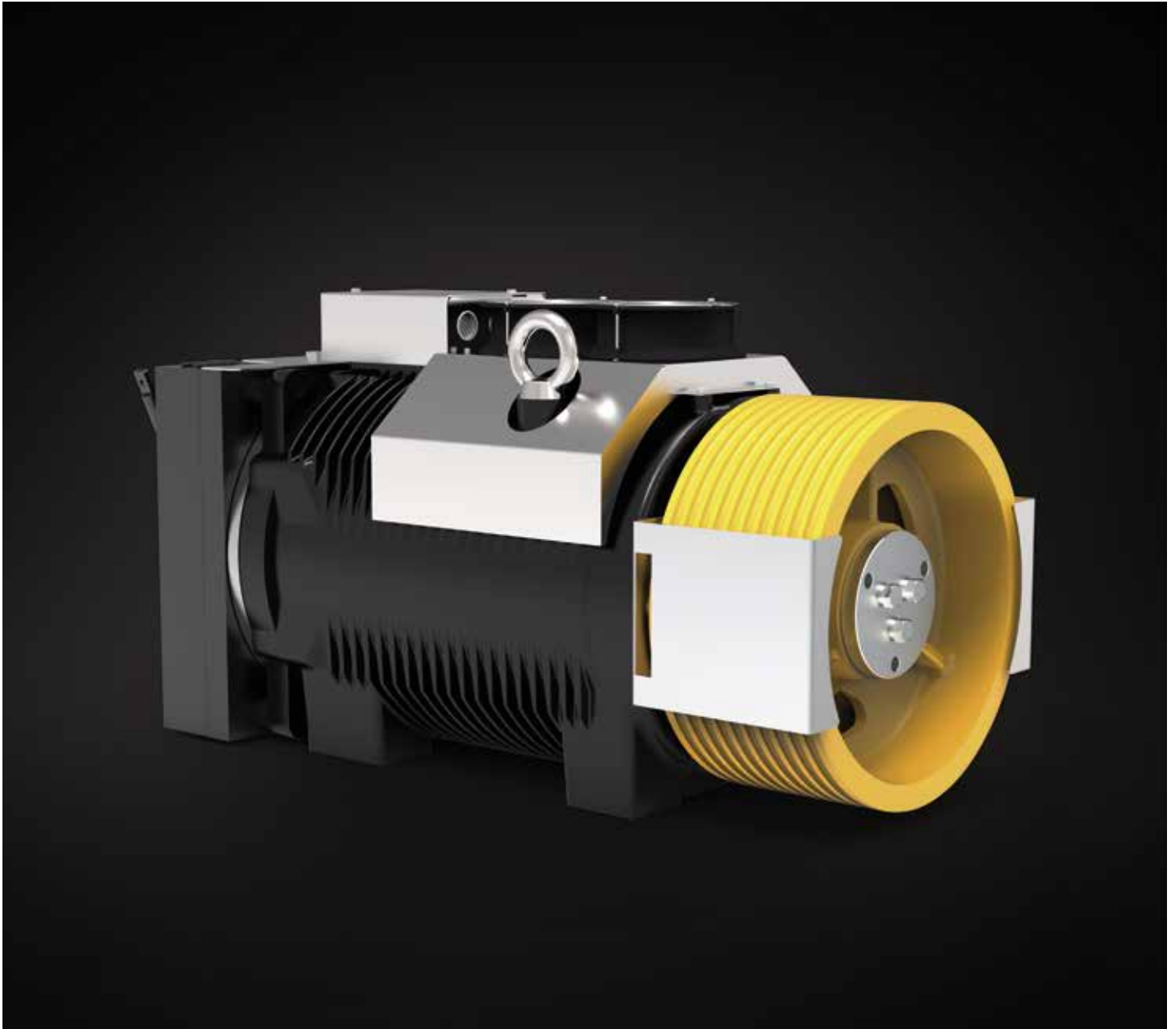

SG70

GEARLESS MACHINES

SG SERIES



Model	For rated loads up to [kg]	Car speed range in 2:1 [m/s]	Traction sheaves diameter range [mm]	Max Static Load [kN-kg]
SG70 	3000	0,63 ... 2,50	320, 360, 400, 440 , 480, 520, 600	58,9-6000

With sheave on drive side.

* Pu-coated ropes

Highlighted pulley diameter is the one used to calculate max allowed capacity in standard condition (see calculation for each model).

Sample data; for more detailed evaluations we recommend our product configurator.



SG70 - SG70F

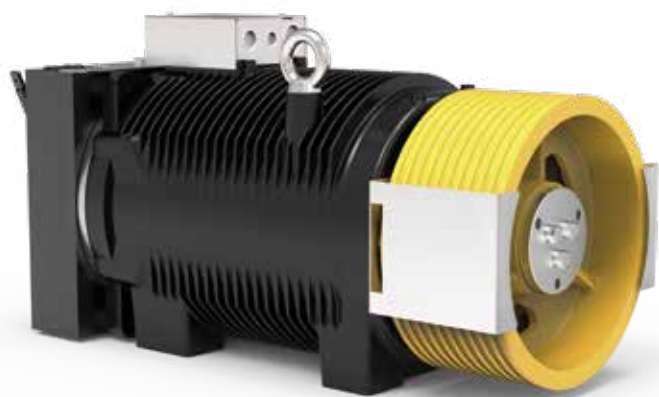

SG70 Gearless without fan kit

Rated Torque **1960 Nm SG70F (S3 40%)**
 Braking Torque **2x2200 Nm**
 Power Range (min - max) **8,2 - 49,3 kW**
 Maximum Static Load **58,9 kN - 6000 kg**
 Maximum Weight **713 kg**
 Motor Rated Voltage **360 V**

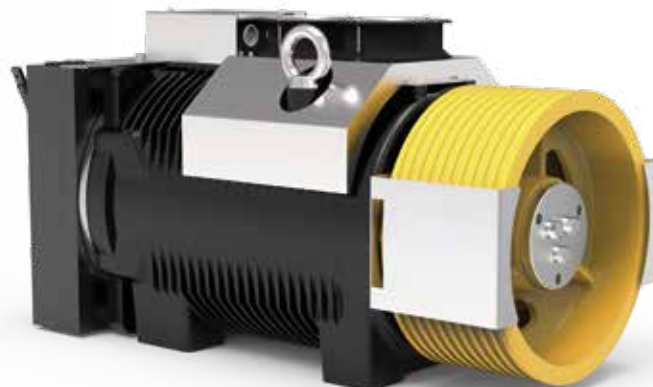

SG70F Gearless with fan kit

CONFIGURATION EXAMPLES TABLE**

Model	Ø Traction sheave	Car speed	Q Rated load	P Car weight	rpm	p ***	I ***	Installation frequency	Ropes Nr x diameter Ø
	[mm]	[m/s]	[kg]	[kg]	[min ⁻¹]	[kW]	[A]	[Hz]	[mm]
SG70220A	320	0,63	2500	2000	96	10,53	34,8	18,7	14 x Ø 8
SG70220A	320	1,00	2500	2000	144	16,84	48,2	29,9	14 x Ø 8
SG70220A	320	1,60	2000	1650	192	22,24	52,0	47,6	14 x Ø 8
SG70220A	320	2,00	2000	1650	240	27,84	64,7	59,7	14 x Ø 8
SG70220AF	360	0,63	3000	2500	96	12,33	45,9	16,6	14 x Ø 8
SG70220AF	360	1,00	3000	3500	144	16,69	63,6	26,5	14 x Ø 8
SG70220A	360	1,60	2500	2000	192	26,87	70,7	42,4	14 x Ø 8
SG70220A	360	2,00	2000	1650	240	27,47	71,9	53	13 x Ø 8
SG70220AF	400	0,63	3000	2500	96	12,53	57,7	15	10 x Ø 10
SG70220AF	400	1,00	2500	2000	96	17,00	44,2	23,8	10 x Ø 10
SG70220A	400	1,60	2000	1650	192	22,18	64,9	38,1	9 x Ø 10
SG70220A	400	2,00	2000	1650	192	28,34	66,1	47,8	10 x Ø 10
SG70220A	400	2,50	1600	1600	240	29,65	68,8	59,8	10 x Ø 10
SG70220AF	440	0,63	3000	2500	96	12,50	56,8	13,6	10 x Ø 10
SG70220AF	440	1,00	2500	2000	96	16,70	47,8	21,7	9 x Ø 10
SG70220A	440	1,60	2000	1650	144	22,22	54,8	34,7	9 x Ø 10
SG70220AF	440	2,00	2000	1650	192	28,37	72,7	43,5	10 x Ø 10
SG70220AF	440	2,50	2000	1650	240	33,57	85,8	54,3	8 x Ø 11
SG70220AF	480	0,63	2500	2000	96	10,47	51,8	12,5	7 x Ø 11
SG70220AF	480	1,00	2500	2000	96	16,98	52,8	19,9	8 x Ø 11
SG70220AF	480	1,60	2000	1650	144	22,21	59,8	31,8	9 x Ø 10
SG70220AF	480	2,00	2000	1650	192	27,80	77,9	39,8	9 x Ø 10
SG70220AF	480	2,50	1600	1600	240	29,45	82,1	49,8	8 x Ø 11
SG70220AF	520	0,63	2500	2000	48	27,40	31,5	11,5	7 x Ø 10
SG70220AF	520	1,00	2000	1950	96	13,41	45,3	18,3	6 x Ø 11
SG70220AF	520	1,60	2000	1650	144	21,35	62,3	29,3	7 x Ø 10
SG70220AF	520	2,00	2000	1650	192	28,22	85,5	36,8	8 x Ø 11
SG70220AF	520	2,50	1600	1600	192	28,36	68,8	46	8 x Ø 10
SG70220AF	600	0,63	2000	1650	48	8,08	25,0	10	5 x Ø 10
SG70220AF	600	1,00	2000	1650	96	13,13	51,1	15,9	5 x Ø 11
SG70220AF	600	1,60	1600	1600	144	17,28	58,2	25,4	5 x Ø 11
SG70220AF	600	2,00	1600	1600	144	21,59	58,1	31,8	6 x Ø 10
SG70220AF	600	2,50	1600	1600	192	27,03	75,8	39,8	6 x Ø 10

Configurations specifications	
Harmonized standards of reference	EN 81-20 e EN 81-50
Roping - Wrapping type	2:1 - Conventional Single Wrap
Machine position	Top
Compartment efficiency	0,9
Nr of deflecti on pulleys on ball bearing	2 for rated load ≤ 1000 kg - 3 for rated load > 1000 kg
Counterweight balancing	50%
Travel height	30 m
Duty cycle	S3 40%
Starts/hour	180
Wrapping angle	180°
Acceleration	0,3±0,5m/s ² for car speed ≤ 1 m/s - 0,5±0,7m/s ² for car speed > 1 m/s

Refer to the product configurator for the value of the short circuit torque, the relative speed and the minimum voltage that allows the operation of gearless machine.

* Pu-coated ropes

** Sample data; for more detailed evaluations we recommend our product configurator.

*** Values referred to configuration table (360V)

SG70 - DIMENSIONS

Mod. SG70220A

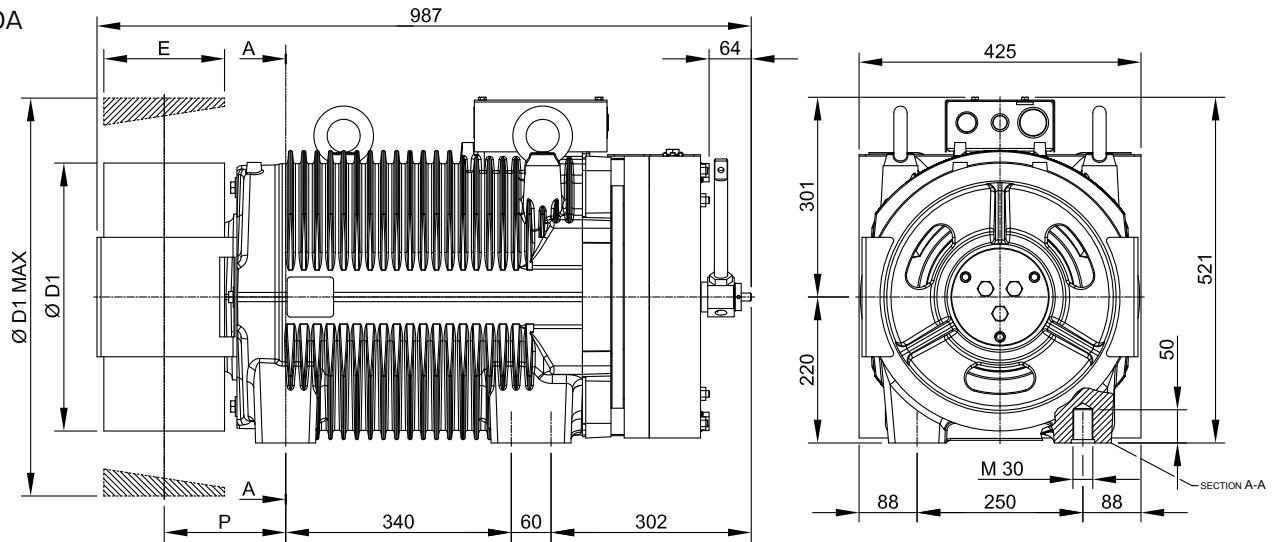

Ø D1	E	P	Max Weight	Inertia	Roping System	Torque S3 40%	Max Static Load	Max Power **
[mm]	[mm]	[mm]	[kg]	[kgm ²]		[Nm]	[kN - kg]	[kW]
320	182	183	652	2,11	CWS*	1635	58,9 - 6000	41,1
360				2,51				
400				3,06				
440				3,71				
480				4,11				
520	150	167		4,86				
600				7,21				

Brake Specifications

Braking Torque: 2x2200 [Nm]
Standard Supply Voltage: 207 [V DC]
Power: 2x178 [W]
Degree of Protection: IP10

Standard Encoder Data

Type: Absolute EnDat
Model: Heidenhain ECN 1313
Positions values/rev: 2048 imp 13 bits
Degree of Protection: IP40
Standard Cable Length: 10 [m]

* CSW: Conventional single wrap.

** Sample data; for more detailed evaluations we recommend our product configurator.

SG70F - DIMENSIONS

Mod. SG70220AF

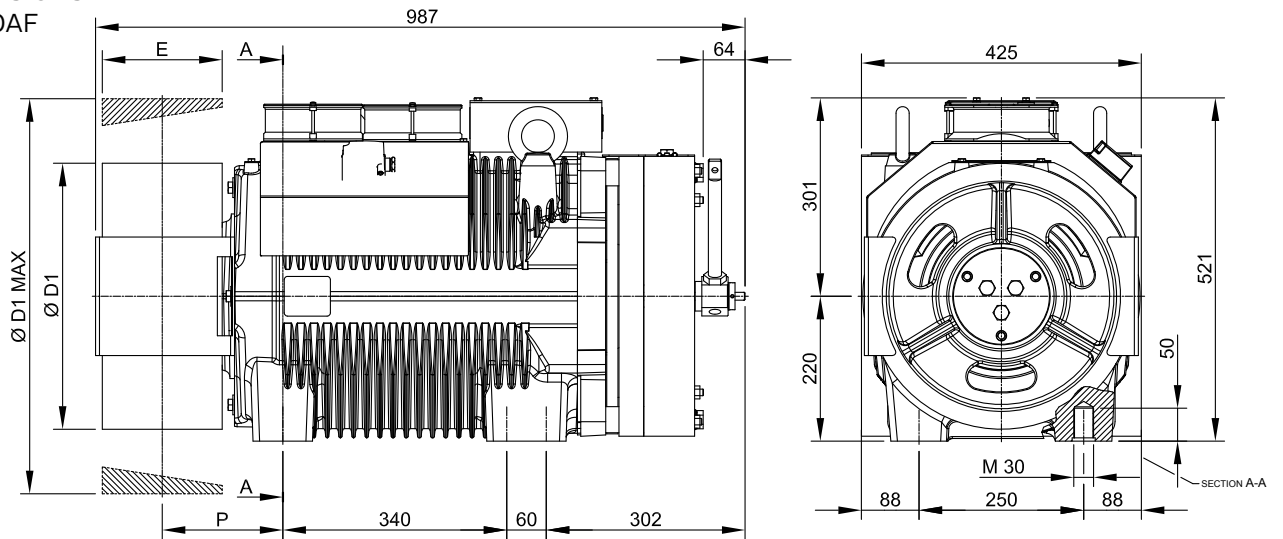

Ø D1	E	P	Max Weight	Inertia	Roping System	Torque S3 40%	Max Static Load	Max Power **
[mm]	[mm]	[mm]	[kg]	[kgm ²]		[Nm]	[kN - kg]	[kW]
320	182	183	713	2,11	CWS*	1960	58,9 - 6000	49,3
360				2,51				
400				3,06				
440				3,71				
480				4,11				
520	150	167		4,86				
600				7,21				

Brake Specifications

Braking Torque: 2x2200 [Nm]
Standard Supply Voltage: 207 [V DC]
Power: 2x178 [W]
Degree of Protection: IP10

Standard Encoder Data

Type: Absolute EnDat
Model: Heidenhain ECN 1313
Positions values/rev: 2048 imp 13 bits
Degree of Protection: IP40
Standard Cable Length: 10 [m]

Ventilation data

Voltage: 220 [V]
Power: 2x38 [W]

* CSW: Conventional single wrap.

** Sample data; for more detailed evaluations we recommend our product configurator.



by
SICOR ITALY
AN  ELEVANTIS COMPANY

Sicor Italy S.R.L.

Viale Caproni, 32 Rovereto (TN) - Italy · Tel: +39 0464 484 111 · info@sicoritaly.com

www.sicoritaly.com