



# SH140

## GEARED MACHINES SH SERIES



Model	For rated loads up to [kg]	Speed range synchronous		Traction sheaves diameter [mm]	Max Static Load [kN-kg]
		50Hz [m/s]	60Hz [m/s]		
SH140 	875	0,25 ... 3,01	0,31 ... 3,61	360,400,450,480, 520,560,600	32,4 - 3300
SH140LS 	875	0,25 ... 3,01	0,31 ... 3,61	360,400,450,480, 520,560,600	19,6 - 2000

Roping 1 : 1





Max. Static Load	<b>32,4 kN - 3300 kg</b>
Power Range 50 Hz 4 poles VVVF	<b>4 ÷ 11 kW</b>
Power Range 50 Hz 4/16 poles	<b>4 ÷ 9 kW</b>
Power Range 50 Hz 6 poles VVVF	<b>2,7 ÷ 5 kW</b>
Power Range 50 Hz 6/16 poles	<b>2,7 ÷ 4,5 kW</b>
Power Range 60 Hz 4 poles VVVF	<b>4,4 ÷ 12 kW</b>
Power Range 60 Hz 4/16 poles	<b>4,4 ÷ 10 kW</b>
Power Range 60 Hz 6 poles VVVF	<b>4 ÷ 5,5 kW</b>
Power Range 60 Hz 6/16 poles	<b>4 ÷ 4,9 kW</b>
Ratio	<b>1/71; 1/59; 1/52; 1/45; 1/37; 2/71; 2/53; 3/47</b>
Geared Weight	<b>280 kg</b>
Oil capacity	<b>3,6 l</b>
Geared machine Rh o Lh (from motor side)	<b>Image ref. to Lh geared</b>

The geared machine efficiency values are present above each "rated load" table  
The motor efficiency values are present in the table "electric motor data"

## DIMENSIONS

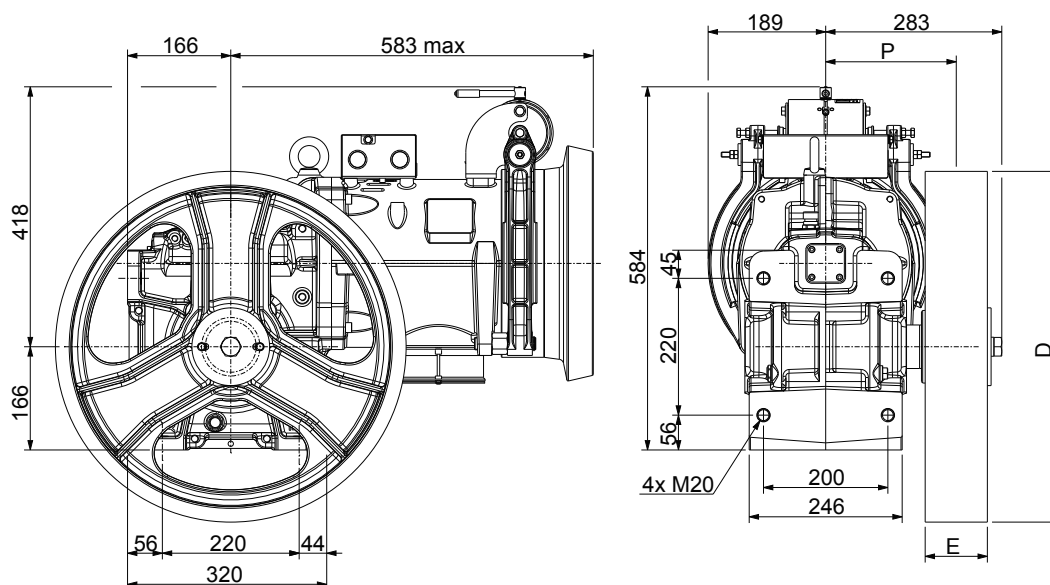

Wrapping System	Traction sheave		Dimension	Load*)	Static Load Direction
	D [mm]	E [mm]			
CSW	360	100	210	32,4 - 3300	<div style="text-align: center;">                     100%                      ↑                      100% ← → 100%                      ↓                      100%                 </div>
	400				
	450				
	480				
	520				
	560				
600					

\*) Max. static load on the slow shaft: CSW: Conventional single wrap

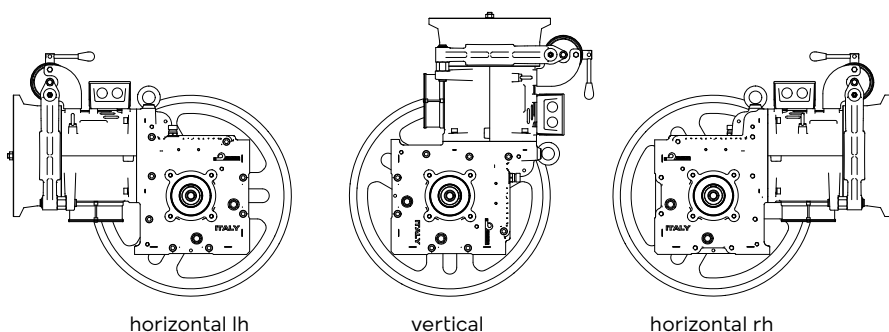

Brake Electromagnet		
[V]	[A]	[W]
24	5,25	126
48	2,30	110
60	1,77	106
80	1,50	120
110	1,02	112
200	0,63	126

		50Hz									60Hz								
		VVVF 1500 rpm 4 Poles AC2 1500/375 rpm 4/16 Poles									VVVF 1800 rpm 4 Poles AC2 1800/450 rpm 4/16 Poles								
		Motor Output [kW]																	
		VVVF AC2 4	VVVF AC2 5,5	AC2 6,8	VVVF 7,5	AC2 7,5	AC2 9	VVVF 9,2	VVVF 11		VVVF AC2 4,4	VVVF AC2 6	AC2 7,4	VVVF 8,2	AC2 8,2	VVVF AC2 10	VVVF 12		
R.R.	Traction Sheave Ø	Speed syn.	Max Rated Load								Speed syn.	Max Rated Load							
[i]	[mm]	[m/s]	[kg]	[kg]	[kg]	[kg]	[kg]	[kg]	[kg]	[kg]	[m/s]	[kg]	[kg]	[kg]	[kg]	[kg]	[kg]		
1/71	360	0,40	950	--	--	--	--	--	--	0,48	950	--	--	--	--	--	--		
1/71	400	0,44	855	--	--	--	--	--	--	0,53	855	--	--	--	--	--	--		
1/59	360	0,48	925	950	--	--	--	--	--	0,58	840	950	--	--	--	--	--		
1/71	450	0,50	760	--	--	--	--	--	--	0,60	760	--	--	--	--	--	--		
1/71	480	0,53	710	--	--	--	--	--	--	0,64	710	--	--	--	--	--	--		
1/59	400	0,53	835	950	--	--	--	--	--	0,64	755	935	--	--	--	--	--		
1/52	360	0,54	835	950	--	--	--	--	--	0,65	755	950	--	--	--	--	--		
1/71	520	0,58	655	--	--	--	--	--	--	0,69	655	--	--	--	--	--	--		
1/59	450	0,60	740	910	--	--	--	--	--	0,72	670	830	--	--	--	--	--		
1/52	400	0,60	750	950	--	--	--	--	--	0,72	680	950	--	--	--	--	--		
1/71	560	0,62	610	--	--	--	--	--	--	0,74	610	--	--	--	--	--	--		
1/45	360	0,63	735	950	--	--	--	--	--	0,75	665	945	950	950	--	--	--		
1/59	480	0,64	695	855	--	--	--	--	--	0,77	630	780	--	--	--	--	--		
1/71	600	0,66	570	--	--	--	--	--	--	0,80	570	--	--	--	--	--	--		
1/52	450	0,68	665	950	--	--	--	--	--	0,82	605	860	905	905	--	--	--		
1/59	520	0,69	640	790	--	--	--	--	--	0,83	580	720	--	--	--	--	--		
1/45	400	0,70	660	945	950	950	--	--	--	0,84	595	850	950	950	--	--	--		
1/52	480	0,72	625	890	920	920	--	--	--	0,87	565	805	845	845	--	--	--		
1/59	560	0,75	595	730	--	--	--	--	--	0,89	540	665	--	--	--	--	--		
1/37	360	0,76	625	890	950	950	--	--	--	0,92	565	805	950	950	--	--	--		
1/45	450	0,79	585	840	950	950	--	--	--	0,94	530	755	950	950	--	--	--		
1/52	520	0,79	575	825	850	850	--	--	--	0,94	525	745	780	780	--	--	--		
2/71	360	0,80	605	860	950	950	--	--	--	0,96	545	775	950	950	--	--	--		
1/59	600	0,80	555	685	--	--	--	--	--	0,96	505	625	--	--	--	--	--		
1/45	480	0,84	550	785	950	950	--	--	--	1,01	495	710	895	915	915	--	--		
1/52	560	0,85	535	765	790	790	--	--	--	1,01	485	690	725	725	--	--	--		
1/37	400	0,85	565	800	935	935	--	--	--	1,02	510	720	895	895	--	--	--		
2/71	400	0,88	545	775	855	855	--	--	--	1,06	490	695	855	855	--	--	--		
1/52	600	0,91	500	715	735	735	--	--	--	1,09	455	645	675	675	--	--	--		
1/45	520	0,91	505	725	890	890	--	--	--	1,09	460	655	825	845	845	--	--		
1/37	450	0,96	500	715	830	830	--	--	--	1,15	450	640	795	795	--	--	--		
1/45	560	0,98	470	675	825	825	--	--	--	1,17	425	605	765	785	785	--	--		
2/71	450	1,00	485	690	760	760	--	--	--	1,19	435	620	760	760	--	--	--		
1/37	480	1,02	470	670	780	780	--	--	--	1,22	425	600	745	745	--	--	--		
1/45	600	1,05	440	630	770	770	--	--	--	1,26	395	565	715	730	730	--	--		
2/71	480	1,06	455	645	710	710	--	--	--	1,27	410	580	710	710	--	--	--		
2/53	360	1,07	465	660	830	925	925	950	950	1,28	420	595	750	835	835	950	--		

CONTINUED ON NEXT PAGE →

		50Hz									60Hz								
		VVVF 1500 rpm 4 Poles AC2 1500/375 rpm 4/16 Poles									VVVF 1800 rpm 4 Poles AC2 1800/450 rpm 4/16 Poles								
		Motor Output [kW]																	
		VVVF AC2 4	VVVF AC2 5,5	AC2 6,8	VVVF 7,5	AC2 7,5	AC2 9	VVVF 9,2	VVVF 11		VVVF AC2 4,4	VVVF AC2 6	AC2 7,4	VVVF 8,2	AC2 8,2	VVVF AC2 10	VVVF 12		
R.R.	Traction Sheave Ø	Speed syn.	Max Rated Load								Speed syn.	Max Rated Load							
[i]	[mm]	[m/s]	[kg]	[kg]	[kg]	[kg]	[kg]	[kg]	[kg]	[kg]	[m/s]	[kg]	[kg]	[kg]	[kg]	[kg]	[kg]		
1/37	520	1,10	430	615	720	720	--	--	--	--	1,32	390	555	690	690	--	--	--	
2/71	520	1,15	420	595	655	655	--	--	--	--	1,38	380	535	655	655	--	--	--	
2/53	400	1,19	415	595	750	830	830	950	950	--	1,42	375	535	675	755	755	930	935	
1/37	560	1,19	400	570	665	665	--	--	--	--	1,43	365	515	640	640	--	--	--	
2/71	560	1,24	390	550	610	610	--	--	--	--	1,49	350	495	610	610	--	--	--	
1/37	600	1,27	375	535	625	625	--	--	--	--	1,53	340	480	595	595	--	--	--	
2/71	600	1,33	360	515	570	570	--	--	--	--	1,59	325	465	570	570	--	--	--	
2/53	450	1,33	370	530	665	740	740	895	910	--	1,60	335	475	600	670	670	825	830	
2/53	480	1,42	345	495	625	690	690	840	855	--	1,71	315	445	560	625	625	775	780	
2/53	520	1,54	320	455	575	640	640	775	790	--	1,85	290	410	520	580	580	715	720	
2/53	560	1,66	295	425	535	595	595	720	730	--	1,99	270	380	480	535	535	665	--	
2/53	600	1,78	275	395	500	555	555	670	685	--	2,13	250	355	450	500	500	620	625	
3/47	360	1,80	280	405	510	565	565	685	700	850	2,17	255	365	460	510	510	635	770	
3/47	400	2,01	255	365	455	510	510	615	630	765	2,41	230	325	410	460	460	570	690	
3/47	450	2,26	225	320	405	450	450	550	560	680	2,71	205	290	365	410	410	505	615	
3/47	480	2,41	210	300	380	425	425	515	525	635	2,89	190	270	345	385	385	475	575	
3/47	520	2,61	195	280	350	390	390	475	485	585	3,13	175	250	315	355	355	435	530	
3/47	560	2,81	180	260	325	360	360	440	450	545	3,37	165	235	295	330	330	405	495	
3/47	600	3,01	170	240	305	340	340	410	420	510	3,61	155	215	275	305	305	380	460	

		50Hz									60Hz								
		Motor Output [kW]									Motor Output [kW]								
		VVVF AC2 4	VVVF AC2 5,5	AC2 6,8	VVVF 7,5	AC2 7,5	AC2 9	VVVF 9,2	VVVF 11		VVVF AC2 4,4	VVVF AC2 6	AC2 7,4	VVVF 8,2	AC2 8,2	VVVF AC2 10	VVVF 12		
R.R.	Max Output Torque	Geared Efficiency								Max Output Torque	Geared Efficiency								
[i]	[Nm]									[Nm]									
1/71	1050	0,69	0,72	0,73	0,73	0,73	0,74	0,74	0,75	1050	0,68	0,71	0,72	0,73	0,73	0,74	0,74		
1/59	1260	0,72	0,74	0,76	0,76	0,76	0,77	0,77	0,78	1150	0,71	0,74	0,75	0,76	0,76	0,77	0,77		
1/52	1360	0,73	0,76	0,77	0,78	0,78	0,79	0,79	0,80	1250	0,72	0,75	0,77	0,78	0,78	0,79	0,79		
1/45	1420	0,74	0,77	0,79	0,79	0,79	0,80	0,81	0,81	1350	0,74	0,77	0,78	0,79	0,79	0,80	0,81		
1/37	1150	0,77	0,80	0,81	0,82	0,82	0,83	0,83	0,84	1100	0,76	0,79	0,81	0,81	0,81	0,82	0,83		
2/71	1050	0,78	0,80	0,82	0,82	0,82	0,83	0,83	0,84	1050	0,77	0,80	0,81	0,82	0,82	0,83	0,83		
2/53	1260	0,80	0,83	0,84	0,85	0,85	0,86	0,86	0,87	1150	0,79	0,82	0,84	0,84	0,84	0,86	0,86		
3/47	1240	0,83	0,86	0,87	0,88	0,88	0,89	0,89	0,90	1140	0,82	0,85	0,87	0,87	0,87	0,89	0,89		

Rated load values listed in the table include the weight of the ropes.

To know the theoretical load, subtract the weight of the ropes.

Position Of The Geared = Top Counterweight = 50% Plant efficiency = 0,80

		50Hz						60Hz					
		VVVF 1000 rpm 6 Poles AC2 1000/375 rpm 6/16 Poles						VVVF 1200 rpm 6 Poles AC2 1200/450 rpm 6/16 Poles					
		Motor Output [kW]											
		VVVF/AC2 2,7	VVVF/AC2 3,6	VVVF 4,2	AC2 4,5	VVVF 5							
R.R.	Traction Sheave Ø	Speed syn.	Max Rated Load					Speed syn.	Max Rated Load				
[i]	[mm]	[m/s]	[kg]	[kg]	[kg]	[kg]	[kg]	[m/s]	[kg]	[kg]	[kg]	[kg]	
1/71	360	0,27	950	--	--	--	--	0,32	950	--	--	--	
1/71	400	0,29	855	--	--	--	--	0,35	855	--	--	--	
1/59	360	0,32	945	950	--	--	--	0,38	950	--	--	--	
1/71	450	0,33	760	--	--	--	--	0,40	760	--	--	--	
1/71	480	0,35	710	--	--	--	--	0,42	710	--	--	--	
1/59	400	0,35	850	950	--	--	--	0,43	950	--	--	--	
1/52	360	0,36	850	950	--	--	--	0,43	950	--	--	--	
1/71	520	0,38	655	--	--	--	--	0,46	655	--	--	--	
1/59	450	0,40	755	910	--	--	--	0,48	910	--	--	--	
1/52	400	0,40	765	950	--	--	--	0,48	950	--	--	--	
1/71	560	0,41	610	--	--	--	--	0,50	610	--	--	--	
1/45	360	0,42	750	950	--	--	--	0,50	945	950	950	--	
1/59	480	0,43	705	855	--	--	--	0,51	855	--	--	--	
1/71	600	0,44	570	--	--	--	--	0,53	570	--	--	--	
1/52	450	0,45	680	935	950	950	--	0,54	860	950	950	--	
1/59	520	0,46	650	790	--	--	--	0,55	790	--	--	--	
1/45	400	0,47	675	930	950	950	--	0,56	850	950	950	--	
1/52	480	0,48	635	875	920	920	--	0,58	805	920	920	--	
1/59	560	0,50	605	730	--	--	--	0,60	730	--	--	--	
1/37	360	0,51	640	875	950	950	--	0,61	805	950	950	--	
1/45	450	0,52	600	825	950	950	--	0,63	755	905	945	950	
1/52	520	0,52	590	810	850	850	--	0,63	745	850	850	--	
2/71	360	0,53	615	845	950	950	--	0,64	775	925	950	950	
1/59	600	0,53	565	685	--	--	--	0,64	685	--	--	--	
1/45	480	0,56	560	775	915	950	950	0,67	710	850	885	950	
1/52	560	0,56	545	750	790	790	--	0,68	690	790	790	--	
1/37	400	0,57	575	790	935	935	--	0,68	725	865	905	935	
2/71	400	0,59	555	760	855	855	--	0,71	700	835	855	855	
1/52	600	0,60	510	700	735	735	--	0,72	645	735	735	--	
1/45	520	0,61	515	715	845	890	890	0,73	655	780	820	890	
1/37	450	0,64	510	700	830	830	--	0,76	645	770	805	830	
1/45	560	0,65	480	665	785	825	825	0,78	610	725	760	825	
2/71	450	0,66	495	675	760	760	--	0,80	620	740	760	760	
1/37	480	0,68	480	655	775	780	780	0,82	605	720	755	780	
1/45	600	0,70	450	620	730	770	770	0,84	565	680	710	770	
2/71	480	0,71	460	635	710	710	--	0,85	580	695	710	710	
2/53	360	0,71	470	650	770	825	925	0,85	595	710	745	845	

CONTINUED ON NEXT PAGE →

		50Hz					60Hz					
		VVVF 1000 rpm 6 Poles AC2 1000/375 rpm 6/16 Poles					VVVF 1200 rpm 6 Poles AC2 1200/450 rpm 6/16 Poles					
		Motor Output [kW]										
		VVVF/AC2 2,7	VVVF/AC2 3,6	VVVF 4,2	AC2 4,5	VVVF 5		VVVF/AC2 4	VVVF 4,7	AC2 4,9	VVVF 5,5	
R.R.	Traction Sheave Ø	Speed syn.	Max Rated Load					Speed syn.	Max Rated Load			
[i]	[mm]	[m/s]	[kg]	[kg]	[kg]	[kg]	[kg]	[m/s]	[kg]	[kg]	[kg]	[kg]
1/37	520	0,74	440	605	715	720	720	0,88	555	665	695	720
2/71	520	0,77	425	585	655	655	--	0,92	535	640	655	655
2/53	400	0,79	425	585	690	745	835	0,95	535	640	670	760
1/37	560	0,79	410	565	665	665	--	0,95	515	615	645	665
2/71	560	0,83	395	545	610	610	--	0,99	500	595	610	610
1/37	600	0,85	380	525	620	625	625	1,02	480	575	600	625
2/71	600	0,88	370	505	570	570	--	1,06	465	555	570	570
2/53	450	0,89	375	520	615	660	740	1,07	475	570	595	675
2/53	480	0,95	355	485	575	620	695	1,14	445	535	555	630
2/53	520	1,03	325	450	530	570	640	1,23	410	490	515	585
2/53	560	1,11	305	415	495	530	595	1,33	380	455	475	540
2/53	600	1,19	280	390	460	495	555	1,42	355	425	445	505
3/47	360	1,20	290	395	470	505	565	1,44	365	435	455	515
3/47	400	1,34	260	355	425	455	510	1,60	330	390	410	465
3/47	450	1,50	230	315	375	405	455	1,80	290	345	365	410
3/47	480	1,60	215	295	350	380	425	1,93	275	325	340	385
3/47	520	1,74	200	275	325	350	390	2,09	250	300	315	355
3/47	560	1,87	185	255	300	325	365	2,25	235	280	290	330
3/47	600	2,01	170	235	280	305	340	2,41	220	260	270	310

		50Hz					60Hz				
		Motor Output [kW]					Motor Output [kW]				
		VVVF/AC2 2,7	VVVF/AC2 3,6	VVVF 4,2	AC2 4,5	VVVF 5		VVVF/AC2 4	VVVF 4,7	AC2 4,9	VVVF 5,5
R.R.	Max Output Torque	Geared Efficiency					Max Output Torque	Geared Efficiency			
[i]	[Nm]						[Nm]				
1/71	1050	0,70	0,72	0,73	0,73	0,73	1050	0,71	0,72	0,72	0,73
1/59	1260	0,72	0,74	0,75	0,76	0,76	1260	0,74	0,75	0,75	0,76
1/52	1360	0,74	0,76	0,77	0,77	0,78	1360	0,75	0,77	0,77	0,78
1/45	1420	0,75	0,78	0,79	0,79	0,80	1420	0,77	0,78	0,78	0,79
1/37	1150	0,78	0,80	0,81	0,82	0,82	1150	0,79	0,81	0,81	0,82
2/71	1050	0,78	0,81	0,82	0,82	0,82	1050	0,80	0,81	0,81	0,82
2/53	1260	0,80	0,83	0,84	0,84	0,85	1260	0,82	0,83	0,84	0,84
3/47	1240	0,83	0,86	0,87	0,88	0,88	1240	0,85	0,87	0,87	0,88

Rated load values listed in the table include the weight of the ropes.

To know the theoretical load, subtract the weight of the ropes.

Position Of The Geared = Top Counterweight = 50% Plant efficiency = 0,80

50Hz										
VVVF 1500 rpm 4 Poles AC2 1500/375 rpm 4/16 Poles										
Asynchronous Rated Power [kW]										
	VVVF 4	VVVF 5,5	VVVF 7,5	VVVF 9,2	VVVF 11	AC2 4	AC2 5,5	AC2 6,8	AC2 7,5	AC2 9
Motor Parameters										
Rated Voltage (star connection) <sup>(1) (3)</sup>	[V]	400	400	400	400	400	400	400	400	400
Frequency	[Hz]	50	50	50	50	50	50	50	50	50
Synchronous Speed	[rpm]	1500	1500	1500	1500	1500	1500/375	1500/375	1500/375	1500/375
Asynchronous Speed	[rpm]	1423	1424	1450	1458	1457	1359/276	1359/280	1325/267	1350/297
Rated Current <sup>(2)</sup>	[A]	9,4	12,4	17,8	22,5	24,1	11,3/11,1	15/15,5	16,5/10,8	18,3/14,9
Rated Torque	[Nm]	26,8	36,9	49,4	60	72	28,1	38,7	49	53
Cos $\phi$ Power Factor	[ ]	0,76	0,78	0,72	0,70	0,76	0,64	0,69	0,8	0,78
Starting Current	[A]	41	51	95	130	157	39	52	65	65
Starting Torque	[Nm]	54	78	120	158	163	79	94	114	134
Duty Cycle	[%]	60	60	60	60	60	30+10	30+10	30+10	30+10
Starts per Hour	[s/h]	240	240	240	240	240	180	180	180	180
Insulation Class	[ ]	F	F	F	F	F	F	F	F	F
Degree of Protection IP	[ ]	IP21	IP21	IP21	IP21	IP21	IP21	IP21	IP21	IP21

(1) The motors are standard supplied with star connection ( Y ), the customer can arrange a delta connection (  $\Delta$  ).

(2) The indicated current values are related to 400V voltage. For current values with delta connection, multiply the values by 1,732.

(3) The standard supply voltage is suitable for 380-400V/220-230V power supplies.

The geared machine includes a fan, 1~220...240V, 50/60Hz.

Available on request 115V supply voltage.

50Hz							
VVVF 1000 rpm 6 Poles AC2 1000/375 rpm 6/16 Poles							
Asynchronous Rated Power [kW]							
	VVVF 2,7	VVVF 3,6	VVVF 4,2	VVVF 5	AC2 2,7	AC2 3,6	AC2 4,5
Motor Parameters							
Rated Voltage (star connection) <sup>(1) (3)</sup>	[V]	400	400	400	400	400	400
Frequency	[Hz]	50	50	50	50	50	50
Synchronous Speed	[rpm]	1000	1000	1000	1000	1000/375	1000/375
Asynchronous Speed	[rpm]	955	962	947	957	893/268	917/270
Rated Current <sup>(2)</sup>	[A]	8,4	10,9	14,1	15,2	10,9/11,5	15/12,4
Rated Torque	[Nm]	27	35,7	41,2	50	28,9	37,2
Cos $\phi$ Power Factor	[ ]	0,61	0,62	0,54	0,65	0,52	0,50
Starting Current	[A]	30	43	63	72	29	39
Starting Torque	[Nm]	46	80	100	105	69	98
Duty Cycle	[%]	60	60	60	60	30+10	30+10
Starts per Hour	[s/h]	240	240	240	240	180	180
Insulation Class	[ ]	F	F	F	F	F	F
Degree of Protection IP	[ ]	IP21	IP21	IP21	IP21	IP21	IP21

(1) The motors are standard supplied with star connection ( Y ), the customer can arrange a delta connection (  $\Delta$  ).

(2) The indicated current values are related to 400V voltage. For current values with delta connection, multiply the values by 1,732.

(3) The standard supply voltage is suitable for 380-400V/220-230V power supplies.

The geared machine includes a fan, 1~220...240V, 50/60Hz.

Available on request 115V supply voltage.

## 60Hz

**VVVF 1800 rpm 4 Poles**  
**AC2 1800/450 rpm 4/16 Poles**

Asynchronous Rated Power [kW]

VVVF 4,4	VVVF 6	VVVF 8,2	VVVF 10	VVVF 12	AC2 4,4	AC2 6	AC2 7,4	AC2 8,2	AC2 10
Motor Parameters									
400	400	400	400	400	400	400	400	400	400
60	60	60	60	60	60	60	60	60	60
1800	1800	1800	1800	1800	1800/450	1800/450	1800/450	1800/450	1800/450
1714	1708	1741	1751	1748	1606/330	1680/380	1665/345	1670/362	1664/373
10,2	15,2	19	22,5	25,5	11,8/10	18/14	16,5/11,5	19,2/15	22/18,4
24,5	33,5	45	54,5	65	26,2	34,1	42	47	56,8
0,75	0,70	0,72	0,72	0,76	0,63	0,78	0,79	0,76	0,80
48	70	88	117	141	39	46	52	60	61
44	70	101	160	171	64	73	85	110	147
60	60	60	60	60	30+10	30+10	30+10	30+10	30+10
240	240	240	240	240	180	180	180	180	180
F	F	F	F	F	F	F	F	F	F
IP21	IP21	IP21	IP21	IP21	IP21	IP21	IP21	IP21	IP21

## 60Hz

**VVVF 1200 rpm 6 Poles**  
**AC2 1200/450 rpm 6/16 Poles**

Asynchronous Rated Power [kW]

VVVF 4	VVVF 4,7	VVVF 5,5	AC2 4	AC2 4,9
Motor Parameters				
400	400	400	400	400
60	60	60	60	60
1200	1200	1200	1200/450	1200/450
1138	1160	1148	1096/318	1106/411
12,4	15,4	15	18,7/14,3	15,3/13,2
33,6	38,7	46	34,8	42,3
0,60	0,55	0,70	0,58	0,70
49	67	138	--	--
62	74	154	--	--
60	60	60	30+10	30+10
240	240	240	180	180
F	F	F	F	F
IP21	IP21	IP21	IP21	IP21



Wrapping System	Traction sheave		Max n° Grooves x D	Grooves Pitch
	D [mm]	E [mm]	n° x mm	l [mm]
CSW	360	100	6xD8	14
	360	100	5xD9 (6xD9)	17 (16)
	400	100	6xD8	14
	400	100	5xD9 (6xD9)	17 (16)
	400	100	5xD10 (6xD10)	17 (16)
	450	100	6xD8	14
	450	100	5xD9 (6xD9)	17 (16)
	450	100	5xD10 (6xD10)	17 (16)
	450	100	5xD11 (6xD11)	17 (16)
	480	100	6xD8	14
	480	100	5xD9 (6xD9)	17 (16)
	480	100	5xD10 (6xD10)	17 (16)
	480	100	5xD11 (6xD11)	17 (16)
	480	100	4xD12	19
	520	100	6xD8	14
	520	100	5xD9 (6xD9)	17 (16)
	520	100	5xD10 (6xD10)	17 (16)
	520	100	5xD11 (6xD11)	17 (16)
	520	100	4xD12	19
	520	100	4xD13	19
	560	100	6xD8	14
	560	100	5xD9 (6xD9)	17 (16)
	560	100	5xD10 (6xD10)	17 (16)
	560	100	5xD11 (6xD11)	17 (16)
	560	100	4xD12	19
	560	100	4xD13	19
	600	100	6xD8	14
	600	100	5xD9 (6xD9)	17 (16)
	600	100	5xD10 (6xD10)	17 (16)
	600	100	5xD11 (6xD11)	17 (16)
600	100	4xD12	19	
600	100	4xD13	19	

## VCI

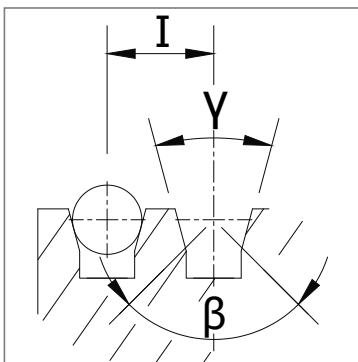

V grooves with undercut

## UCI

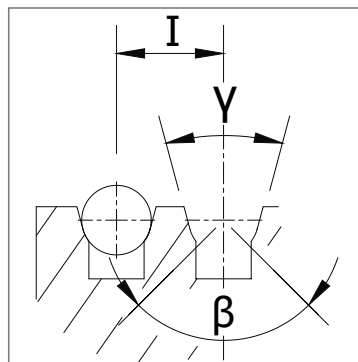

U grooves with undercut

$\gamma$  = groove angle  
 $\beta$  = undercut angle  
 $I$  = grooves pitch

## BEDPLATE | TOP MACHINE WITHOUT DIVERTING PULLEY FOR CSW WINDING

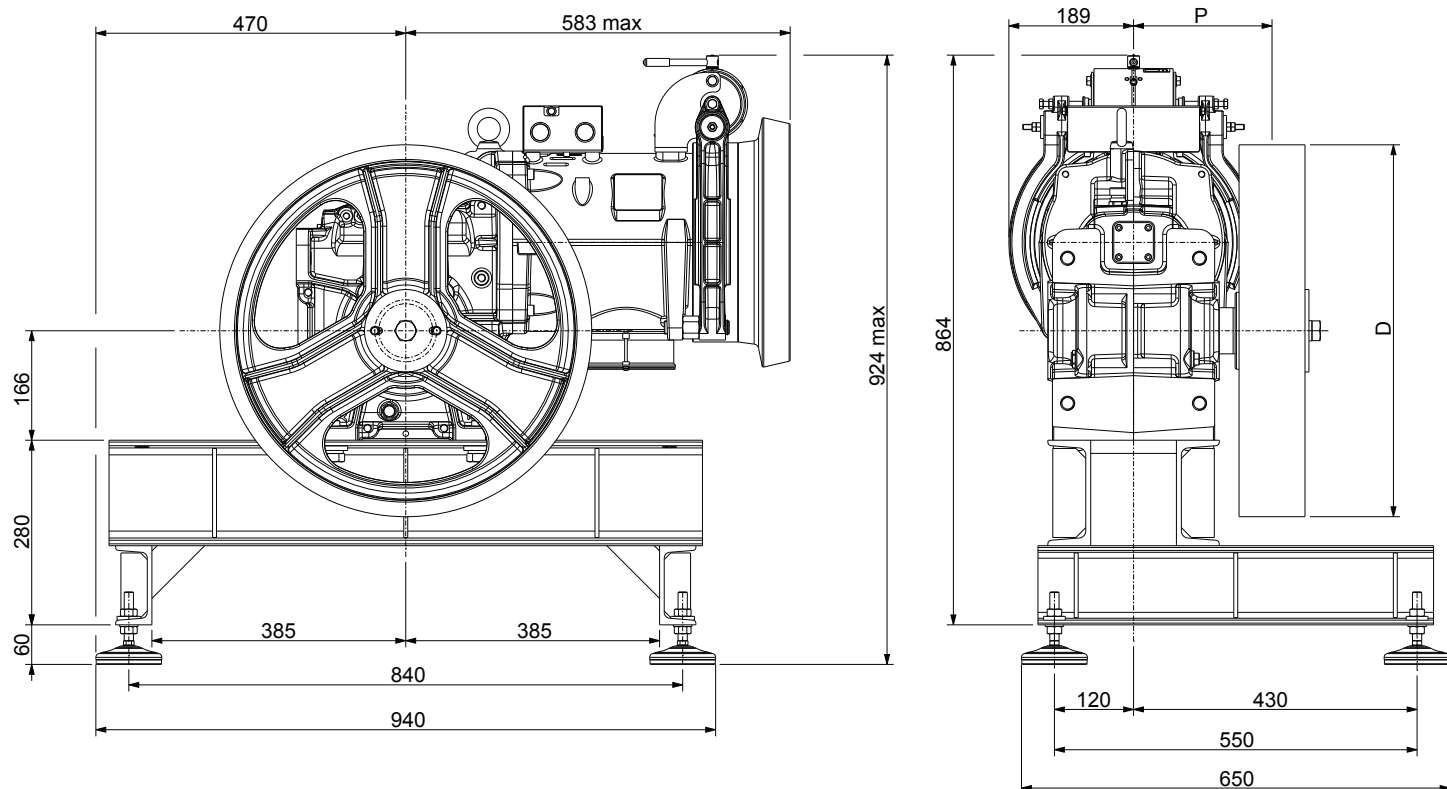

XTE0339 (included vibration dampers)

Weight of machine bedplate: 67 kg (bedplate + vibration dampers)

## VIBRATIONS DAMPER SET UP

Damper code	Dimension
	[mm]
TAI0110	D.100x28

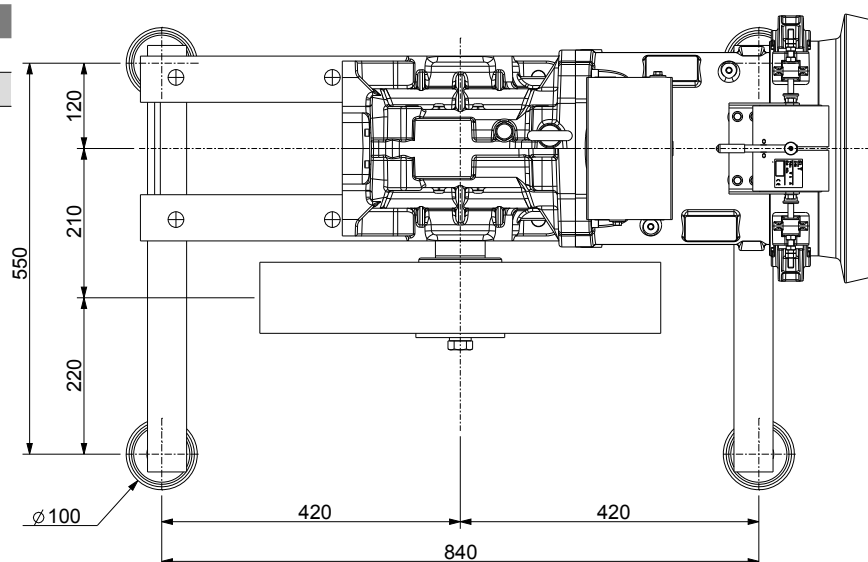

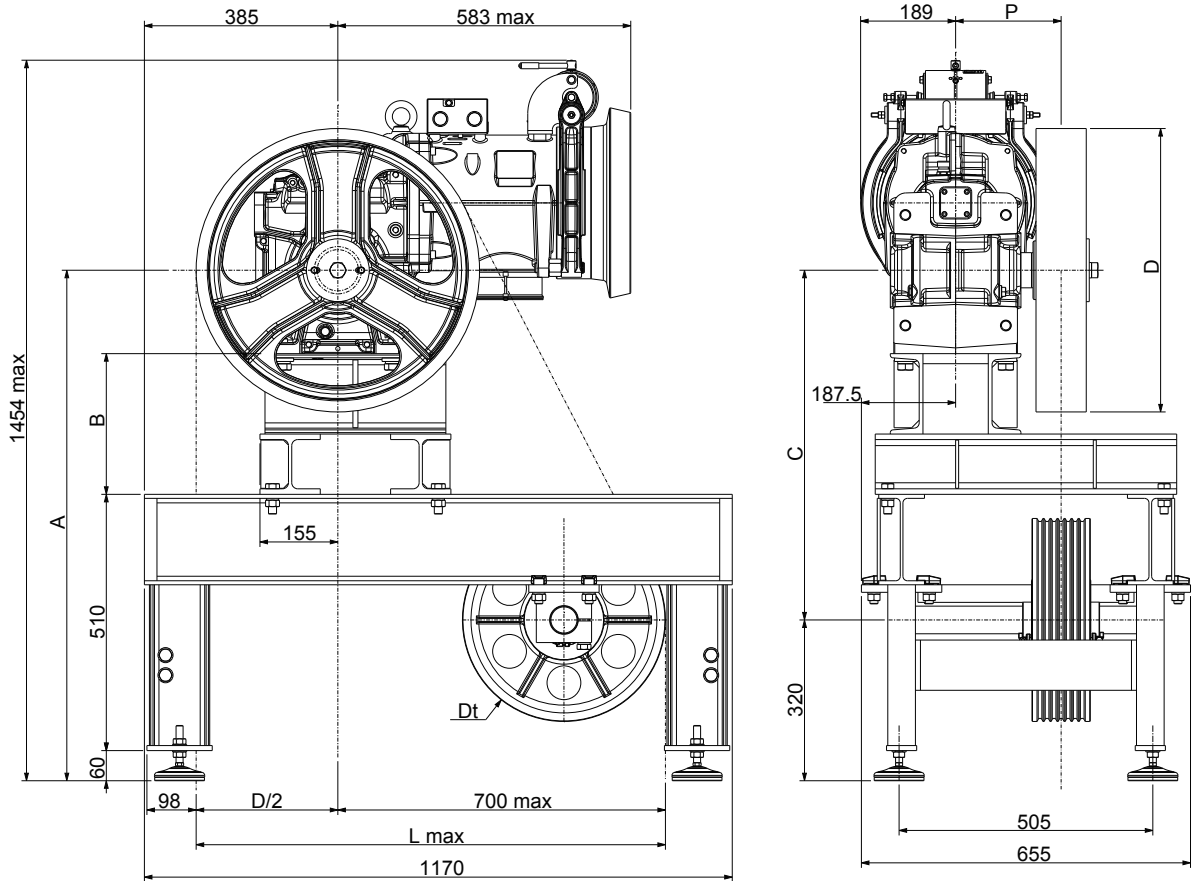

Traction Sheave	X	L Max
D [mm]	[mm]	[mm]
360	200	880
400	180	900
450	155	925
480	140	940
520	120	960
560	105	975
600	80	1000

Diverting Pulley	A	B	C
Dt [mm]	[mm]	[mm]	[mm]
400	1016	280	696
450	1016	280	696
520	1036	300	716

XTE6026 (Dt 400-450) - XTE6027 (Dt 520)

Weight of machine bedplate: (XTE6026) 159 Kg, (XTE6027) 176 Kg (bedplate + diverting pulley + vibration dampers)

VIBRATIONS DAMPER SET UP

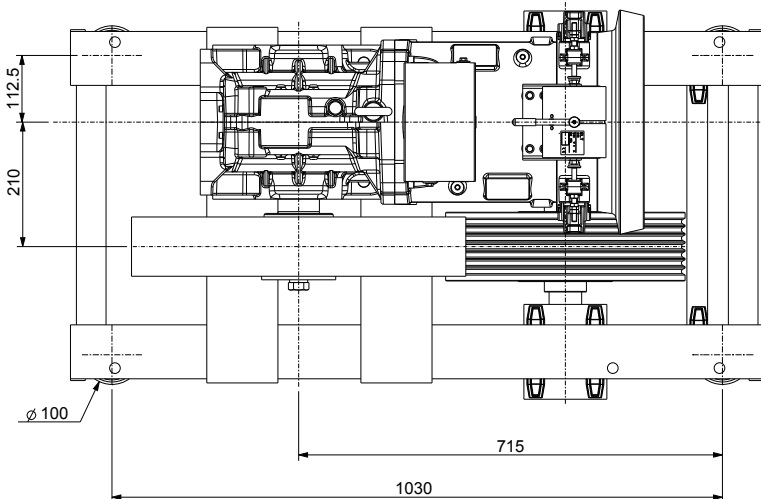

Damper code	Dimension
	[mm]
TAI0110	D.100x28

**BEDPLATE SH140 LS | BOTTOM DRIVE MACHINE WITH CSW WRAPPING**

(Ropes upwards)

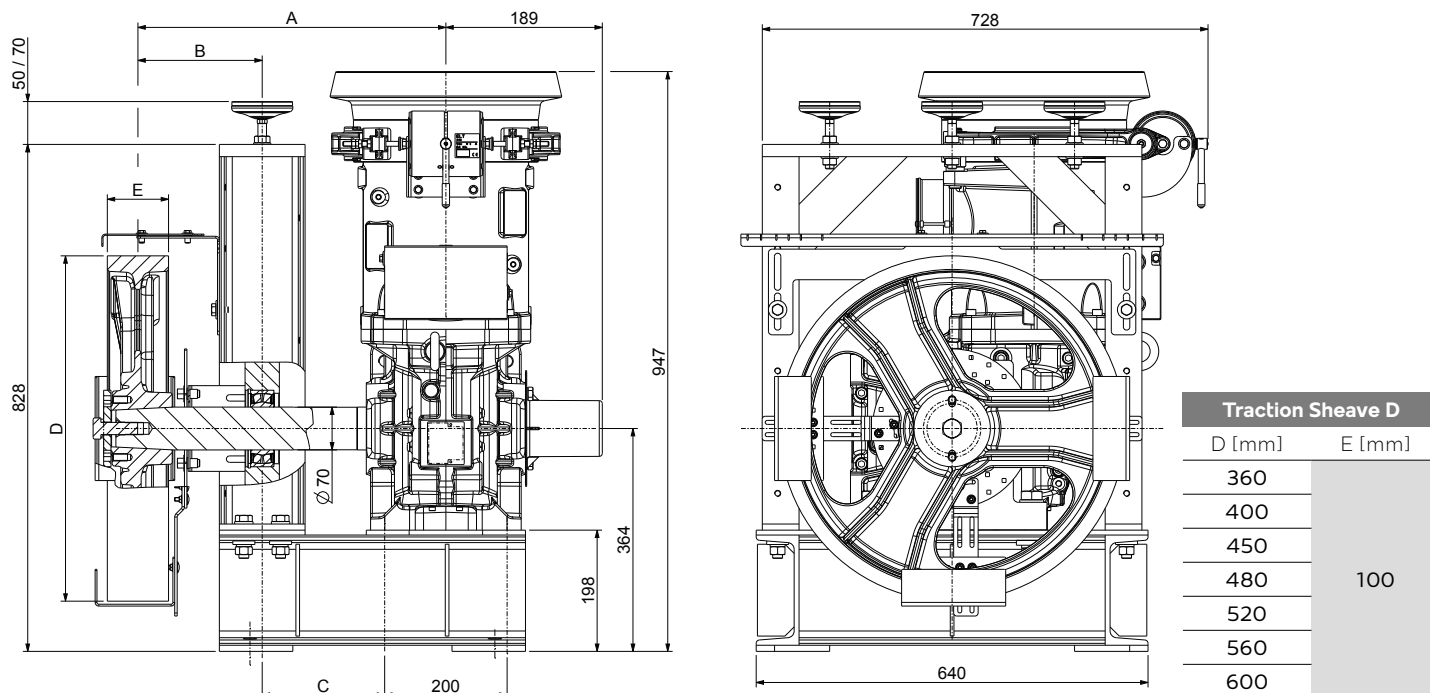

Quote "A"	Quote "B"	Quote "C"	Static load	Code*
[mm]	[mm]	[mm]	[kg]	
500	150	250	2000	XTE3727
	175	225	1700	XTE3728
	200	200	1500	XTE3729
600	150	350	2000	XTE3724
	175	325	1700	XTE3725
	200	300	1500	XTE3726
725	150	475	2000	XTE3721
	175	450	1700	XTE3722
	200	425	1500	XTE3723

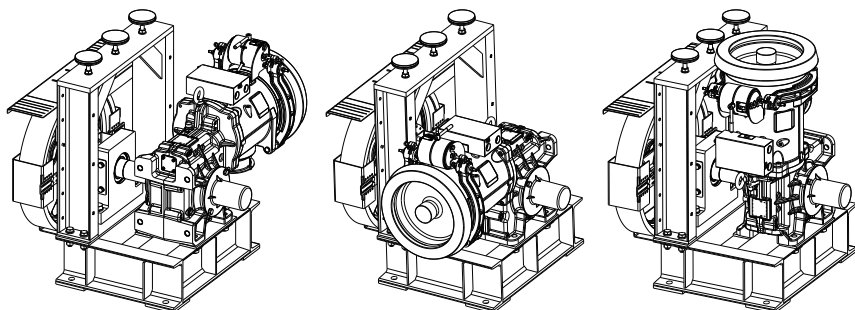
**INSTALLATION POSITION**

Right hand Machine

Left hand Machine

Vertical Machine

\*Always supplied with the machine.

**DIVERTING PULLEYS AND GROOVES NUMBER x ROPES DIAMETER**

Diverting Pulley		Max n° Grooves x D	Grooves Pitch
Dt [mm]	E [mm]	n° x mm	l [mm]
400	116	7xD8	14
450	116	6xD11	17
520	116	5xD13	19

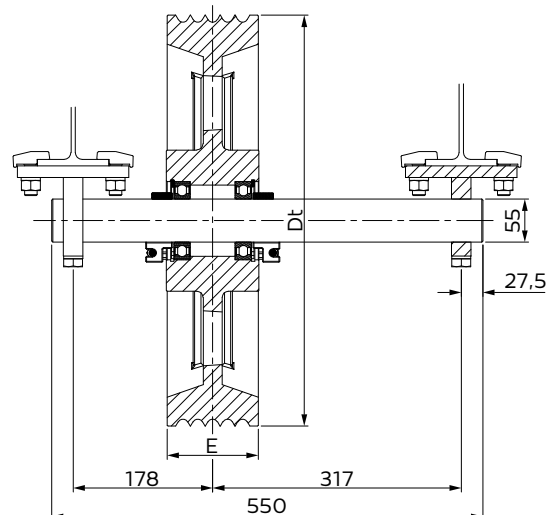
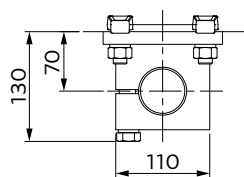



by  
**SICOR ITALY**  
AN  ELEVANTIS COMPANY

**Sicor Italy S.R.L.**

Viale Caproni, 32 Rovereto (TN) - Italy · Tel: +39 0464 484 111 · [info@sicoritaly.com](mailto:info@sicoritaly.com)

[www.sicoritaly.com](http://www.sicoritaly.com)