

SH140T

GEARED MACHINES SH SERIES



Model	For rated loads up to	Speed range synchronous		Traction sheaves diameter	Max Static Load		
		50Hz [m/s]	60Hz [m/s]				
SH140T 	[kg]	225	0,60	--	400	[kN-kg]	--

Roping 1 : 1



SH140T



Geared machine Lh

Power Range 50 Hz 4 poles VVVF **5,5 kW**

Ratio **1/52**

Speed synchronous **0,60 m/s**

Geared Weight **350 kg**

Oil capacity **3,6 l**

Geared machine Rh o Lh (from motor side) **Image ref. to Lh geared**

DIMENSIONS

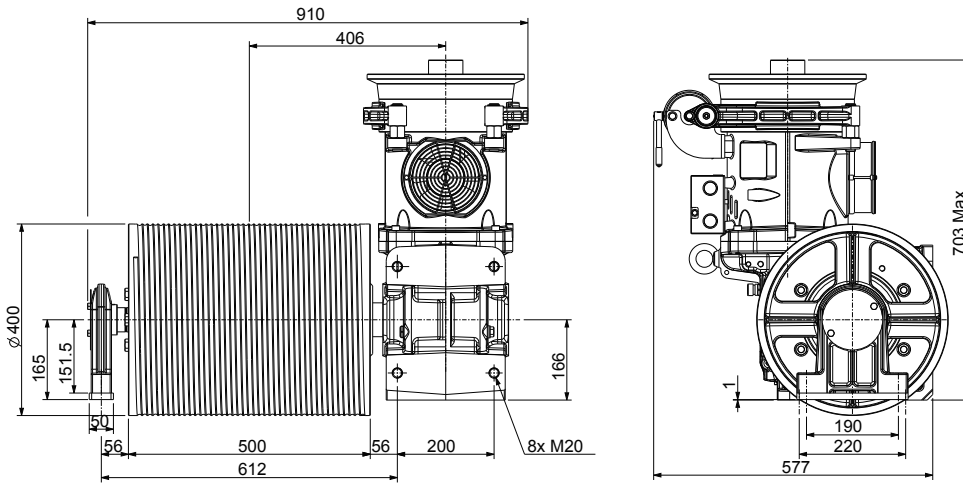

Brake Electromagnet		
[V]	[A]	[W]
24	5,25	126
48	2,30	110
60	1,77	106
80	1,50	120
110	1,02	112
200	0,63	126

DUTY TABLE

Roping 1:1

50Hz
VVVF 1500 rpm 4 Poles
Motor Output [kW]
VVVF 5,5

R.R.	Traction Drum Ø	Installation frequency	Max Rated Load	Max cabin load	Ropes Nr x diameter Ø	Max travel with 2 parallel ropes
[i]	[mm]	[Hz]	[kg]	[kg]	[mm]	[m]
1/52	400	50	225	300	2 x Ø8	29
					2 x Ø9	26
					2 x Ø10	23

Rated load values listed in the table include the weight of the ropes. To know the theoretical load, subtract the weight of the ropes.

Position Of The Geared = Top Plant efficiency = 0,85

ELECTRIC MOTOR DATA

50Hz		
VVVF 1500 rpm 4 Poles		
Asynchronous Rated Power [kW]		
VVVF 5,5		
Motor Parameters		
Rated Voltage (star connection) ⁽¹⁾⁽³⁾	[V]	400
Frequency	[Hz]	50
Synchronous Speed	[rpm]	1500
Asynchronous Speed	[rpm]	1424
Rated Current (2)	[A]	12,4
Rated Torque	[Nm]	36,9
Cos φ Power Factor	[]	0,78
Starting Current	[A]	51
Starting Torque	[Nm]	78
Duty Cycle	[%]	60
Starts per Hour	[s/h]	240
Insulation Class	[]	F
Degree of Protection IP	[]	IP21

(1) The motors are standard supplied with star connection (Y), the customer can arrange a delta connection (Δ).

(2) The indicated current values are related to 400V voltage. For current values with delta connection, multiply the values by 1,732.

(3) The standard supply voltage is suitable for 380-400V/220-230V power supplies.

The geared machine includes a fan, 1~220...240V, 50/60Hz.

Available on request 115V supply voltage.



by
SICOR ITALY
AN  ELEVANTIS COMPANY

Sicor Italy S.R.L.

Viale Caproni, 32 Rovereto (TN) - Italy · Tel: +39 0464 484 111 · info@sicoritaly.com

www.sicoritaly.com